INTERSTATE SERVICE GUIDE

Interstate Service Guide
for Customers of Detariffed Access Services
within the operating territories
listed on the Title Pages

LEGAL NOTICE

The FRONTIER Interstate Service Guide and Pricelist (Guide) applies to the FRONTIER "Detariffed Services" (as defined below) and other telecommunications services that are set forth in this Guide.

Detariffed Services, as described in this document, are interstate special access services for which tariffs were withdrawn pursuant to FCC Report and Order, FCC 17-43, released April 28, 2017.

Beginning upon the effectiveness of the withdrawal of Detariffed Service tariffs, Detariffed Services will be subject to and provided pursuant to the rates, terms and conditions of this Guide, unless a separately executed service agreement between you and Frontier provides otherwise.

Prospective customers wishing to purchase services at the rates, terms and conditions in the Guide may do so by initiating orders through the same processes used to order services from FRONTIER's interstate access tariffs.

Service that is ordered without a separately executed service agreement between you and FRONTIER that applies to that order, will also be subject to the FRONTIER Interstate Access Service Agreement at https://wholesale.frontier.com/dcaas-staticassets/wholesale/SourceFiles/ISG/FTR_Interstate_Access_Service_Agreement_06302023.pdf.

The services described in the Guide may be available through negotiated agreements, which may include rates, terms or conditions more favorable to you than those in the Guide. Prospective customers wishing to purchase Guide services at rates, terms or conditions different from those described in the Guide and the applicable FRONTIER Interstate Access Service Agreement may contact their FRONTIER service representative or go to the FRONTIER website at <https://wholesale.frontier.com/resources/pricing-guides/interstate-service-guide.html>.

FRONTIER reserves the right to change the rates, terms and conditions in the Guide from time to time. Notification of Guide changes will be made available at the FRONTIER website.

Disclaimer: This documentation is for information purposes only and does not obligate Frontier to provide services in the manner herein described. Frontier reserves the right as its sole option to modify or revise the information in this document at any time without prior notice. In no event shall Frontier or its agents, employees, directors, officers, representatives or suppliers be liable under contract, warranty, tort (including but not limited to negligence of Frontier), or any other legal theory, for any damages arising from or relating to this document or its contents, even if advised of the possibility of such damages.

ACCESS SERVICE

ISSUING CARRIERS

Frontier Telephone of Rochester, Inc.
in the State of New York
Vice President Government and Regulatory Affairs
VERIZON
ONE VERIZON WAY, MAIL CODE:180WVB (T)
BASKING RIDGE, NJ 07920 (T)

Frontier Communications of AuSable Valley, Inc. (AuSable)
in the State of New York
Vice President Government and Regulatory Affairs
VERIZON
ONE VERIZON WAY, MAIL CODE:180WVB (T)
BASKING RIDGE, NJ 07920 (T)

Frontier Communications of Breezewood, LLC (Breezewood)
in the State of Pennsylvania
Vice President Government and Regulatory Affairs
VERIZON
ONE VERIZON WAY, MAIL CODE:180WVB (T)
BASKING RIDGE, NJ 07920 (T)

Frontier Communications of Canton, LLC (Canton)
in the State of Pennsylvania
Vice President Government and Regulatory Affairs
VERIZON
ONE VERIZON WAY, MAIL CODE:180WVB (T)
BASKING RIDGE, NJ 07920 (T)

Frontier Communications of Michigan, Inc. (Michigan)
in the States of Michigan and Ohio
Vice President Government and Regulatory Affairs
VERIZON
ONE VERIZON WAY, MAIL CODE:180WVB (T)
BASKING RIDGE, NJ 07920 (T)

Frontier Communications of Pennsylvania, LLC (Pennsylvania)
in the State of Pennsylvania
Vice President Government and Regulatory Affairs
VERIZON
ONE VERIZON WAY, MAIL CODE:180WVB (T)
BASKING RIDGE, NJ 07920 (T)

ACCESS SERVICE

ISSUING CARRIERS (Cont'd)

Frontier Communications of Georgia, LLC
in the State of Georgia
(Frontier Communications of Fairmount Study Area) (OCN 0362)
Vice President Government and Regulatory Affairs
VERIZON
ONE VERIZON WAY, MAIL CODE:180WVB (T)
BASKING RIDGE, NJ 07920 (T)

Frontier Communications of New York, Inc. (New York)
in the State of New York
Vice President Government and Regulatory Affairs
VERIZON
ONE VERIZON WAY, MAIL CODE:180WVB (T)
BASKING RIDGE, NJ 07920 (T)

Frontier Communications of Illinois, Inc. (Illinois)
in the State of Illinois
Vice President Government and Regulatory Affairs
VERIZON
ONE VERIZON WAY, MAIL CODE:180WVB (T)
BASKING RIDGE, NJ 07920 (T)

Frontier Communications of Lakeside, Inc. (Lakeside)
In the State of Illinois
Vice President Government and Regulatory Affairs
VERIZON
ONE VERIZON WAY, MAIL CODE:180WVB (T)
BASKING RIDGE, NJ 07920 (T)

Frontier Communications of Lakewood, LLC (Lakewood)
in the State of Pennsylvania
Vice President Government and Regulatory Affairs
VERIZON
ONE VERIZON WAY, MAIL CODE:180WVB (T)
BASKING RIDGE, NJ 07920 (T)

Frontier Communications-Midland, Inc. (Midland)
in the State of Illinois
Vice President Government and Regulatory Affairs
VERIZON
ONE VERIZON WAY, MAIL CODE:180WVB (T)
BASKING RIDGE, NJ 07920 (T)

ACCESS SERVICE

ISSUING CARRIERS (Cont'd)

Frontier Communications of Wisconsin, LLC

in the State of Wisconsin
(Frontier Communications of Mondovi Study Area) (OCN 0912)
Vice President Government and Regulatory Affairs

VERIZON
ONE VERIZON WAY, MAIL CODE:180WVB (T)
BASKING RIDGE, NJ 07920 (T)

Frontier Communications of the South, LLC (Alabama)
in the State of Alabama
(Frontier Communications of Alabama Study Area) (OCN 0306)
Vice President Government and Regulatory Affairs

VERIZON
ONE VERIZON WAY, MAIL CODE:180WVB (T)
BASKING RIDGE, NJ 07920 (T)

Frontier Communications of Mt. Pulaski, Inc. (Mt. Pulaski)
in the State of Illinois
Vice President Government and Regulatory Affairs

VERIZON
ONE VERIZON WAY, MAIL CODE:180WVB (T)
BASKING RIDGE, NJ 07920 (T)

Frontier Communications of Orion, Inc. (Orion)
in the State of Illinois
Vice President Government and Regulatory Affairs

VERIZON
ONE VERIZON WAY, MAIL CODE:180WVB (T)
BASKING RIDGE, NJ 07920 (T)

Frontier Communications of Oswayo River, LLC (Oswayo)
in the State of Pennsylvania
Vice President Government and Regulatory Affairs

VERIZON
ONE VERIZON WAY, MAIL CODE:180WVB (T)
BASKING RIDGE, NJ 07920 (T)

Frontier Communications-Prairie, Inc. (Prairie)
in the State of Illinois
Vice President Government and Regulatory Affairs

VERIZON
ONE VERIZON WAY, MAIL CODE:180WVB (T)
BASKING RIDGE, NJ 07920 (T)

ACCESS SERVICE

ISSUING CARRIERS (Cont'd)

Frontier Communications-Schuyler, Inc. (Schuyler)
in the State of Illinois
Vice President Government and Regulatory Affairs
VERIZON
ONE VERIZON WAY, MAIL CODE:180WVB (T)
BASKING RIDGE, NJ 07920 (T)

Frontier Communications of Seneca Gorham, Inc. (Seneca Gorham)
in the State of New York
Vice President Government and Regulatory Affairs
VERIZON
ONE VERIZON WAY, MAIL CODE:180WVB (T)
BASKING RIDGE, NJ 07920 (T)

Frontier Communications of the South, LLC (South)
in the States of Alabama and Florida
(Frontier of the South Alabama Study Area) (OCN 4464)
(Frontier of the South Florida Study Area) (OCN 4465)
Vice President Government and Regulatory Affairs
VERIZON
ONE VERIZON WAY, MAIL CODE:180WVB (T)
BASKING RIDGE, NJ 07920 (T)

Frontier Communications of Sylvan Lake, Inc. (Sylvan)
in the State of New York
Vice President Government and Regulatory Affairs
VERIZON
ONE VERIZON WAY, MAIL CODE:180WVB (T)
BASKING RIDGE, NJ 07920 (T)

Frontier Communications of Thorntown, Inc. (Thorntown)
in the State of Indiana
Vice President Government and Regulatory Affairs
VERIZON
ONE VERIZON WAY, MAIL CODE:180WVB (T)
BASKING RIDGE, NJ 07920 (T)

Frontier Communications of Wisconsin, LLC (Wisconsin)
in the State of Wisconsin
(Frontier Communications of Wisconsin Study Area) (OCN 0964)
Vice President Government and Regulatory Affairs
VERIZON
ONE VERIZON WAY, MAIL CODE:180WVB (T)
BASKING RIDGE, NJ 07920 (T)

ACCESS SERVICE

TABLE OF CONTENTS

Table of Contents	1
Concurring Carriers	9
Connecting Carriers	9
Other Participating Carriers	9
Explanation of Symbols	10
Explanation of Abbreviations	10
Reference to Other Tariffs	13
Reference to Technical Publications	13
Reference to Other Publications	15
1. <u>APPLICATION OF TARIFF</u>	1-1
2. <u>GENERAL REGULATIONS</u>	
2.1 <u>Undertaking of the Telephone Company</u>	2-1
2.1.1 Scope	
2.1.2 Limitations	
2.1.3 Liability	
2.1.4 Provision of Services	
2.1.5 Installation and Termination of Services	
2.1.6 Maintenance of Services	
2.1.7 Changes and Substitutions	
2.1.8 Discontinuance and Refusal of Services	
2.1.9 Limitation of Use of Metallic Facilities	
2.1.10 Notification of Service-Affecting Activities	
2.1.11 Coordination with Respect to Network Contingencies	
2.1.12 RESERVED	
2.2 <u>Use</u>	2-9
2.2.1 Interference or Impairment	
2.2.2 Unlawful Use	

ACCESS SERVICE

TABLE OF CONTENTS (Cont'd)

2.	<u>GENERAL REGULATIONS (Cont'd)</u>	
2.3	<u>Obligations of the Customer</u>	2-10
	2.3.1 Damages	
	2.3.2 Ownership of Facilities and Theft	
	2.3.3 Equipment Space and Power	
	2.3.4 Availability for Testing	
	2.3.5 Balance	
	2.3.6 Design of Customer Services	
	2.3.7 References to the Telephone Company	
	2.3.8 Claims and Demands for Damages	
	2.3.9 Coordination with Respect to Network Contingencies	
	2.3.10 Jurisdictional Report Requirements	
	2.3.11 Determination of Interstate Charges for Mixed Interstate and Intrastate Access Service	
2.4	<u>Payment Arrangements and Credit Allowances</u>	2-21
	2.4.1 Payment of Rates, Charges and Deposits	
	2.4.2 Minimum Periods	
	2.4.3 Cancellation of an Order for Service	
	2.4.4 Credit Allowance for Service Interruptions	
	2.4.5 Re-establishment of Service Following Fire, Flood or other Occurrence	
	2.4.6 Title or Ownership Rights	
	2.4.7 Ordering, Rating and Billing of Access Services Where More than One Exchange Telephone Company is Involved	
	2.4.8 Reserved For Future Use	(C)
	2.4.9 Service Assurance Warranty Plan	
2.5	<u>Connections</u>	2-43
	2.5.1 General	
2.6	<u>Definitions</u>	2-44

ACCESS SERVICE

TABLE OF CONTENTS (Cont'd)

3.	<u>RESERVED FOR FUTURE USE</u>	3-1
4.	<u>RESERVED FOR FUTURE USE</u>	4-1
5.	<u>ORDERING OPTIONS FOR SPECIAL ACCESS SERVICE</u>	5-1
5.1	<u>General</u>	5-1
	5.1.1 Ordering Conditions	
	5.1.2 Provision of Other Services	
5.2	<u>Access Order</u>	5-4
	5.2.1 Access Order Service Date Intervals	
	5.2.2 Access Order Modifications	
	5.2.3 Cancellation of an Access Order	
	5.2.4 Selection of Facilities For Access Orders	
	5.2.5 Minimum Period	
	5.2.6 Minimum Period Charges	
	5.2.7 Shared Use Facilities	
5.3	<u>Common Channel Signaling Network Configuration</u>	5-16
6.	<u>RESERVED FOR FUTURE USE</u>	6-1

ACCESS SERVICE

TABLE OF CONTENTS (Cont'd)

7.	<u>SPECIAL ACCESS SERVICE</u>	
7.1	<u>General</u>	7-1
	7.1.1 Channel Types	
	7.1.2 Rate Categories	
	7.1.3 Service Configurations	
	7.1.4 Alternate Use	
	7.1.5 Special Facilities Routing	
	7.1.6 Design Layout Report	
	7.1.7 Acceptance Testing	
	7.1.8 Ordering Options and Conditions	
7.2	<u>Service Descriptions</u>	7-11
	7.2.1 Metallic Service	
	7.2.2 Telegraph Grade Service	
	7.2.3 Voice Grade Service	
	7.2.4 Program Audio Service	
	7.2.5 Digital Data Service	
	7.2.6 High Capacity Service	
7.3	<u>Channel Interface and Network Channel Codes</u>	7-38
	7.3.1 Glossary of Channel Interface Codes and Options	
	7.3.2 Impedance	
	7.3.3 Digital Hierarchy Channel Interface Codes	
	7.3.4 Service Designator/Network Channel Code Conversion Table	
	7.3.5 Compatible Channel Interfaces	
7.4	<u>Rate Regulations</u>	7-50
	7.4.1 Types of Rates and Charges	
	7.4.2 Surcharge for Special Access Service	
	7.4.3 Minimum Periods	
	7.4.4 Moves	
	7.4.5 Mileage Measurement	
	7.4.6 Facility Hubs	
	7.4.7 Shared Use Digital High Capacity Services	
	7.4.8 Term Discount Plans # See Footnote on Page 7-61	
7.5	<u>Expanded Interconnection Service</u>	7-63
	7.5.1 General	
	7.5.2 Service Description	
	7.5.3 Types of Charges	

ACCESS SERVICE

TABLE OF CONTENTS (Cont'd)

8.	<u>ADVANCED COMMUNICATIONS SERVICES</u>	
8.1	<u>SONET Special Access Service</u>	8-1
	8.1.1 Service Description	
	8.1.2 SONET Node	
	8.1.3 SONET Link	
	8.1.4 SONET Interoffice Mileage	
	8.1.5 SONET Port	
	8.1.6 SONET Reconfiguration Charge	
	8.1.7 Rate Regulations	
9.	<u>GRANDFATHERED SERVICES</u>	
9.1	<u>General</u>	9-1

ACCESS SERVICE

TABLE OF CONTENTS (Cont'd)

10.	<u>RESERVED FOR FUTURE USE</u>	10-1
11.	<u>SPECIAL FACILITIES ROUTING OF ACCESS SERVICES</u>	
11.1	<u>Description of Special Facilities Routing of Access Services</u>	11-1
	11.1.1 Diversity	
	11.1.2 Avoidance	
	11.1.3 Cable-Only Facilities	
11.2	<u>Rates and Charges for Special Facilities Routing of Access Services</u>	11-2
	11.2.1 Diversity	
	11.2.2 Avoidance	
	11.2.3 Diversity and Avoidance Combined	
	11.2.4 Cable-Only Facilities	

ACCESS SERVICE

TABLE OF CONTENTS (Cont'd)

12.	<u>RESERVED FOR FUTURE USE</u>	12-1
13.	<u>ADDITIONAL ENGINEERING, ADDITIONAL LABOR AND MISCELLANEOUS SERVICES</u>	
13.1	<u>Additional Engineering</u>	13-1
13.2	<u>Additional Labor</u>	13-1
	13.2.1 Overtime Installation	
	13.2.2 Overtime Repair	
	13.2.3 Stand by	
	13.2.4 Testing and Maintenance with Other Telephone Companies	
	13.2.5 Other Labor	
13.3	<u>Miscellaneous Services</u>	13-2
	13.3.1 Maintenance of Service	
	13.3.2 Emergency Services	
	13.3.3 Reserved	
	13.3.4 Reserved	
	13.3.5 Reserved	
	13.3.6 Testing Services	
	13.3.7 Provision of Access Service Billing Information	

ACCESS SERVICE

TABLE OF CONTENTS (Cont'd)

14.	<u>EXCEPTIONS TO ACCESS SERVICE OFFERINGS</u>	14-1
15.	<u>Contract Services</u>	15-1
16.	<u>RATES AND CHARGES</u>	
16.1	<u>RESERVED FOR FUTURE USE</u>	16-1
16.2	<u>RESERVED FOR FUTURE USE</u>	16-2
16.3	<u>RESERVED FOR FUTURE USE</u>	16-3
16.4	<u>RESERVED FOR FUTURE USE</u>	16-4
16.5	<u>Special Access</u>	16-10
16.6	<u>SONET Special Access Service</u>	16-39
16.7	<u>RESERVED FOR FUTURE USE</u>	16-45
16.8	<u>Miscellaneous Services</u>	16-47
16.9	<u>RESERVED FOR FUTURE USE</u>	16-53
16.10	<u>Competitive Counties for Special Access</u>	16-54

ACCESS SERVICE

NO CONCURRING CARRIERS

NO CONNECTING CARRIERS

NO OTHER PARTICIPATING CARRIERS

THE FOLLOWING REGISTERED SERVICE MARKS AND TRADEMARKS
ARE REFERENCED IN THIS GUIDE:

REGISTERED SERVICE MARKS

REGISTERED TRADEMARKS

DATAPHONE

DATAPHONE

ACCESS SERVICE

EXPLANATION OF SYMBOLS

(C)	-	To signify changed regulation
(D)	-	To signify discontinued rate or regulation
(I)	-	To signify increase
(M)	-	To signify matter relocated without change
(N)	-	To signify new rate or regulation
(R)	-	To signify reduction
(T)	-	To signify change in text but no change in rate or regulation
(Z)	-	To signify a correction
(S)	-	Reissued matter

EXPLANATION OF ABBREVIATIONS

ac	-	Alternating current
ACM	-	Address Complete Message
AML	-	Actual Measured Loss
ANI	-	Automatic Number Identification
AP	-	Program Audio
ARC	-	Access Recovery Charge
AT&T	-	American Telephone and Telegraph Company
BD	-	Business Day
BHMC	-	Busy Hour Minutes of Capacity
CAROT	-	Centralized Automatic Reporting on Trunks
CCS	-	Centralized Channel Signalling
CCSN	-	Common Channel Signalling Network
CCSNC	-	Common Channel Signalling Network Connection
CI	-	Changes Interface
CO	-	Central Office
COCTX	-	Central Office Centrex
Cont'd	-	Continued
CPE	-	Customer Provided Equipment
CPN	-	Calling Party Number
CSP	-	Carrier Selection Parameter
Ctx	-	Centrex
DA	-	Directory Assistance
db	-	Decibel
dBrnC	-	Decibel Reference Noise C-Message Weighting
dBrnCO	-	Decibel Reference Noise C-Message Referenced to 0
dBV	-	Decibel(s) relative to 1 volt (reference)
dc	-	direct current
DDA	-	Digital Data Access

(N)

ACCESS SERVICE

EXPLANATION OF ABBREVIATIONS (Cont'd)

EDD	-	Envelope Delay Distortion
ELEPL	-	Equal Level Echo Path Loss
EML	-	Expected Measure Loss
EPL	-	Echo Path Loss
ERL	-	Echo Return Loss
ESS	-	Electronic Switching System
ESSX	-	Electronic Switching System Exchange
EXM	-	Exit Message
f	-	frequency
FID	-	Field Identifier
F.C.C.	-	Federal Communications Commission
FX	-	Foreign Exchange
HC	-	High Capacity
Hz	-	Hertz
IC	-	Interstate Customer
ICB	-	Individual Case Basis
ICL	-	Inserted Connection Loss
kbps	-	kilobits per second
kHz	-	kilohertz
LATA	-	Local Access and Transport Area
Ma	-	milliamperes
Mbps	-	Megabits per second
MHz	-	Megahertz
MMUC	-	Minimum Monthly Usage Charge
MRC	-	Monthly Recurring Charge
MT	-	Metallic
MTS	-	Message Telecommunications Service(s)
MTS/WATS Service	-	Message Telecommunications Service and/or Wide Area Telecommunications Service
MTS/WATS	-	Execunet/Sprint - type Interstate Service which MCI type Telecommunications Corporation presently markets as Execunet and Network Service and which GTE Spring (formerly Southern Pacific Communications Company) Markets as Sprint IV and V or any other like service offered by those companies and/or other common carriers
NPA	-	Numbering Plan Area
NRC	-	Nonrecurring Charge
NTS	-	Non-Traffic Sensitive
NXX	-	Three-Digit Central Office Code
OTPL	-	Zero Transmission Level Point

ACCESS SERVICE

EXPLANATION OF ABBREVIATIONS (Cont'd)

PBX	-	Private Branch Exchange
PCM	-	Pulse Code Modulation
PLR	-	Private Line Ringdown
POT	-	Point of Termination
rms	-	root-mean-square
RSM	-	Remote Switching Modules
RSS	-	Remote Switching Systems
SNAL	-	Signaling Network Access Link
SPOI	-	Signaling Point of Interface
SRL	-	Singing Return Loss
SSN	-	Switched Service Network
SS7	-	Signaling System 7
STP	-	Signaling Transfer Point
SWC	-	Serving Wire Center
TES	-	Telephone Exchange Service(s)
TG	-	Telegraph Grade
TLP	-	Transmission Level Point
TSPS	-	Traffic Service Position System
TV	-	Television
USOC	-	Uniform Service Order Code
VG	-	Voice Grade
V & H	-	Vertical & Horizontal
WA	-	Wideband Analog
WATS	-	Wide Area Telecommunications Service(s)
WD	-	Wideband Data

ACCESS SERVICE

REFERENCE TO OTHER TARIFFS

Whenever reference is made in this Guide to other tariffs of the Telephone Company, the reference is to the guides and tariffs in force as of the effective date of this Guide, and to amendments thereto and successive issues thereof.

REFERENCE TO TECHNICAL PUBLICATIONS

The following technical publications are referenced in this Guide and except for PUB AS No. 1 may be obtained from Literary Data Center, Inc., G.P.O. Box C-9104, Brooklyn, NY 11202:

Compatibility Bulletin 106, Issue 2
Issued: December, 1981 Available: March 11, 1992

Technical Reference:

PUB 41451*			
Issued:	January, 1983	Available:	May 17, 1983
PUB 60101			
Issued:	December, 1982	Available:	January 17, 1983
PUB 41004			
Issued:	October, 1973	Available:	October, 1973
PUB 62310			
Issued:	September, 1983	Available:	October, 1983
PUB 62411			
Issued:	September, 1983	Available:	October, 1983
PUB 62500			
Issued:	December, 1983	Available:	March 15, 1984
PUB 62501 and associated Addendum			
Issued:	December, 1983	Available:	March 15, 1984
PUB 62502			
Issued:	December, 1983	Available:	January, 1984
PUB 62503 and associated Addendum			
Issued:	December, 1983	Available:	March 15, 1984

* Status of this publication is in question regarding pending resolution of its applicability to Satellite Digital Service.

ACCESS SERVICE

REFERENCE TO TECHNICAL PUBLICATIONS (Cont'd)

PUB 62504 and associated Addendum
 Issued: December, 1983 Available: March 15, 1984

PUB 62505 and associated Addendum
 Issued: December, 1983 Available: January, 1984

PUB 62506
 Issued: December, 1983 Available: January, 1984

PUB 62507
 Issued: December, 1983 Available: March 15, 1984

PUB 62508
 Issued: December, 1983 Available: January, 1984

The following technical publication is referenced in this Guide and may be obtained from the Bell System Center for Technical Education, Room F214, 6200 Route 53, Lisle, IL 60532.

Telecommunications Transmission Engineering Volume 3-Networks and Services (Chapters 6 and 7)
 Second Edition, 1980

Issued: June 1980 Available June, 1980

The following technical publication is referenced in this Guide and may be obtained from the national Exchange Carrier Association, Inc. Group Manager - Tariff Administration, 100 S. Jefferson Road, Whippany, NJ 07981 and the Federal Communications Commission's commercial contractor.

PUB AS No. 1
 Issued: March, 1984 Available April, 1984

The following Ordering and Billing Forum Documents reference din this Guide may be obtained from the Exchange Carrier Standards Association, Four Century Drive, Parsippany, New Jersey 07054 and the Federal Communications Commission's commercial contractor.

Multiple Exchange Carrier Access Billing Guidelines (MECAB)
 Issued: November 9, 1987 Available: November 9, 1987

Multiple Exchange Carrier Ordering and Design Guidelines (MECOD)
 Issued: October 31, 1985 Available: October 31, 1985

The following publication is referenced in this Guide and may be obtained from Bell Communications Research, Inc. (Bellcore) 445 South Street, Room 2K-122, Box 1910, Morristown, New Jersey 07960-1910.

TR-NPL-000157
 Issue: April, 1986 Available: April, 1986

TR-NPL-000054
 Issued: April, 1989 Available: April, 1989

ACCESS SERVICE

REFERENCE TO TECHNICAL PUBLICATIONS (Cont'd)

The following technical publications are referenced in this Guide and may be obtained from Bell Communications Research, Inc. (Bellcore), 445 South Street, Room 2k-122, Box 1910, Morristown, New Jersey 07960-1910:

TA-TSY-000192 Issued: April, 1986	Available: April, 1986
TA-TSY-000280 Issued: May, 1986	Available: May, 1986
TR-TSV-000905 Issued: July 1, 1989	Available: July, 1989
TR-TSV-000954 Issued: December, 1990	Available: December, 1990

REFERENCE TO OTHER PUBLICATIONS

The following publication is reference in this Guide and may be obtained from the Government Printing Office, Superintendent of Documents, Document control Branch, 941 N. Capitol St. NE, Washington, D.C., 20401.

Telecommunications Service Priority System Handbook (NCS Handbook 3-1-2)

Issued: July 11, 1989	Available: September 10, 1990
-----------------------	-------------------------------

ACCESS SERVICE

2. General Regulations

2.1 Undertaking of the Telephone Company

2.1.1 Scope

(A) The Telephone Company does not undertake to transmit messages under this Guide.

(B) The Telephone Company shall be responsible only for the installation, operation and maintenance of the services which it provides.

(C) The Telephone Company will, for maintenance purposes, test its services only to the extent necessary to detect and/or clear troubles.

(D) Services are provided 24 hours daily, seven days per week, except as set forth in other applicable sections of this Guide.

(E) The Telephone Company does not warrant that its facilities and services meet standards other than those set forth in this Guide.

2.1.2 Limitations

(A) The Customer may not assign or transfer the use of services provided under this Guide; however, where there is not interruption of use or relocation of the services, such assignment or transfer may be made to:

(1) another Customer, whether an individual, partnership, association or corporation, provided the assignee or transferee assumes all outstanding indebtedness for such services, and the unexpired portion of the minimum period and the termination liability applicable to such services, if any; or

(2) a court-appointed receiver, trustee or other person acting pursuant to law in bankruptcy, receivership, reorganization, insolvency, liquidation or other similar proceedings, provided the assignee or transferee assumes the unexpired portion of the minimum period and the termination liability applicable to such services, if any.

ACCESS SERVICE

2. General Regulations (Cont'd)

2.1 Undertaking of the Telephone Company (Cont'd)

2.1.2 Limitations (Cont'd)

(A) (Cont'd)

In all cases of assignment or transfer, the written acknowledgment of the Telephone Company is required prior to such assignment or transfer which, after such acknowledgment shall be made within 15 days from the receipt of notification. All regulations and conditions contained in this Guide shall apply to such assignee or transferee.

The assignment or transfer of services does not relieve or discharge the assignor or transferor from remaining jointly or severally liable with the assignee or transferee for any obligations existing at the time of the assignment or transfer.

(B) The installation, use and restoration of services shall be in accordance with Part 64, Subpart D, Appendix A, of the Federal Communications Commission's Rules and Regulations, and shall be subject to the regulations set forth in Section 13.3.2(B), Telecommunications Service Priority (TSP) System.

(C) Subject to compliance with the rules mentioned in (B) preceding, where a shortage of facilities or equipment exists at any time, either for temporary or protracted periods, the services offered herein will be provided to customers on a first-come first-served basis. First-come first-served shall be based upon the received time and date stamped by the Telephone Company on complete and accurate customer orders which allow the Telephone Company to initiate its ordering process. Inaccurate or incomplete customer orders shall not be deemed to have been received until such time as the customer corrects such inaccuracies and/or omissions. The customer shall not be penalized for any delay in the Telephone Company review process beyond 24 hours of receipt. Once having been advised of the errors and/or omissions any delay in correction on the part of the customer shall be added to the received time.

ACCESS SERVICE

2. General Regulations (Cont'd)

2.1 Undertaking of the Telephone Company (Cont'd)

2.1.3 Liability

(A) The Telephone Company's liability, if any, for its willful misconduct is not limited by this Guide. With respect to any other claim or suit, by a Customer or by any others, for damages associated with the preemption installation, provision, termination, maintenance, repair or restoration of service, and subject to the provisions of (B) through (I) following, the Telephone Company's liability, if any, shall not exceed an amount equal to the proportionate charge for the service for the period during which the service was affected. This liability for damages shall be in addition to any amounts that may otherwise be due to the Customer under this Guide as a Credit Allowance for a Service Interruption.

(B) The Telephone Company shall not be liable for any act or omission of any other carrier or Customer providing a portion of a service, nor shall the Telephone Company for its own act or omission hold liable any other carrier or Customer providing a portion of a service.

(C) The Telephone Company is not liable for damages to the Customer premises resulting from the furnishing of a service, including the installation and removal of equipment and associated wiring, unless the damage is caused by the Telephone Company's negligence.

(D) The Telephone Company shall be indemnified, defended and held harmless by the IC or End User against any claims, loss or damage arising from the use of services offered under this Guide, involving;

(1) Claims for libel, slander, invasion of privacy, or infringement of copyright arising from the End User's own communications;

(2) Claims for patent infringement arising from the End User's acts combining or using the service furnished by the Telephone Company in connection with facilities or equipment furnished by the End User or IC or;

(3) All other claims arising out of any act or omission of the End User in the course of using services provided pursuant to this Guide.

ACCESS SERVICE

2. General Regulations (Cont'd)

2.1 Undertaking of the Telephone Company (Cont'd)

2.1.3 Liability (Cont'd)

(E) The Telephone Company shall be indemnified, defended and held harmless by the IC against any claim, loss or damage arising from the IC's use of services offered under this Guide involving:

(1) Claims for libel, slander, invasion of privacy, or infringement of copyright arising from the IC's own communications;

(2) Claims for patent infringement arising from the IC's acts combining or using the service furnished by the Telephone Company in connection with facilities or equipment furnished by the end user or IC or;

(3) All other claims arising out of any act or omission of the IC in the course of using services provided pursuant to this Guide.

(F) The Telephone Company does not guarantee or make any warranty with respect to its services when used in an explosive atmosphere. The Telephone Company shall be indemnified, defended and held harmless by the Customer from any and all claims by any person relating to such customer's use of services so provided.

(G) No license under patents (other than the limited license to use) is granted by the Telephone Company or shall be implied or arise by estoppel, with respect to any service offered under this Guide. The Telephone Company will defend the Customer against claims of patent infringement arising solely from the use by the Customer of services offered under this Guide and will indemnify such Customer for any damages awarded based solely on such claims.

(H) Where an Exchange Telephone Company that jointly provides access service with the Telephone Company is incapable of denying such service in compliance with its tariffs without the cooperation of the Telephone Company, the Telephone Company will assist that Exchange Telephone Company in denying joint access service to the customer as long as that Exchange Telephone Company indemnifies, defends and holds harmless the Telephone Company from and against any and all liability, loss, damages, costs, claims or expenses of any kind arising out of the Telephone Company's assistance in the denial of service. Service denial for such joint service will only include calls which originate or terminate within, or transit, the operating territory of the Exchange Telephone Company (Companies) initiating the service denial.

ACCESS SERVICE

2. General Regulations (Cont'd)

2.1 Undertaking of the Telephone Company (Cont'd)

2.1.3 Liability (Cont'd)

(l) The Telephone Company's failure to provide or maintain services under this Guide shall be excused by labor difficulties, governmental orders, civil commotion's, criminal actions taken against the Telephone Company, acts of God and other circumstances beyond the Telephone Company's reasonable control, subject to the Credit Allowance for a Service Interruption as set forth in 2.4.4 following.

2.1.4 Provision of Services

The Telephone Company, to the extent that such services are or can be made available with reasonable effort, and after provision has been made for the Telephone Company's telephone exchange services, will provide to the Customer upon reasonable notice services offered in other applicable sections of this Guide at rates and charges specified therein.

2.1.5 Installation and Termination of Services

The services provided under this Guide (A) will include any entrance cable or drop wiring and wire or intrabuilding cable to that point where provision is made for termination of the Telephone Company's outside distribution network facilities at a suitable location inside a Customer-designated premises and (B) will be installed by the Telephone Company to such Point of Termination. Wire, required within a building to extend Access Service facilities, will be provided, at the Customer's request, on a time sensitive charge basis. The labor rates for the installation of such wire are the same as those set forth in Section 16 following for Other Labor.

2.1.6 Maintenance of Services

The services provided under this Guide shall be maintained by the Telephone Company. The Customer or others may not rearrange, move, disconnect, remove or attempt to repair any facilities provided by the Telephone Company, other than by connection or disconnection to any interface used, except with the written consent of the Telephone Company.

ACCESS SERVICE

2. General Regulations (Cont'd)

2.1 Undertaking of the Telephone Company (Cont'd)

2.1.7 Changes and Substitutions

Except as provided for equipment and systems subject to FCC Part 68 regulations at 47 C.F.R. S68.110(b), the Telephone Company may, where such action is reasonably required in the operation of its business, (A) substitute, change or rearrange any facilities used in providing service under this Guide, including but not limited to, (1) substitution of different metallic facilities, (2) substitution of carrier or derived facilities for metallic facilities used to provide other than metallic facilities and (3) substitution of metallic facilities for carrier or derived facilities used to provide other than metallic facilities, (B) change minimum protection criteria, (C) change operating or maintenance characteristics of facilities or (D) change operations or procedures of the Telephone Company. In case of any such substitution, change or rearrangement, the transmission parameters will be within the range as set forth in Sections 6 and 7 following. The Telephone Company shall not be responsible if any such substitution, change or rearrangement renders any Customer furnished services obsolete or requires modification or alteration thereof or otherwise affects their use or performance. If such substitution, change or rearrangement materially affects the operating characteristics of the facility, the Telephone Company will provide reasonable notification to the customer in writing. Reasonable time will be allowed for any redesign and implementation required by the change in operating characteristics. The Telephone Company will work cooperatively with the customer to determine reasonable notification procedures.

ACCESS SERVICE

2. General Regulations (Cont'd)

2.1 Undertaking of the Telephone Company (Cont'd)

2.1.8 Discontinuance and Refusal of Services

(A) Unless the provisions of 2.2.2 (B) or 2.5.1 following apply, if the Customer fails to comply with 2.1.6 preceding or 2.2.2, 2.3.1, 2.3.4, 2.3.5 or 2.4 following, including any payments to be made by it on the dates or at the times herein specified, the Telephone Company may, on thirty (30) days written notice by Certified US Mail to the person designated by the Customer to receive such notices of noncompliance, refuse additional applications for service and/or refuse to complete any pending orders for service for the noncomplying customer at any time thereafter.

If the Telephone Company does not refuse additional applications for service on the date specified in the thirty (30) days notice, and the Customer's noncompliance continues, nothing contained herein shall preclude the Telephone Company's right to refuse additional applications for service to the noncomplying customer without further notice.

(B) Unless the provisions of 2.2.2(B) or 2.5 following apply, if a Customer fails to comply with 2.1.6 preceding or 2.2.2, 2.3.1, 2.3.4, 2.3.5 or 2.4 following, including any payments to be made by it on the dates and times herein specified, the Telephone Company may, on thirty (30) days written notice by Certified US Mail to the person designated by that Customer to receive such notices of noncompliance, discontinue the provision of the services to the non-complying customer involved at any time thereafter. In the case of such discontinuance, all applicable charges, including termination charges, shall become due. If the Telephone Company does not discontinue the provision of the services involved on the date specified in the thirty (30) days notice, and the Customer's noncompliance continues, nothing contained herein shall preclude the Telephone Company's right to discontinue the provision of the services to the non-complying customer without further notice.

(C) If the National Exchange Carrier Association, Inc. notifies the Telephone Company that the Customer has failed to comply with Section 8 of the National Exchange Carrier Association, Inc., Tariff F.C.C. No 5 (Lifeline Assistance and Universal Service Fund charges), including any Customer's failure to make payments on the date and times specified therein, the Telephone Company may, on thirty days' written notice to the Customer by Certified US Mail, take any of the following actions: (1) refuse additional applications for service and/or (2) refuse to complete any pending orders for service, (3) discontinue the provision of service to the Customer. In the case of discontinuance, all applicable charges including termination charges, shall become due.

ACCESS SERVICE

2. General Regulations (Cont'd)

2.1 Undertaking of the Telephone Company (Cont'd)

2.1.9 Limitation of Use of Metallic Facilities

Signals applied to a metallic facility shall conform to the limitations set forth in Technical Reference Publication AS No. 1. In the case of application of dc telegraph signaling systems, the Customer shall be responsible, at its expense, for the provision of current limiting devices to protect the Telephone Company facilities from excessive current due to abnormal conditions and for the provision of noise mitigation networks when required to reduce excessive noise.

2.1.10 Notification of Service-Affecting Activities

The Telephone Company will provide the Customer reasonable notification of service-affecting activities that may occur in normal operation of its business. Such activities may include, but are not limited to, equipment or facilities additions, removals or rearrangements, routine preventative maintenance and major switching machine change-out. Generally, such activities are not individual Customer service specific, they affect many Customer services. No specific advance notification period is applicable to all service activities. The Telephone Company will work cooperatively with the Customer to determine the modification requirements.

2.1.11 Coordination with Respect to Network Contingencies

The Telephone Company intends to work cooperatively with the Customer to develop network contingency plans in order to maintain maximum network capability following natural or man-made disasters which affect telecommunications services.

2.1.12 RESERVED

ACCESS SERVICE

2. General Regulations (Cont'd)

2.2 Use

2.2.1 Interference or Impairment

(A) The characteristics and methods of operation of any circuits, facilities or equipment provided by other than the Telephone Company and associated with the facilities utilized to provide services under this Guide shall not interfere with or impair service over any facilities of the Telephone Company, its affiliated companies, or its connecting and concurring carriers involved in its services, cause damage to their plant, impair the privacy of any communications carried over their facilities or create hazards to the employees of any of them or the public.

(B) Except as provided for equipment or systems subject to the FCC Part 68 rules in 47 C.F.R. S68.108, if such characteristics or methods of operation are not in accordance with (A) preceding, the Telephone Company will, where practicable, notify the Customer that temporary discontinuance of the use of a service may be required; however, where prior notice is not practicable, nothing contained herein shall be deemed to preclude the Telephone Company's right to temporarily discontinue forthwith the use of a service if such action is reasonable under the circumstances. In case of such temporary discontinuance, the Customer will be promptly notified and afforded the opportunity to correct the condition which gave rise to the temporary discontinuance. During such period of temporary discontinuance, credit allowance for service interruptions as set forth in 2.4.4 following is not applicable.

2.2.2 Unlawful Use

(A) The service provided under this Guide shall not be used for an unlawful purpose.

(B) The Telephone Company shall, upon written request from a customer, terminate service to any subscriber of a customer identified by that customer as having utilized that customer's service and/or facilities in the completion of abusive telephone calls. Service shall be terminated by the Telephone Company as provided for in its general or local exchange service.

(C) In such instances when termination occurs, as in (B) preceding, the Telephone Company shall be identified, defended and held harmless by the customer against any claim, loss or damage arising from the Telephone Company actions in terminating such service.

ACCESS SERVICE

2. General Regulations (Cont'd)

2.3 Obligations of the Customer

2.3.1 Damages

The Customer shall reimburse the Telephone Company for damages to Telephone Company facilities utilized to provide services under this Guide caused by the negligence or willful act of the Customer, or resulting from improper use of the Telephone Company facilities, or due to malfunction of any facilities or equipment provided by other than the Telephone Company. Nothing in the foregoing provision shall be interpreted to hold one customer liable for another customer's actions. The Telephone Company will, upon reimbursement for damages, cooperate with the Customer in prosecuting a claim against the person causing such damage and the Customer shall be subrogated to the right of recovery by the Telephone Company for the damages to the extent of such payment.

2.3.2 Ownership of Facilities and Theft

Facilities utilized by the Telephone Company to provide service under the provisions of this Guide shall remain the property of the Telephone Company. Such facilities shall be returned to the Telephone Company by the Customer, whenever requested, within a reasonable period following the request in as good condition as reasonable wear will permit.

2.3.3 Equipment Space and Power

The Customer shall furnish or arrange to have furnished to the Telephone Company, at no charge, equipment space and electrical power required by the Telephone Company to provide services under this Guide at the points of termination of such services. The selection of ac or dc power shall be mutually agreed to by the Customer and the Telephone Company. The Customer shall also make necessary arrangements in order that the Telephone Company will have access to such spaces at reasonable times for installing, testing, repairing or removing Telephone Company services.

ACCESS SERVICE

2. General Regulations (Cont'd)

2.3 Obligations of the Customer (Cont'd)

2.3.4 Availability for Testing

The services provided under this Guide shall be available to the Telephone Company at times mutually agreed upon in order to permit the Telephone Company to make tests and adjustments appropriate for maintaining the services in satisfactory operating condition. Such tests and adjustments shall be completed within a reasonable time. No credit will be allowed for any interruption during such tests and adjustments.

2.3.5 Balance

All signals for transmission over the services provided under this Guide shall be delivered by the Customer balanced to ground except for ground start, duplex (DX) and McCulloh-Loop (Alarm System) type signaling and dc telegraph transmission at speeds of 75 baud or less.

2.3.6 Design of Customer Services

Subject to the provisions of 2.1.7 preceding, the Customer shall be responsible at its own expense for the overall design of its services and for any redesigning or rearrangement of its services which may be required because of changes in facilities, operations or procedures of the Telephone Company, minimum protection criteria or operating or maintenance characteristics of the facilities.

2.3.7 References to the Telephone Company

The Customer may advise End Users that certain services are provided by the Telephone Company in connection with the service the Customer furnishes to End Users; however, the Customer shall not represent that the Telephone Company jointly participates in the Customer's services.

ACCESS SERVICE

2. General Regulations (Cont'd)

2.3 Obligations of the Customer (Cont'd)

2.3.8 Claims and Demands for Damages

(A) With respect to claims of patent infringement made by third persons, the Customer shall defend, indemnify, protect and save harmless the Telephone Company from and against all claims arising out of the combining with, or use in connection with, the services provided under this Guide, any circuit, apparatus, system or method provided by the Customer.

(B) The Customer shall defend, indemnify and save harmless the Telephone Company from and against suits, claims, and demands by third persons arising out of the construction, installation, operation, maintenance, or removal of the Customer's circuits, facilities, or equipment connected to the Telephone Company's services provided under this Guide, including, without limitation, Workmen's Compensation claims, actions for infringement of copyright and/or unauthorized use of program material, libel and slander actions based on the content of communications transmitted over the Customer's circuits, facilities or equipment, and proceedings to recover taxes, fines, or penalties for failure of the Customer to obtain or maintain in effect any necessary certificates, permits, licenses, or other authority to acquire or operate the services provided under this Guide; provided, however, the foregoing indemnification shall not apply to suits, claims, and demands are based on the tortuous conduct of the Customer, its officers, agents or employees.

(C) The Customer shall defend, indemnify and save harmless the Telephone Company from and against any suits, claims, losses or damages, including punitive damages, attorney fees and court costs by the Customer or third parties arising out of any act or omission of the Customer in the course of using services provided under this Guide.

2.3.9 Coordination with respect to Network Contingencies

The Customer shall, in cooperation with the Telephone Company, coordinate in planning the actions to be taken to maintain maximum network capability following natural or man-made disasters which affect telecommunications services.

ACCESS SERVICE

- 2. General Regulations (Cont'd)
 - 2.3 Obligations of the Customer (Cont'd)
 - 2.3.10 Jurisdictional Report Requirements
 - (A) Jurisdictional Reports
-

ACCESS SERVICE

- 2. General Regulations (Cont'd)
 - 2.3 Obligations of the Customer (Cont'd)
 - 2.3.10 Jurisdictional Report Requirements (Cont'd)
 - (A) Jurisdictional Reports (Cont'd)
-

ACCESS SERVICE

- 2. General Regulations (Cont'd)
 - 2.3 Obligations of the Customer (Cont'd)
 - 2.3.10 Jurisdictional Report Requirements (Cont'd)
 - (A) Jurisdictional Reports (Cont'd)
-

ACCESS SERVICE

- 2. General Regulations (Cont'd)
 - 2.3 Obligations of the Customer (Cont'd)
 - 2.3.10 Jurisdictional Report Requirements (Cont'd)
 - (A) Jurisdictional Reports (Cont'd)
-

ACCESS SERVICE

- 2. General Regulations (Cont'd)
- 2.3 Obligations of the Customer (Cont'd)
- 2.3.10 Jurisdictional Report Requirements (Cont'd)
- (A) Jurisdictional Reports (Cont'd)
- (7) (Cont'd)

ACCESS SERVICE

2. General Regulations (Cont'd)

2.3 Obligations of the Customer (Cont'd)

2.3.10 Jurisdictional Report Requirements (Cont'd)

(B) Jurisdictional Reports - Special Access

(1) When mixed interstate and intrastate special access services is provided, the jurisdiction will be determined as follows:

If the customer's estimate of interstate traffic on a special access circuit constitutes 10% or less of the total traffic on a particular circuit, the circuit will be provided in accordance with the applicable rules and regulations of the appropriate intrastate tariff.

If the customer's estimate of interstate traffic on a special access circuit constitutes more than 10% of the total traffic on a particular circuit, the circuit will be provided in accordance with the applicable rules and regulations of this Guide.

(2) A customer with one or more special access circuits provided under this Guide shall certify that interstate usage on each interstate circuit exceeds ten (10) percent of the total usage on each such circuit. Such certification shall be furnished pursuant to one of the following procedures:

(a) When submitting a formal service order, the customer may include the required certification with each order. The customer shall identify each interstate circuit ordered and clearly designate the customer's jurisdictional determination for each circuit.

(b) The customer may include the required certification in written correspondence with the Telephone Company which specifically identifies each circuit for which the certification is furnished and clearly designates the customer's jurisdictional determination for each circuit.

ACCESS SERVICE

2. General Regulations (Cont'd)

2.3 Obligations of the Customer (Cont'd)

2.3.10 Jurisdictional Report Requirements (Cont'd)

(B) Jurisdictional Reports - Special Access (Cont'd)

(2) (Cont'd)

(c) With respect to existing customers of interstate special access circuits as of the effective date of this section, such customers with 90 days of the effective date shall include the required certification in written correspondence with the Telephone Company which specifically identifies each interstate circuit currently provided to the customer and clearly designates the customer's jurisdictional determination of each circuit.

In the event that no certification is provided by a customer pursuant to subsection (c) above within ninety (90) days of the effective date of this section, this jurisdiction of special access circuits provided to such customers under this Guide shall be assumed to be interstate until such time as the customer provides written certification.

(3) If a billing dispute arises, or a regulatory commission questions the customer-provided certification, the Telephone Company will ask the customer to provide the information, including if applicable, records of system design and functions and any calculations, on which the customer relied in certifying the jurisdictional classifications of the circuit. The customer shall supply the data within 30 days of the Telephone Company request.

(4) For a period of sixty (60) days after the effective date of this provision, a customer with a special access circuit provided under this Guide for which the customer is subject to liability for termination prior to a specified date who determines that the jurisdiction of such circuit has changed solely as a result of the separations revisions required by the FCC's Decision and Order (89-224) shall not be subject to a penalty or other liability based on such jurisdictional change.

ACCESS SERVICE

2. General Regulations (Cont'd)

2.3 Obligations of the Customer (Cont'd)

2.3.11 Determination of Interstate Charges for Mixed Interstate and Intrastate Access Service

When mixed interstate and intrastate Access Service is provided, all charges (i.e., nonrecurring, and/or usage) including optional features charges, will be prorated between interstate and intrastate. The percentage provided in the reports as set forth in 2.3.10(A) preceding will serve as the basis for prorating the charges. The percentage of an Access Service to be charged as interstate is applied in the following manner:

(A) For nonrecurring chargeable rate elements, multiply the percent interstate use times the quantity of chargeable elements times the stated tariff rate per element.

(B) For usage sensitive (i.e., access minutes and calls) chargeable rate elements, multiply the percent interstate use times actual use (i.e., measured or Telephone Company assumed average use) times the stated tariff rate.

The interstate percentage will change as revised usage reports are submitted as set forth in 2.3.10 preceding.

ACCESS SERVICE

2. General Regulations (Cont'd)

2.4 Payment Arrangements and Credit Allowances

2.4.1 Payment of Rates, Charges and Deposits

(A) The Telephone Company will, in order to safeguard its interests, only require a Customer which has a proven history of late payments to the Telephone Company or does not have established credit except for a Customer which is a successor of a company which has established credit with the Telephone Company and has no history of late payments to the Telephone Company, to make a deposit prior to or at any time after the provision of a service to the Customer to be held by the Telephone Company as a guarantee of the payment of rates and charges. No such deposit will be required of a customer which is a successor of a company which has established credit and has no history of late payments to the Telephone Company. Such deposit may not exceed the actual or estimated rates and charges for the service for a two month period. The fact that a deposit has been made in no way relieves the Customer from complying with the Telephone Company's regulations as to the prompt payment of bills. At such time as the provision of the service to the Customer is terminated, the amount of the deposit will be credited to the Customer's account and any credit balance which may remain will be refunded. The deposit will be credited to the Customer's account when the Customer has established credit or, in any event, has established a one-year prompt record of payment at any time prior to the termination of the provision of service to the Customer. In case of a cash deposit, for the period the deposit is held by the Telephone Company, the Customer will receive simple annual interest at the rate specified by the New York State Public Service Commission. Should a deposit be credited to the Customer's account, as indicated above, no interest will accrue on the deposit from the date such deposit is credited to the Customer's account.

(B) The Telephone Company shall bill on a current basis all charges incurred by and credits due to the Customer under this Guide attributable to services established or discontinued during the preceding billing period.

In addition, the Telephone Company shall bill in advance charges for all services to be provided during the ensuing billing period except for charges associated with service usage and for the Federal Government which will be billed in arrears. Customers providing service to the Federal Government are not entitled to the benefits of the laws or regulations providing for billing in arrears, so they will be billed in advance for services as stated above.

ACCESS SERVICE

2. General Regulations (Cont'd)

2.4 Payment Arrangements and Credit Allowances (Cont'd)

2.4.1 Payment of Rates, Charges and Deposits (Cont'd)

(B) (Cont'd)

The bill day (i.e., the billing date of a bill for a Customer for Access Service under this Guide), the period of service each bill covers and the payment date will be as follows:

(1) For End User Access Service and Presubscription Service, the Telephone Company will establish a bill day each month for each end user account. The bill will cover End User Access Service and Presubscription Service charges for the ensuing billing period except for End User Access Service and Presubscription Service for the Federal Government which will be billed in arrears. Any known unbilled charges for prior periods and any known adjustments for prior periods and any known unbilled adjustments for prior periods for End User Access Service and Presubscription Service will be applied to this bill. Such bills are due when rendered.

(2) For Service other than End User Access Service and Presubscription Service, the Telephone Company will establish a bill day each month for each customer account or advise the customer in writing of an alternate billing schedule. Alternate billing schedules shall not be established on less than 60 days notice or initiated by the Telephone Company more than twice in any consecutive 12 month period. The bill will cover nonusage sensitive service charges for the ensuing billing period for which the bill is rendered, any known unbilled nonusage sensitive charges for prior periods and unbilled usage charges for that period after the last bill day through the current bill day. Any known unbilled usage charges for prior periods and any known unbilled adjustments will be applied to this bill.

Payment for such bills is due as set forth in (3) following. If payment is not received by the payment date, as set forth in (3) following in immediately available funds, a late payment penalty will apply as set forth in (3) following.

ACCESS SERVICE

2. General Regulations (Cont'd)

2.4 Payment Arrangements and Credit Allowances (Cont'd)

2.4.1 Payment of Rates, Charges and Deposits (Cont'd)

(B) (Cont'd)

(3) (a) All bills dated as set forth in (2) preceding for service, other than End User and Presubscription Service, provided to the Customer by the Telephone Company are due 30 days (payment date) after the bill day or by the next bill date (i.e., same date in the following month as the bill date), whichever is the shortest interval, except as provided herein, and are payable in immediately available funds. If such payment date would cause payment to be due on a Saturday, Sunday or Legal Holiday, payment for such bills will be due from the Customer on the last business day preceding the Saturday, Sunday or Legal Holiday.

(b) Further, if any portion of the payment is received by the Telephone Company after the payment date as set forth in (a) preceding, or if any portion of the payment is received by the Telephone Company in funds which are not immediately available to the Telephone Company, a late payment penalty shall be due to the Telephone Company. The late payment penalty shall be computed by first multiplying the portion of the payment not received or not received in immediately available funds by the payment date times a per day late factor which is equal to the highest rate which may be levied by law for commercial transactions. That result is then multiplied by the number of days after the payment date that the payment is received.

ACCESS SERVICE

2. General Regulations (Cont'd)

2.4 Payment Arrangements and Credit Allowances (Cont'd)

2.4.1 Payment of Rates, Charges and Deposits (Cont'd)

(B) (Cont'd)

(3) (Cont'd)

(c) Billing Disputes Resolved in Favor of the Telephone Company

In the event that a billing dispute concerning any charges billed to the Customer by the Telephone Company is resolved in favor of the Telephone Company, any payments withheld pending settlement of the dispute shall be subject to the late payment penalty set forth in (b) preceding.

A dispute for purposes of this section is defined as written notice to the Telephone Company with sufficient documentation to investigate the dispute.

If the customer disputes the bill on or before the payment date, and pays the undisputed amount on or before the payment due date, any late payment charge for the disputed amount will not start until ten (10) days after the payment due date. The late payment charge will continue to accrue until payment is received by the Telephone Company.

If the customer disputes the bill after the payment due date, and pays the undisputed amount after the payment due date, the late payment charge for the disputed amount shall begin on the payment due date.

(d) Billing Disputes Resolved in Favor of the Customer

In the event that a billing dispute concerning any charges billed to the customer by the Telephone Company is resolved in favor of the customer, any payments of the disputed amount, withheld pending settlement of the dispute shall not be subject to the late payment penalty.

ACCESS SERVICE

- 2. General Regulations (Cont'd)
- 2.4 Payment Arrangements and Credit Allowances (Cont'd)
- 2.4.1 Payment of Rates, Charges and Deposits (Cont'd)
- (B) (Cont'd)
- (3) (Cont'd)
- (d) (Cont'd)

The date of the dispute shall be the date the Telephone Company receives sufficient documentation to investigate the dispute.

The date of resolution is the date the Telephone Company completes its investigation and notifies the customer of the disposition of the dispute.

(C)

If the Customer disputes the billed amount and pays the total amount (i.e., the non-disputed amount and the disputed amount) on or before the payment due date and the billing dispute is resolved in the favor of the Customer, the Customer will receive a credit from the Telephone Company. The credit shall be the disputed amount resolved in the Customer's favor times a penalty factor, which is the rate authorized by the New York State Public Service Commission. This penalty factor will apply from the date of the customer's payment through the date of resolution by the Telephone Company.

(C)

ACCESS SERVICE

2. General Regulations (Cont'd)

2.4 Payment Arrangements and Credit Allowances (Cont'd)

2.4.1 Payment of Rates, Charges and Deposits (Cont'd)

(C) Adjustments for the quantities of services established or discontinued in any billing period beyond the minimum period set forth for services in other sections of this Guide will be prorated to the number of days or major fraction of days based on a 30 day month. The Telephone Company will, upon request and if available, furnish such detailed information as may reasonably be required for verification of any bill.

(D) When a rate as set forth in this Guide is shown to more than two decimal places, the charges will be determined using the rate shown. The resulting amount will then be rounded to the nearest penny (i.e., rounded to two decimal places).

(E) When more than one copy of a Customer bill for services provided under the provisions of this Guide is furnished to the Customer, an additional charge applies for each additional copy of the bill as set forth in 13.3.7 following.

(F) A Check Return Charge will apply whenever a check or draft presented for payment for service, deposit, or advance payment is not accepted by the institution on which it is written.

Check Return Charge, per check or draft returned \$10.00

(G) Upon request, the Telephone Company will furnish a customer the information used to calculate the customer bill in order to permit a customer to verify the accuracy of the bill. Such information shall be provided within a reasonable period of time but in no event later than the number of days in the customer bill cycle.

ACCESS SERVICE

2. General Regulations (Cont'd)

2.4 Payment Arrangements and Credit Allowances (Cont'd)

2.4.2 Minimum Periods

The minimum periods for which services are provided and for which rates and charges are applicable is one month except for those services set forth in 5.2.5(B), 13.3.6, and Section 12. following.

The minimum period for which service is provided and for which rates and charges are applicable for a Specialized Service or Arrangement provided on an individual case basis; as set forth in 12. following, is one month unless a different minimum period is established with the individual case filing.

When a service is discontinued prior to the expiration of the minimum period, charges are applicable whether the service is used or not, as follows:

(A) When a service with a one month minimum period is discontinued prior to the expiration of the minimum period, a one month charge will apply at the rate level in effect at the time service is discontinued.

(B) When a service with a minimum period greater than one month is discontinued prior to the expiration of the minimum period, the applicable charge will be the lesser of (1) the Telephone Company's total nonrecoverable costs less the net salvage value for the discontinued service or (2) the total monthly charge, at the rate level in effect at the time service is discontinued, for the remainder of the minimum period.

2.4.3 Cancellation of an Order for Service

Provisions for the cancellation of an order for service are set forth in other applicable sections of this Guide.

ACCESS SERVICE

2. General Regulations (Cont'd)

2.4 Payment Arrangements and Credit Allowances (Cont'd)

2.4.4 Credit Allowance for Service Interruptions

(A) General

A service is interrupted when it becomes unusable to the Customer because of a failure of a facility component used to furnish service under this Guide or in the event that the protective controls applied by the Telephone Company result in the complete loss of service by the customer as set forth in 6.5.1 following. An interruption period starts when an inoperative service, is reported to the Telephone Company, and ends when the service is operative.

(B) When Credit Allowance Applies

In case of an interruption to any service, allowance for the period of interruption, if not due to the negligence of the Customer, shall be as follows:

(1) For Special Access Services, other than Program Audio and Video Services and for flat rated Switched Access Service Transport rate elements (i.e., Entrance Facility, Direct Trunked Transport and Multiplexing), no credit shall be allowed for an interruption of less than thirty (30) minutes. The Customer shall be credited for an interruption of 30 minutes or more at the rate of 1/1440 of the monthly charge for the service for each period of 30 minutes or at least fifteen minutes thereof that the interruption continues.

The monthly charges used to determine the credit shall be as follows:

(a) For two-point services, the monthly charge shall be the total of all the monthly rate element charges associated with the service (i.e. two channel termination's, channel mileage and optional features and functions).

ACCESS SERVICE

2. General Regulations (Cont'd)

2.4 Payment Arrangements and Credit Allowances (Cont'd)

2.4.4 Credit Allowance for Service Interruptions (Cont'd)

(B) When Credit Allowance Applies (Cont'd)

(1) (Cont'd)

(b) For multipoint services, the monthly charge shall be only the total of all the monthly rate element charges associated with that portion of the service that is inoperative (i.e., a channel termination per customer designated premises, channel mileage and optional features and functions).

(c) For multiplexed services, the monthly charge shall be the total of all the monthly rate element charges associated with that portion of the service that is inoperative. When the facility which is multiplexed or the multiplexer itself is inoperative, the monthly charge shall be the total of all the monthly rate element charges associated with the service (i.e., the channel termination, channel mileage, Entrance Facility, Direct Trunked Transport and optional features and functions, including the multiplexer on the facility to the Hub, and the channel termination's, channel mileage's and optional features and functions on the individual services from the Hub). When the service which rides a channel of the multiplexed facility is inoperative, the monthly charge shall be the total of all the monthly rate element charges associated with that portion of the service from the Hub to a customer premises (i.e., channel termination's, channel mileage and optional features and functions).

ACCESS SERVICE

2. General Regulations (Cont'd)

2.4 Payment Arrangements and Credit Allowances (Cont'd)

2.4.4 Credit Allowance for Service Interruptions (Cont'd)

(B) When Credit Allowance Applies (Cont'd)

(2) For Program Audio and Video Special Access Services, no credit shall be allowed for an interruption of less than 30 seconds. The customer shall be credited for an interruption of 30 seconds or more as follows:

(a) For two-point services, when monthly rates are applicable, the credit shall be at the rate of 1/8640 of the monthly charges for the service for each period of 5 minutes or at least three minutes thereof that the interruption continues.

(b) For two-point services, when daily rates are applicable, the credit shall be at the rate of 1/288 of the daily charges for the service for each period of 15 minutes or at least eight minutes thereof that the interruption continues.

(c) For multipoint services, when monthly rates are applicable, the credit shall be at the rate of 1/8640 of the monthly charges for each Channel Termination, Channel Mileage and optional features and functions that is inoperative for each period of 5 minutes or at least three minutes thereof that the interruption continues.

(d) For multipoint services, when daily rates are applicable, the credit shall be at the daily rate of 1/288 of the daily charges for each Channel Termination, Channel Mileage and optional features and functions that is inoperative for each period of 5 minutes or at least three minutes thereof that the interruption continues.

(e) For multipoint services, the credit for the monthly or daily charges includes the charges for the distribution amplifier only when the distribution amplifier is inoperative.

(f) When two or more interruptions occur during a period of 5 consecutive minutes, such multiple interruptions shall be considered as one interruption.

ACCESS SERVICE

2. General Regulations (Cont'd)

2.4 Payment Arrangements and Credit Allowances (Cont'd)

2.4.4 Credit Allowance for Service Interruptions (Cont'd)

(B) When Credit Allowance Applies (Cont'd)

(3) For Switched Access Service and Directory Assistance Service, no credit shall be allowed for an interruption of less than 24 hours. The customer shall be credited for an interruption of 24 hours or more at the rate of 1/30 of

- (a) the monthly rates,
- (b) the assumed minutes of use charge, or
- (c) the minimum monthly usage charge, whichever is

applicable to the service involved for each period of 24 hours or major fraction (12 hours and 1 minute) thereof that the interruption continues. However, in the case of service billed based upon actual usage, no credit allowance will be given when the actual usage charge exceeds the minimum monthly usage charge in any one monthly billing period.

(4) The credit allowance(s) for an interruption or for a series of interruptions shall not exceed

- (a) the monthly rates,
- (b) the assumed minutes of use charge, or
- (c) the minimum monthly usage charge, whichever is

applicable for the service involved, for the service interrupted in any one monthly billing period.

(5) For certain Special Access Services (Digital Data Access, DA 1-4; and High Capacity, HC1), any period during which the error performance is below that specified for the service will be considered as an interruption.

(6) Service interruptions for Specialized Service or Arrangements provided under the provisions of Section 12. following shall be administered in the same manner as those set forth in this section (2.4.4) unless other regulations are specified with the individual case filing.

ACCESS SERVICE

2. General Regulations (Cont'd)

2.4 Payment Arrangements and Credit Allowances (Cont'd)

2.4.4 Credit Allowance for Service Interruptions (Cont'd)

(C) When Credit Allowance Does Not Apply

No credit allowance will be made for:

- (1) Interruptions caused by the negligence of the Customer.
 - (2) Interruptions of a service due to the failure of equipment or systems provided by the Customer or others.
 - (3) Interruptions of a service during any period in which the Telephone Company is not afforded access to the premises where the service is terminated.
 - (4) Interruptions of a service during the first 30 minute period when the Customer has released a service to the Telephone Company for maintenance purposes, to make rearrangements, or for the implementation of an order for a change in the service. Thereafter, a credit allowance as set forth in (B) preceding applies.
 - (5) Interruptions of a service which continue because of the failure of the Customer to authorize replacement of any element of Special Construction as set forth in the applicable Interstate Special Construction Tariff. The period for which no credit allowance is made begins on the seventh day after the Customer receives the Telephone Company's written notification of the need for such replacement and ends on the day after receipt by the Telephone Company of the Customer's written authorization for such replacement. (C)
(C)
 - (6) Periods when the Customer elects not to release the service for testing and/or repair and continues to use it on an impaired basis.
 - (7) An interruption or a group of interruptions, resulting from a common cause, for amounts less than one dollar.
-

ACCESS SERVICE

2. General Regulations (Cont'd)

2.4 Payment Arrangements and Credit Allowances (Cont'd)

2.4.4 Credit Allowance for Service Interruptions (Cont'd)

(D) Use of an Alternative Service Provided by the Telephone Company

Should the Customer elect to use an alternative service provided by the Telephone Company during the period that a service is interrupted, the Customer must pay the tariffed rates and charges for the alternative service used.

(E) Temporary Surrender of a Service

In certain instances, the Customer may be requested by the Telephone Company to surrender a service for purposes other than maintenance, testing or activity relating to a service order. If the Customer consents, a credit allowance will be granted. Customer consent for preemption is not required under conditions outlined in Section 13.3.2, following. The credit allowance will be 1/1440 of the monthly rate for each period of 30 minutes or fraction thereof that the service is surrendered. In no case will the credit allowance exceed the monthly rate for the service surrendered in any one monthly billing period.

ACCESS SERVICE

2. General Regulations (Cont'd)

2.4 Payment Arrangements and Credit Allowances (Cont'd)

2.4.5 Re-Establishment of Service Following Fire, Flood or Other Occurrence

(A) Nonrecurring Charges Do Not Apply

Charges do not apply for the re-establishment of service following a fire, flood or other occurrence attributed an Act of God provided that:

- (1) The service is of the same type as was provided prior to the fire, flood and other occurrence.
- (2) The service is for the same Customer.
- (3) The service is at the same location on the same premises.
- (4) The re-establishment of service begins within 60 days after Telephone Company service is available. (The 60 day period may be extended a reasonable period if the renovation of the original location on the premises affected is not practical within the allotted time period).

(B) Nonrecurring Charges Apply

Nonrecurring Charges apply for establishing service at a different location on the same premises or at a different premises pending re-establishment of service at the original location.

2.4.6 Title or Ownership Rights

(A) The payment of rates and charges by Customers for the services offered under the provisions of this Guide does not assign, confer or transfer title or ownership rights to proposals or facilities developed or utilized, respectively, by the Telephone Company in the provision of such services.

ACCESS SERVICE

2. General Regulations (Cont'd)

2.4 Payment Arrangements and Credit Allowances (Cont'd)

2.4.7 Ordering, Rating and Billing of Access Services where More than One Exchange Telephone Company Is Involved

The Telephone Company will handle ordering, rating and billing of Access Services under this Guide where more than one Exchange Telephone Company is involved in the provision of Access Service as set forth in (A) or (B) following, dependent on the interconnection arrangements between the Exchange Telephone Companies involved.

(A) For Access Service provided jointly with Ogden Telephone Company, the Telephone Company will accept the order for the Access Service from the customer.

(B) Meet Point Billing

For switched access services, Multiple Bill Meet Point Billing arrangements will apply. The multiple bill arrangements are subject to the provisions stipulated in the Multiple Exchange Carrier Access Billing Guidelines (MECAB) and the Multiple Exchange Carrier Ordering and Design Guidelines (MECOD) documents as referenced in the Commission's Memorandum and Order 86-104 released July 31, 1987. Separate bills will be rendered by each Exchange Telephone Company for access service, other than FGA and billing will be based upon the regulations, rates, and charges contained in its Access Service Tariff, subject to the following rules, as appropriate.

(1) For Access Service provided between Frontier Telephone of Rochester and the Dalton exchange of Citizens Telecom, the Shortsville exchange of Windstream Communications, or Frontier Communications of Seneca Gorham, Frontier Telephone of Rochester will accept the order for the Access Service from the Customer.

(2) For Access Service provided between Frontier Communications of New York and New York Telephone, or between Frontier Communications of Sylvan Lake and New York Telephone, New York Telephone will accept the order for Access Service from the customer.

ACCESS SERVICE

2. General Regulations (Cont'd)

2.4 Payment Arrangements and Credit Allowances (Cont'd)

2.4.7 Ordering, Rating and Billing of Access Services where More than One Exchange Telephone Company Is Involved (Cont'd)

(B) Meet Point Billing (Cont'd)

(3) For the service ordered as set forth in (1) and (2) preceding, the Exchange Telephone Company in whose territory the customer point of termination is located must also receive a copy of the order from the customer. In addition, when required by the Access Service tariff of the Exchange Telephone Company in whose operating territory the end office is located, the customer must also supply a copy of the order to that Exchange Telephone Company

(4) Each Exchange Telephone Company will provide its portion of the Transport element in its operating territory to an interconnection point (IP) with the other Exchange Telephone Company. Each Exchange Telephone Company will determine the charges involved for its portion of the Access Service ordered and will bill such charges in accordance with its Access Service tariff. The rate for the Transport Element for the Channel Mileage Element for Special Access will be determined as set forth in (8) following. All other charges in each Exchange Telephone Company tariff are applicable.

ACCESS SERVICE

2. General Regulations (Cont'd)

2.4 Payment Arrangements and Credit Allowances (Cont'd)

2.4.7 Ordering, Rating and Billing of Access Services where More than One Exchange Telephone Company Is Involved (Cont'd)

(B) Meet Point Billing (Cont'd)

(5) The Telephone Company will provide at least 30 days written notice to the customer prior to implementing any changes in the procedures for furnishing jointly provided access services.

When a Special Access Line used in connection with Switched Access is ordered and Channel Mileage applies (i.e., the WATS Serving Office and the end user customer end office are not coterminous) and one end of the Channel Mileage is in the Telephone Company operating territory and the other end is in another Exchange Telephone Company operating territory, the Exchange Telephone Company in whose operating territory the end office is located must receive the order from the customer. In addition, the Exchange Telephone Company in whose territory the WATS Serving Office is located must also receive a copy of the order from the customer. Each Exchange Telephone Company will provide the portion of the Channel Mileage element in its operating territory to an interconnection point (IP) with another Exchange Telephone Company and will bill the charges in accordance with its Access Service tariff. The rate for the Channel Mileage element will be determined as set forth in (8) following. All other appropriate charges in each Exchange Telephone Company tariff are applicable.

ACCESS SERVICE

2. General Regulations (Cont'd)

2.4 Payment Arrangements and Credit Allowances (Cont'd)

2.4.7 Ordering, Rating and Billing of Access Services where More than One Exchange Telephone Company Is Involved (Cont'd)

(B) Meet Point Billing (Cont'd)

(6) When a Special Access Service is ordered by a customer where one end of the Channel Mileage is in the Telephone Company operating territory and the other end is in another Exchange Telephone Company operating territory, except for Special Access Service provided with the use of Hubs, either of the Exchange Telephone Companies may receive the order from the customer. Each Exchange Telephone Company will provide the portion of the Channel Mileage element in its operating territory to an interconnection point (IP) with another Exchange Telephone Company and will bill the charges in accordance with its Access Service tariff. The rate for the Channel Mileage element will be determined as set forth in (8) following. All other appropriate charges in each Exchange Telephone Company tariff are applicable.

(7) When a Special Access Services involving a Hub is ordered by a customer where one end of the channel Mileage element is in an Exchange Telephone Company operating territory and the Hub is in another Exchange Telephone Company in whose territory the Hub is located must receive the order from the customer. In addition, the Exchange Telephone Companies in whose territory a customer premises is located must receive copies of the order from the customer. Each Exchange Telephone Company will provide the portion of the channel mileage element in its operating territory to an interconnection point (IP) with another Exchange Telephone Company and will bill the charges in accordance with its Access Service tariff. The rate for the Channel Mileage element will be determined as set forth in (8) following. All other appropriate charges in each Exchange Telephone Company tariff are applicable.

ACCESS SERVICE

2. General Regulations (Cont'd)

2.4 Payment Arrangements and Credit Allowances (Cont'd)

2.4.7 Ordering, Rating and Billing of Access Services where More than One Exchange Telephone Company Is Involved (Cont'd)

(B) Meet Point Billing (Cont'd)

(8) The rate for the local Transport or Channel Mileage element for services provided as set forth in (1) through (7) preceding is determined as follows:

(a) Determine the appropriate Local Transport or Channel mileage by computing the airline mileage between the two ends of the local Transport or Channel Mileage element. Determine the airline mileage for the local Transport element using the V & H method as set forth in National Exchange Carrier Tariff FCC No. 4. Determine the airline mileage for the Channel Mileage element using the V & H method as set forth in 7.4.5 following.

(b) Determine the rate for the airline mileage determined in (a) preceding using the Telephone Company's tariff. For each mileage sensitive rate element multiply such rate by the appropriate mileage and by the Telephone Company's billing percentage factor and divide by 100 to obtain the charges.

(c) Reserved

(d) Reserved

ACCESS SERVICE

2. General Regulations (Cont'd)

2.4 Payment Arrangements and Credit Allowances (Cont'd)

2.4.7 Ordering, Rating and Billing of Access Services where More than One Exchange Telephone Company Is Involved (Cont'd)

(B) Meet Point Billing (Cont'd)

(8) The rate for the local Transport or Channel Mileage element for services provided as set forth in (1) through (7) preceding is determined as follows: (Cont'd)

(e) Example 1: Originating Switched Access

(See Diagram 1)

- Feature Group D Switched Access is ordered to End Office.
- Originating End Office and Access Tandem are in the operating territory of a Telephone Company (TC-A).
- Customer Designated Premises is in the operating territory of a Telephone Company (TC-B)
- Assumptions:
 - TC-A Direct Trunk Transport BP = 40%
 - TC-B Direct Trunk Transport BP = 60%
 - Direct Trunked Transport mileage = 26 mi.
 - Tandem Switched Transport mileage = 23 mi.

Diagram 1

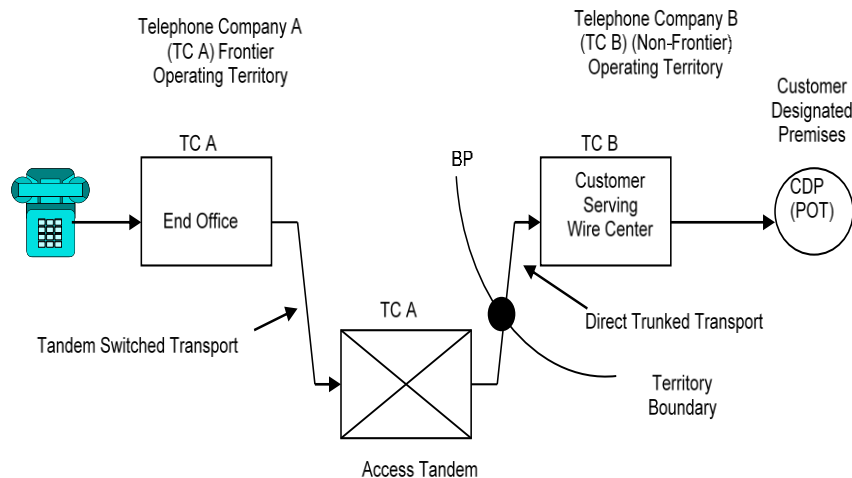

(3)

(N)

(N)

ACCESS SERVICE

2. General Regulations (Cont'd)

2.4 Payment Arrangements and Credit Allowances (Cont'd)

2.4.7 Ordering, Rating and Billing of Access Services where More than One Exchange Telephone Company Is Involved (Cont'd)

(B) Meet Point Billing (Cont'd)

(8) The rate for the local Transport or Channel Mileage element for services provided as set forth in (1) through (7) preceding is determined as follows: (Cont'd)

(e) Example 1: Originating Switched Access (Cont'd)
(See Diagram 1)

- Telephone Company A charges are:
 - End Office charges = 9,000 min. x EO rate
 - Tandem Switched Transport Facility charge = 9,000 min. x 23 mi. x TSF rate
 - Tandem Switched Transport Termination charge = 2 terminations x 9,000 min. x TST rate
 - Tandem Switching Rate = 9,000 min. x TS rate
 - Direct Trunked Facility charge = 26 mi. x DTF rate x 40%
 - Direct Trunked Termination charge = 1 termination x DTT rate
 - Shared Multiplexing charge = 9,000 min. x SM rate

Example 2: Terminating Switched Access – Tandem 3rd Party
(See Diagram 2A and 2B)

- Feature Group D Switched Access is ordered to End Office.
- Terminating Access Tandem is owned by Frontier Telephone ILEC Companies (TC-A) and End Office is owned by a non-Frontier Telephone Company (TC –B).
- Assumptions:
 - *TC-A Direct Trunk Transport BP = 40%
 - *TC-B Direct Trunk Transport BP = 60%
 - Direct Trunk Transport mileage = 26 mi.
 - TC-A Tandem Switched Transport BP = 20%
 - TC-B Tandem Switched Transport BP = 80%
 - Tandem Switched Transport mileage = 23 mi.

*Where applicable see Diagram 2A

(N)

(N)

ACCESS SERVICE

2. General Regulations (Cont'd)

2.4 Payment Arrangements and Credit Allowances (Cont'd)

2.4.7 Ordering, Rating and Billing of Access Services where More than One Exchange Telephone Company Is Involved (Cont'd)

(B) Meet Point Billing (Cont'd)

(8) The rate for the local Transport or Channel Mileage element for services provided as set forth in (1) through (7) preceding is determined as follows: (Cont'd)

(e) Example 2: Terminating Switched Access – Tandem 3rd Party (Cont'd)
(See Diagram 2A and 2B)

- Diagram 2A

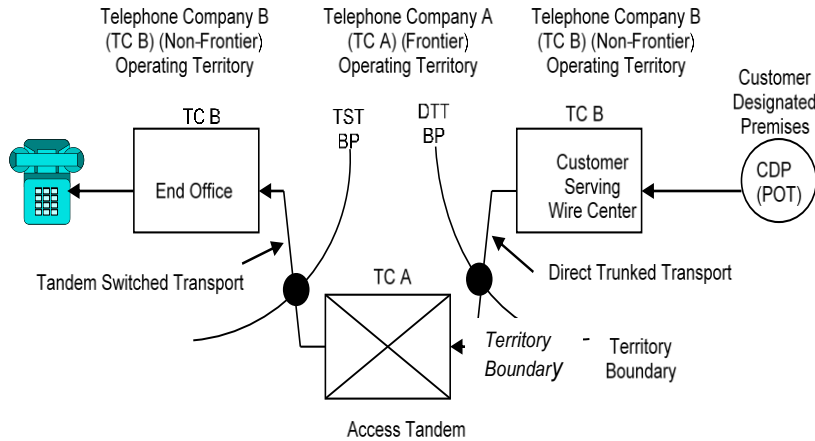

- Diagram 2B

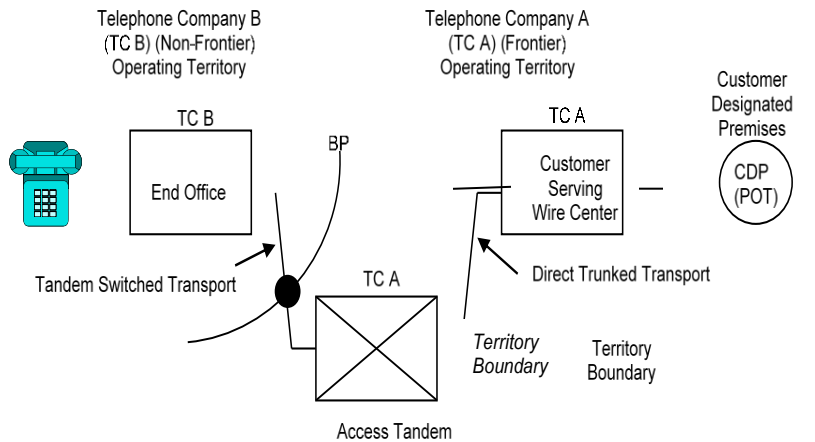

(3)

(N)

(N)

ACCESS SERVICE

2. General Regulations (Cont'd)

2.4 Payment Arrangements and Credit Allowances (Cont'd)

2.4.7 Ordering, Rating and Billing of Access Services where More than One Exchange Telephone Company Is Involved (Cont'd)

(B) Meet Point Billing (Cont'd)

(8) The rate for the local Transport or Channel Mileage element for services provided as set forth in (1) through (7) preceding is determined as follows: (Cont'd)

(e) Example 2: Terminating Switched Access – Tandem 3rd Party (Cont'd)
(See Diagram 2A and 2B)

- Telephone Company A charges are:
- Tandem Switched Transport Facility-3rd Party charge = 9,000 min. x 23 mi. x TSF-3rd Party rate x 20%
 - Tandem Switched Transport Termination-3rd Party charge = 1 termination x 9,000 min. x TST – 3rd Party rate
- Tandem Switching-3rd Party Rate = 9,000 min. x TS-3rd Party rate
 - Direct Trunked Facility charge
 - 2A = 26 miles. x DTF rate x 40%
 - 2B = 26 miles. x DTF rate
 - Direct Trunked Termination charge
 - 2A = 1 termination x DTT rate
 - 2B = 2 termination x DTT rate
 - Shared Multiplexing 3rd Party Charge = 9,000 min. x SM-3rd Party rate

(N)

(N)

ACCESS SERVICE

2. General Regulations (Cont'd)

2.4 Payment Arrangements and Credit Allowances (Cont'd)

2.4.7 Ordering, Rating and Billing of Access Services where More than One Exchange Telephone Company Is Involved (Cont'd)

(B) Meet Point Billing (Cont'd)

(8) The rate for the local Transport or Channel Mileage element for services provided as set forth in (1) through (7) preceding is determined as follows: (Cont'd)

(e) Example 3: Terminating Switched Access - Tandem End Office (See Diagram 3)

- Feature Group D Switched Access is ordered to End Office.
- Terminating End Office and Access Tandem are both owned by Frontier Telephone ILEC Companies (TC-A).
- Assumptions:
 - TC-A Direct Trunk Transport BP = 40%
 - TC-B Direct Trunk Transport BP = 60%
 - Direct Trunk Transport mileage = 26 mi.
 - Tandem Switched Transport mileage = 23 mi.

- Diagram 3

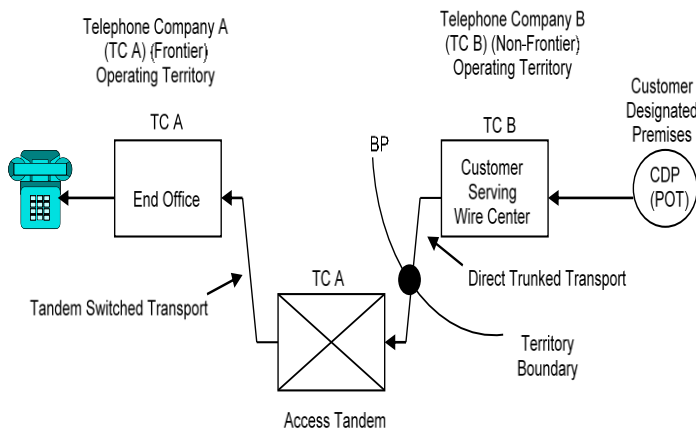

(N)

(N)

ACCESS SERVICE

2. General Regulations (Cont'd)

2.4 Payment Arrangements and Credit Allowances (Cont'd)

2.4.7 Ordering, Rating and Billing of Access Services where More than One Exchange Telephone Company Is Involved (Cont'd)

(B) Meet Point Billing (Cont'd)

(8) The rate for the local Transport or Channel Mileage element for services provided as set forth in (1) through (7) preceding is determined as follows: (Cont'd)

(e) Example 3 –Terminating Switched Access Tandem End Office (Cont'd)
(See Diagram 3)

- Telephone Company A charges are:
- End Office Charges = 9,000 min. x EO rate
 - Tandem Switched Facility – End Office charge
= 9,000 min. x 23 mi. x TSF-End Office rate.
- Tandem Switched Transport Termination –End Office charge
= 2 terminations x 9.000 min. x TST-End Office rate.
- Tandem Switching – End Office charge
= 9,000 min. x TS-End Office rate
- Direct Trunked Facility Charge
= 26 miles x DTF rate x 40%
- Direct Trunked Termination charge
= 1 termination x DTT rate
- Shared Multiplexing charge
= 9,000 min. x SM-End Office rate

(N)

(N)

ACCESS SERVICE

2. General Regulations (Cont'd)

2.4 Payment Arrangements and Credit Allowances (Cont'd)

2.4.7 Ordering, Rating and Billing of Access Services where More than One Exchange Telephone Company Is Involved (Cont'd)

(B) Meet Point Billing (Cont'd)

(8) The rate for the local Transport or Channel Mileage element for services provided as set forth in (1) through (7) preceding is determined as follows: (Cont'd)

(e) Example 4: Terminating Switched Access-Tandem 3rd Party
(See Diagram 4)

- Feature Group D Switched Access is ordered to End Office.
- End Office is owned by Frontier Telephone Company (TC-A).

Access Tandem is owned by a non-Frontier Telephone ILEC Company (TC-B).

Diagram 4

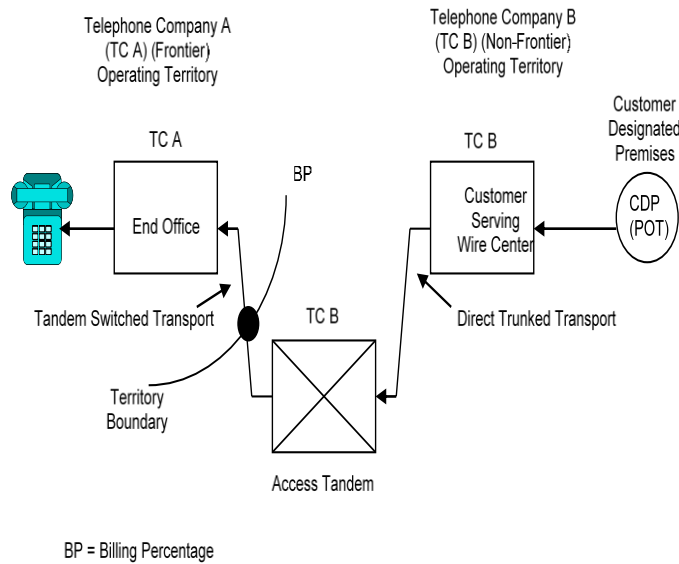

(N)

(N)

ACCESS SERVICE

2. General Regulations (Cont'd)

2.4 Payment Arrangements and Credit Allowances (Cont'd)

2.4.7 Ordering, Rating and Billing of Access Services where More than One Exchange Telephone Company Is Involved (Cont'd)

(B) Meet Point Billing (Cont'd)

(8) The rate for the local Transport or Channel Mileage element for services provided as set forth in (1) through (7) preceding is determined as follows: (Cont'd)

(e) Example 4: Terminating Switched Access-Tandem 3rd Party (Cont'd)
(See Diagram 4)

- Telephone Company A charges are:

- End Office charges = 9,000 min x EO rate

- Tandem Switched Facility -3rd Party charge
= 9,000 min. x 23 mi. x TSF-3rd Party rate x 80%

Tandem Switched Termination -3rd party charge
= 1 termination x 9,000 min. x TST-3rd Party rate

(N)

(N)

ACCESS SERVICE

2. General Regulations (Cont'd)

2.4 Payment Arrangements and Credit Allowances (Cont'd)

2.4.7 Ordering, Rating and Billing of Access Services where More than One Exchange Telephone Company Is Involved (Cont'd)

(B) Meet Point Billing (Cont'd)

(8) The rate for the local Transport or Channel Mileage element for services provided as set forth in (1) through (7) preceding is determined as follows: (Cont'd)

(e) Example 5: Originating Switched Access - Frontier Telephone ILEC Company owns only the End Office.

(See Diagram 5)

- Feature Group D Switched Access is ordered to End Office.
- End Office is owned by Frontier Telephone Companies (TC-A).

Access Tandem is owned by a non-Frontier Telephone ILEC Company (TC-B)

- Assumptions:
 - Direct Trunk Transport mileage = 26 mi.
 - TC-A Tandem Switched Transport BP = 80%
 - TC-B Tandem Switched Transport BP = 20%
 - Tandem Switched Transport mileage = 23 mi.

- Diagram 5

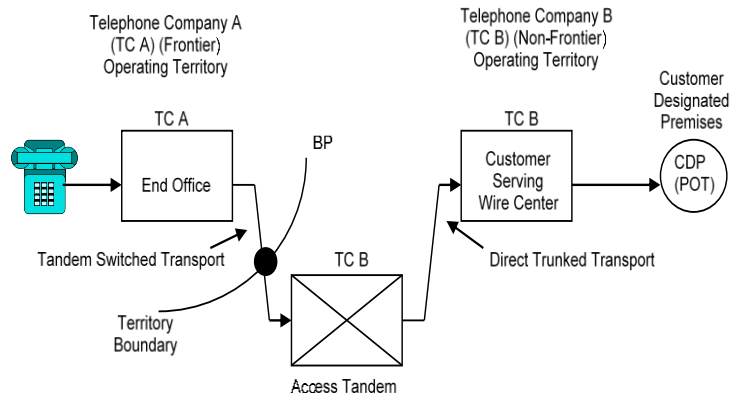

BP = Billing Percentage

(N)

(N)

ACCESS SERVICE

2. General Regulations (Cont'd)

2.4 Payment Arrangements and Credit Allowances (Cont'd)

2.4.7 Ordering, Rating and Billing of Access Services where More than One Exchange Telephone Company Is Involved (Cont'd)

(B) Meet Point Billing (Cont'd)

(8) The rate for the local Transport or Channel Mileage element for services provided as set forth in (1) through (7) preceding is determined as follows: (Cont'd)

(e) Example 5: Originating Switched Access - Frontier Telephone ILEC Company owns only the End Office. (Cont'd)
(See Diagram 5)

- Telephone Company A charges are:

- End Office charges = 9,000 min. x EO rate

- Tandem Switched Transport Facility charge
= 9,000 min. x 23 mi. x TSF rate x 80%.

- Tandem Switched Transport Termination charge = 1 termination x 9.000 min. x TST rate.

(N)

(N)

ACCESS SERVICE

2. General Regulations (Cont'd)

2.4 Payment Arrangements and Credit Allowances (Cont'd)

2.4.7 Ordering, Rating and Billing of Access Services where More than One Exchange Telephone Company Is Involved (Cont'd)

(B) Meet Point Billing (Cont'd)

(9) The interconnection points will be determined by the Exchange Telephone Companies involved. The billing percentage factor (BP) for Local Transport will be as set forth in the NATIONAL EXCHANGE CARRIER ASSOCIATION, INC. TARIFF FCC NO. 4.

(a) Reserved

(b) Reserved

(c) Reserved

(d) Entrance Facility and Direct End Office Transport charges will be billed on a meet-point basis according to the procedures outlined in Section 2.4.7(B)(5-8) preceding.

ACCESS SERVICE

2. General Regulations (Cont'd)

2.4 Payment Arrangements and Credit Allowances (Cont'd)

2.4.8 Reserved For Future Use (C)

ACCESS SERVICE

2. General Regulations (Cont'd)

2.4 Payment Arrangements and Credit Allowances (Cont'd)

2.4.9 Service Assurance Warranty Plan

(A) General

This section sets forth the terms and conditions under which credits for applicable monthly recurring charges for service outages for certain services will be issued. Credits provided hereunder represent an inclusive remedy, and are in lieu of all other remedies as described in Section 2.1.3 preceding.

(B) Services Subject to Credit

Monthly recurring charges, as set forth in Section 16 following, will be credited for a service outage on the following services:

- (1) DS1 High Capacity Service
- (2) DS3 High Capacity Service
- (3) DDS Digital Data Service

(C) Service Outage Credits

- (1) Ten percent of one month's recurring charge will be credited when an outage greater than one hour but less than two hours is experienced on a customer's DDS, DS1 or DS3 service.
- (2) Twenty-five percent of one month's recurring charges will be credited when an outage greater than two hours but less than four hours is experienced on a customer's DDS, DS1 or DS3 service.
- (3) Fifty percent of one month's recurring charges will be credited when an outage of greater than four hours is experienced on a customer's DDS, DS1 or DS3 service.

In no circumstance will the monthly credit be greater than one hundred percent of the monthly recurring charge.

(D) When Credit Allowances Do Not Apply

Credit for applicable recurring monthly charges for service outages will not apply when the outage is a result of civil disturbances, criminal actions, fire, flooding or other occurrences beyond the Telephone Company's control.

ACCESS SERVICE

2. General Regulations (Cont'd)

2.5 Connections

2.5.1 General

Equipment and Systems (i.e., terminal equipment, multiline terminating systems and communications systems) may be connected with Special Access Service furnished by the Telephone Company where such connection is made in accordance with the provisions specified in Technical Reference Publication AS No. 1 and in 2.1 preceding.

ACCESS SERVICE

2. General Regulations (Cont'd)

2.6 Definitions

Certain terms used herein are defined as follows:

ACCESS SERVICE

2. General Regulations (Cont'd)

2.6 Definitions (Cont'd)

Communications System

The term "Communications System" denotes channels and other facilities which are capable of communications between terminal equipment provided by other than the Telephone Company.

Competitive County

The term "Competitive County" denotes the geographic unit of a county or county-equivalent that passes or has passed a competitive market test specified by the FCC. Competitive County also denotes a county or county-equivalent that failed a competitive market test specified by the FCC, but was granted Phase II, Level 2 pricing flexibility prior to June 1, 2017.

(N)

Connecting Facility Assignment

The term "Connecting Facility Assignment or (CFA)" denotes the identification of a channel or circuit to be used from a high capacity facility.

(N)

Conventional Signaling

The inter-machine signaling system which has been traditionally used in North America for the purpose of transmitting the called number's address digits from the originating end office to the switching machine which will terminate the call. In this system, all of the dialed digits are received by the originating switching machine, a path is selected, and the sequence of supervisory signals and outpulsed digits is initiated. No overlap outpulsing, ten-digit ANI, ANI information digits, or acknowledgement wink are included in this signaling sequence.

Corridor Service

The term "Corridor Service" applies to the exceptions to the MFJ Decree that allow the Telephone Company to provide interstate interLATA services in certain designated areas.

Customer(s)

The term "Customer(s)" denotes any individual, partnership, association, joint-stock company, trust, corporation, or governmental entity or other entity which subscribes to the services or other arrangements offered under this Guide, including both Interexchange Carriers (ICs) and End users.

ACCESS SERVICE

2. General Regulations (Cont'd)

2.6 Definitions (Cont'd)

Call

The term "Call" denotes a Customer attempt for which the complete address code (e.g., 0-, 911, or 10 digits) is provided to the serving dial tone office.

Carrier or Common Carrier

See Interexchange Carrier.

CCS

The term "CCS" denotes a hundred call seconds, which is a standard unit of traffic load that is equal to 100 seconds of usage or capacity of a group of servers (e.g., trunks).

Central Office

The term "Central Office" denotes a local Telephone Company switching system where Telephone Exchange Service customer station loops are terminated for purposes of interconnection to each other and to trunks.

Central Office Prefix

The term "Central Office Prefix" denotes the first three digits (NXX) of the seven digit telephone number assigned to a Customer's Telephone Exchange Service when dialed on a local basis.

Centralized Automatic Reporting on Trunks (CAROT) Testing

The term "Centralized Automatic Reporting on Trunks (CAROT) Testing" denotes a type of testing which includes the capacity for measuring operational and transmission parameters.

Channel(s)

The term "Channel(s)" denotes an electrical or photonic, in the case of fiber optic based transmission systems, communications path between two or more points of termination.

ACCESS SERVICE

2. General Regulations (Cont'd)

2.6 Definitions (Cont'd)

Channel Service Unit

The term "Channel Service Unit" denotes equipment which performs one or more of the following functions: termination of a digital facility, regeneration of digital signals, detection and/or correction of signal format errors, remote loop back.

Channelize

The term "Channelize" denotes the process of multiplexing-demultiplexing wider bandwidth or high speed channels into narrower band-width or lower speed channels.

Clear Channel Capability

The term "Clear Channel Capability" denotes an arrangement that allows the customer to transport 1.544 Mbps of information through a DS1 with no constraint on the quantity or sequence of one (mark) and zero (space) bits. This service utilizes the Bipolar with eight zero substitution (B8ZS) method of providing bit sequence independence. This arrangement is capable of transporting DS1 signals which utilize Extended Superframe Format (ESF).

C-Message Noise

The term "C-Message Noise" denotes the frequency weighted average noise within an idle voice channel. The frequency weighting, called C-message, is used to simulate the frequency characteristic of the 500-type telephone set and the hearing of the average subscriber.

C-Notched Noise

The term "C-Notched Noise" denotes the C-message frequency weighted noise on a voice channel with a holding tone, which is removed at the measuring end through a notch (very narrow band) filter.

Coin Station

The term "Coin Station" denotes a location where Telephone Company equipment is provided in a public or semipublic place where Telephone Company customers can originate telephonic communications and pay the applicable charges by inserting coins into the equipment.

ACCESS SERVICE

2. General Regulations (Cont'd)

2.6 Definitions (Cont'd)

Commingling

The term "Commingling" means the connecting, attaching, or otherwise linking of an unbundled network element (UNE), or a combination of unbundled network elements (UNEs), to one or more facilities or services that a requesting telecommunications carrier has obtained at wholesale from an incumbent LEC, or the combining of an UNE, or a combination of UNEs, with one or more such facilities or services.

Common Line

The term "Common Line" denotes a line, trunk, pay telephone line or other facility provided under the local exchange service tariffs of the Telephone Company, terminated on a central office switch. A common line-residence is a line or trunk provided under the residence regulations of the local exchange service tariffs. A common line-business is a line provided under the business regulations of the local exchange service tariffs.

Common Channel Signaling (CCS)

The term "Common Channel Signaling" denotes a Digital Switched Communications Network that allows call control messages from the voice and data networks to be transferred on separate communications paths (out of band) from the voice and data communications.

Common Channel Signaling Network (CCSN)

The term "Common Channel Signaling Network" denotes the digital data network carrying signaling information that interfaces with Telephone Company voice/data network for services using CCS7 Signaling protocol.

Common Channel Signaling Network Connection (CCSNC)

The term "Common Channel Signaling Network Connection" denotes the connection between the customer's Signaling Point Of Interface (SPOI) and the Telephone Companies Signal Transfer Point (STP) for the transport of signaling information.

Communications System

The term "Communications System" denotes channels and other facilities which are capable of communications between terminal equipment provided by other than the Telephone Company.

Competitive County

The term "Competitive County" denotes that the geographic unit of a county or county-equivalent that passes or has passed a competitive market test specified by the FCC. Competitive County also denotes a county or county-equivalent that failed a competitive market test specified by the FCC, but was granted Phase II, Level 2 pricing flexibility prior to June 1, 2017

ACCESS SERVICE

2. General Regulations (Cont'd)

2.6 Definitions (Cont'd)

Confirmed Service Date

The term "Confirmed Service Date" denotes the date on which work activity is scheduled to be completed by the Telephone Company and the service is ready for use by the customer. The Confirmed Service Date is provided by the Telephone Company to the customer.

Customer

The term "Customer" denotes any individual, partnership, association, corporation, or governmental agency or any other entity which subscribes to the services offered under this Guide including both Interexchange Carriers (Customers) and End Users.

Customer Designated Premises

The term "Customer Designated Premises" denotes the premises specified by the customer for the termination of Access Services.

Customer Message

The term "Customer Message" used herein for Feature Group A Switched Access Service denotes a completed call over an interstate Feature Group A Switched Access Service. A completed call includes both completed calls originated to and terminated from a Feature Group A Switched Access Service. A customer message begins in the originating direction when the off-hook supervision provided by the premise of the ordering customer is received by Telephone Company recording equipment.

A customer message begins in the terminating direction when answer supervision is received by Telephone Company recording equipment indicating the called party has answered. A customer message ends in the originating direction when disconnect supervision is received by Telephone Company recording equipment from the premise of the ordering customer. A customer message ends in the terminating direction when disconnect supervision is received by Telephone Company recording equipment from either the premise of the ordering customer or the called party.

The term "Customer Message" used herein for Feature Group C and D Switched Access Service denotes a completed interstate call originated by a customer's end user. A customer message begins when answer supervision from the premise of the ordering customer is received by Telephone Company recording equipment indicating that the called party has answered. A message ends when disconnect supervision is received by Telephone Company recording equipment from either the premise of the ordering customer or the customer's end user premise from which the call originated.

ACCESS SERVICE

2. General Regulations (Cont'd)

2.6 Definitions (Cont'd)

Data Transmission (107 Type) Test Line

The term "Data Transmission (107 Type) Test Line" denotes an arrangement which provides for a connection to a signal source which provides test signals for one-way testing of data and voice transmission parameters.

Decibel (db)

The term "Decibel" denotes a unit used to express relative difference in power, usually between acoustic or electric signals, equal to ten (10) times the common logarithm or the ratio of two signal powers.

Decibel Reference Noise C-Message Weighting

The term "Decibel Reference Noise C-Message Weighting" denotes noise power measurements with C-Message weighting in decibels relative to a reference 1000 Hz tone of 90 dB below 1 milliwatt.

Decibel Reference Noise C-Message Referenced to 0

The term "Decibel Reference Noise C-Message Referenced to 0" denotes noise power in "Decibel Reference Noise C-Message Weighting" referred to or measured at a zero transmission level point.

Detail Billing

The term "Detail Billing" denotes the listing of each message and/or rate element for which charges to a Customer are due on a bill prepared by the Telephone Company.

Digital Access Cross-connect System

The term Digital Access Cross-connect System denotes a multiplexing system that provides a digital interface between a Telephone Company designated Hub wire center and a customer designated premises.

ACCESS SERVICE

2. General Regulations (Cont'd)

2.6 Definitions (Cont'd)

Digital Data Service Secondary Channel

The term "Digital Data Service Secondary Channel" denotes an option to DDS that allows the performance of network testing and management through a derived data channel at a substantially lower bit rate without network interruption.

Direct-Trunked Transport

The term "Direct-Trunked Transport" denotes transport from the serving wire center to the end office without switching at the tandem.

Discontinuance Non-Recurring Charge

(C)

In addition to any other charges associated with discontinuance of services, the Telephone Company will charge a discontinuance non-recurring charge to disconnect services. This charge applies on a per circuit basis as listed in Section 16.

(C)

Directory Assistance (Interstate)

The term "Directory Assistance" denotes the provision of telephone numbers by a Telephone Company operator when the operator location is accessed by a Customer by dialing (NPA) 555-1212.

Dual Tone Multifrequency Address Signaling

The term "Dual Tone Multifrequency Address Signaling" denotes a type of signaling that is an optional feature of Switched Access Feature Group A. It may be utilized when Feature Group A is being used in the terminating direction (from the point of termination with the Customer to the local exchange end office). An office arranged for Dual Tone Multifrequency Signaling would expect to receive address signals from the Customer in the form of Dual Tone Multifrequency signals.

Echo Control

The term "Echo Control" denotes the control of reflected signals in a telephone transmission patch.

Echo Path Loss (EPL)

The term "Echo Path Loss" denotes the measure of reflected signal at a 4-wire point of interface without regard to the send and receive Transmission level Point (TLP).

Echo Return Loss (ERL)

The term "Echo return Loss" denotes a frequency weighted measure of return loss over the middle of the voiceband (approximately 500 to 2500 Hz), where talker echo is most annoying.

ACCESS SERVICE

2. General Regulations (Cont'd)

2.6 Definitions (Cont'd)

Effective 2-Wire

The term "Effective 2-Wire" denotes a condition which permits the simultaneous transmission in both directions over a channel, but it is not possible to insure independent information transmission in both directions. Effective 2-wire channels may be terminated with 2-wire and 4-wire interfaces.

Effective 4-Wire

The term "Effective 4-Wire" denotes a condition which permits the simultaneous independent transmission of information in both directions over a channel. The method of implementing effective 4-wire transmission is at the discretion of the Telephone Company (physical, time domain, frequency-domain separation or echo cancellation techniques). Effective 4-wire channels may be terminated with a 2-wire interface at the Customer's premises. However, when terminated 2-wire, simultaneous independent transmission cannot be supported because the two-wire interface combines the transmission paths into a single path.

End Office Switch

The term "End Office Switch" denotes a local Telephone Company switching system where Telephone Exchange Service customer station loops are terminated for purposes of interconnection to each other and to trunks. Included are Remote Switching modules (RSM) and Remote Switching Systems (RSS) served by a host office in a different wire center.

End User

The term "End User" means any customer of an interstate or foreign telecommunications service that is not a carrier, except that a carrier other than a telephone company shall be deemed to be an "end user" when such carrier uses a telecommunications service for administrative purposes, and a person or entity that offers telecommunications service exclusively as a reseller shall be deemed to be an "end user" if all resale transmissions offered by such reseller originate on the premises of such reseller.

ACCESS SERVICE

2. General Regulations (Cont'd)

2.6 Definitions (Cont'd)

Entrance Facility

The term "Entrance Facility" denotes a Switched Access Service dedicated Local Transport facility between the customer's serving wire center and the customer's premise.

Entry Switch

See First Point of Switching

Envelope Delay Distortion (EDD)

The term "Envelope Delay Distortion" denotes a measure of the linearity of the phase versus frequency of a channel.

Equal Level Echo Path Loss (ELEPL)

The term "Equal Level Echo Path Loss" denotes the measure of Echo Path Loss (EPL) at a 4-wire interface which is corrected by the difference between the send receive and receive Transmission Level Point (TLP).

[ELEPL - EPL = TLP (send) + TLP (receive)].

Expected Measured Loss (EML)

The term "Expected Measured Loss" denotes a calculated loss which specifies the end-to-end 1000-Hz transducer loss on a terminated test connection between two readily accessible manual or remote test points. It is the sum of the inserted connection loss including any test pads.

Exchange

The term "Exchange" denotes a unit generally smaller than a LATA, established by the Telephone Company for the administration of communications service in a specified area which usually embraces a city, town or village and its environs. It consists of one or more central offices together with the associated facilities used in furnishing communications service within that area. One or more designated exchanges comprise a given LATA.

ACCESS SERVICE

2. General Regulations (Cont'd)

2.6 Definitions (Cont'd)

Field Identifier

The term "Field Identifier" denotes two to four alphabetic characters or a combination of one to three alphabetic characters and one numeric character. The numeric character must always be the last character of the Field Identifier. Field identifiers are used on service orders to identify an associated data entry and to convey specific instructions. Field Identifiers may or may not have associated data. Selected field identifiers are used in Telephone Company billing systems to generate nonrecurring charges.

First Come - First Served

The term "First Come - First Served" denotes a procedure followed when a shortage of facilities or equipment occurs, such that an Access Service ordered cannot be installed. The orders delayed by the shortage of facilities will be prioritized according to the sequence in which they were received. That is, when facilities or equipment become available, the first order received will be the first order processed.

First Point of Switching

The term "First Point of Switching" denotes the first Telephone Company location at which switching occurs on the terminating path of a call proceeding from the Customer premises to the terminating end office and, at the same time, the last Telephone Company location at which switching occurs on the originating path of a call proceeding from the originating end office to the Customer premises.

Frequency Shift

The term "Frequency Shift" denotes the change in the frequency of a tone as it is transmitted over a channel.

Grandfathered

The term "Grandfathered" denotes Terminal Equipment, Multiline Terminating Systems and Protective Circuitry directly connected to the facilities utilized to provide services under the provisions of this Guide, and which are considered grandfathered under Part 68 of the F.C.C.'s Rules and Regulations.

ACCESS SERVICE

2. General Regulations (Cont'd)

2.6 Definitions (Cont'd)

Host Office

The term "Host Office" denotes an electronic switching system which provides call processing capabilities for one or more Remote Switching Modules or Remote Switching Systems.

IC CDL

The Term "IC CDL" denotes a Customer Designated Location (CDL) where facilities for interstate access is terminated and connected to an Interexchange Carrier. (N)

Immediately Available Funds

The term "Immediately Available Funds" denotes a corporate or personal check drawn on a bank account and funds which are available for use by the receiving party on the same day on which they are received and include U.S. Federal Reserve bank wire transfers, U.S. Federal Reserve notes (paper cash), U.S. coins, U.S. Postal Money Orders and New York Certificates of Deposit.

Impedance Balance

The term "Impedance Balance" denotes the method of expressing Echo Return Loss and Singing Return Loss at a 4-wire interface whereby the gains and/or loss of the 4 wire portion of the transmission path, including the hybrid, are not included in the specification.

Impulse Noise

The term "Impulse Noise" denotes any momentary occurrence of the noise on a channel over a specified level threshold. It is evaluated by counting the number of occurrences which exceed the threshold.

Individual Case Basis (ICB)

The term "Individual Case Basis" denotes a condition in which the regulations, if applicable, rates and charges for an offering under the provisions of this Guide are developed based on the circumstances in each case.

ACCESS SERVICE

2. General Regulations (Cont'd)

2.6 Definitions (Cont'd)

Inserted Connection Loss (ICL)

The term "Inserted Connection Loss" denotes the 1004 Hz power difference (in dB) between the maximum power available at the originating end and the actual power reaching the terminating end through the inserted connection.

Integrated Services Digital Network (ISDN)

The term "ISDN" refers to Integrated Services Digital Network as defined in the Telephone Company's local exchange or general exchange tariffs. ISDN comes in two varieties. Basic Rate Interface (BRI) ISDN consists of two circuit-switched 64 Kbps channels and one packet-switched 16 Kbps channel. Primary Rate Interface (PRI) ISDN consists of 23 circuit-switched 64 Kbps channels and one packet-switched 64 Kbps channel. With either BRI ISDN or PRI ISDN, a circuit-switched 64 Kbps channel may be used for voice transmission or data transmission, depending on the customer's needs and equipment.

Interexchange Carrier (IC) or Interexchange Common Carrier

The term "Interexchange Carrier" (Customer) or "Interexchange Common Carrier" denotes any individual, partnership, association, joint-stock company, trust, governmental entity or corporation engaged for hire in interstate or foreign communication by wire or radio, between two or more exchanges.

Intermodulation Distortion

The term "Intermodulation Distortion" denotes a measure of the nonlinearity of a channel. It is measured using four tones, and evaluating the ratios (in dB) of the transmitted composite four-tone signal power to the second-order products of the tones (R2), and the third-order products of the tones (R3).

Interstate Communications

The term "Interstate Communications" denotes both interstate and foreign communications.

Intrastate Communications

The term "Intrastate Communications" denotes any communications within a state subject to oversight by a state regulatory commission as provided by the laws of the state involved.

ACCESS SERVICE

2. General Regulations (Cont'd)

2.6 Definitions (Cont'd)

Network Interface Device

The term "Network Interface Device" denotes any Company provided means of interconnection of end user customer premises wiring to the Local Exchange Carrier's distribution plant, such as a cross connect device used for that purpose.

Non-Standard Premises

The term "Non-Standard Premises", NSP, denotes a free-standing structure, e.g., a billboard, a communication, electrical or water tower, etc., which is used for an antenna site. See also Premises.

Nonsynchronous Test Line

The term "Nonsynchronous Test Line" denotes an arrangement in step-by-step end offices which provides operational tests which are not as complete as those provided by the synchronous test lines, but can be made more rapidly.

North American Numbering Plan

The term "North American Numbering Plan" denotes a three-digit area (Numbering Plan Area) code and a seven-digit telephone number made up of a three-digit Central Office code plus a four-digit station number.

Off-Hook

The term "Off-hook" denotes the active condition of Switched Access or a Telephone Exchange Service line.

On-hook

The term "On-hook" denotes the idle condition of Switched Access or a Telephone Exchange Service line.

Open Circuit Test Line

The term "Open Circuit Test Line" denotes an arrangement in an end office which provides an ac open circuit termination of a trunk or line by means of an inductor of several Henries.

ACCESS SERVICE

2. General Regulations (Cont'd)

2.6 Definitions (Cont'd)

Loop Around Test Line

The term "Loop Around Test Line" denotes an arrangement utilizing a telephone company central office to provide a means to make certain two-way transmission tests on a manual basis. This arrangement has two central office terminations, each reached by means of separate telephone numbers and does not require any specific customer premises equipment. Equipment subject to this test arrangement is at the discretion of the customer.

Loss Deviation

The term "Loss Deviation" denotes the variation of the actual loss from the designed value.

Message

The term "Message" denotes a completed call.

Milliwatt (102 Type) Test Line

The term "Milliwatt (102 Type) Test Line" denotes an arrangement in an end office which provides a 1004 Hz tone at 0 dBm0 for one-way transmission measurements towards the Customer's premises from the Telephone Company end office.

Network Control Signaling

The term "Network Control Signaling" denotes the transmission of signals used in the telecommunications system which perform functions such as supervision (control, status, and charge signals), address signaling (e.g., dialing), calling and called number identifications, rate of flow, service selection error control and audible tone signals (call progress signals indicating re-order or busy conditions, alerting, coin denominations, coin collect and coin return tones) to control the operation of the telecommunications system.

ACCESS SERVICE

2. General Regulations (Cont'd)

2.6 Definitions (Cont'd)

Nonsynchronous Test Line

The term "Nonsynchronous Test Line" denotes an arrangement in step-by-step end offices which provides operational tests which are not as complete as those provided by the synchronous test lines, but can be made more rapidly.

North American Numbering Plan

The term "North American Numbering Plan" denotes a three-digit area or Numbering Plan Area (NPA) code and a seven-digit telephone number made up of a three-digit Central Office code plus a four-digit station number.

Off-hook

The term "Off-hook" denotes the active condition of Switched Access or a Telephone Exchange Service line.

On-hook

The term "On-hook" denotes the idle condition of Switched Access or a Telephone Exchange Service line.

Open Circuit Test Line

The term "Open Circuit Test Line" denotes an arrangement in an end office which provides an ac open circuit termination of a trunk or line by means of an inductor of several Henries.

Originating Direction

The term "Originating Direction" denotes the use of access service for the origination of calls from an End User premises to an IC premises.

Other Network Provider

The term "Other Network Provider", or "ONP" refers to an entity that constructs or acquires its own switching, transmission, or other telecommunications facilities for the purpose of providing local and intrastate telecommunications services for themselves or others.

ACCESS SERVICE

2. General Regulations (Cont'd)

2.6 Definitions (Cont'd)

Pay Telephone

The term "Pay Telephone" denotes Telephone Company provided instruments and related facilities that are available to the general public for public convenience and necessity, including public and semipublic telephones, and coinless telephones.

Permanent Virtual Circuit (PVC)

The term "Permanent Virtual Circuit", or "PVC", denotes a virtual circuit that provides the equivalent of a dedicated private line service

Phase Jitter

The term "Phase Jitter" denotes the unwanted phase variations of a signal.

Point of Termination

The term "Point of Termination" denotes the point of demarcation within a customer-designated premises at which the Telephone Company's responsibility for the provision of access service ends.

Premises

The term "Premises" denotes a building or buildings (except railroad right of way, etc.) not separated by a public highway.

Presubscribed Interexchange Carrier Charge (PICC)

PICC is a monthly charge expressed in dollars and cents per line which is to recover the common line revenues permitted under price cap rules in FCC Part 61. The PICC is assessed on a per End User line basis to each End User's interLATA presubscribed carrier. If an End User does not have a presubscribed interexchange carrier, the PICC rate is assessed directly to the End User.

ACCESS SERVICE

2. General Regulations (Cont'd)

2.6 Definitions (Cont'd)

Primary Local Carrier

See "Local Carrier Customer"

Primary Rate Interface (PRI or PRI ISDN)

See Integrated Services Digital Network

Remote Switching Modules (RSM) and/or Remote Switching Systems (RSS)

The term "Remote Switching Modules and/or Remote Switching Systems" denotes small, remotely controlled electronic end office switches which obtain their call processing capability from an ESS type Host Office. The RSM/RSS cannot accommodate direct trunks to a Customer.

Return Loss

The term "Return Loss" denotes a measure of the similarity between the two impedances at the junction of two transmission paths. The higher the return loss, the higher the similarity.

Registered Equipment

The term "Registered Equipment" denotes the Customer's premises equipment which complies with and has been approved within the Registration Provisions of Part 68 of the F.C.C.'s Rules and Regulations.

Serving Wire Center

The term "Serving Wire Center" denotes the wire center from which the customer designated premises would normally obtain dial tone from the Telephone Company.

Seven Digit Manual Test Line

The term "Seven Digit Manual Test Line" denotes an arrangement which allows the Customer to select balance, milliwatt and synchronous test lines by manually dialing a seven digit number over the associated access connection.

ACCESS SERVICE

2. General Regulations (Cont'd)

2.6 Definitions (Cont'd)

Shortage of Facilities or Equipment

The term "Shortage of Facilities or Equipment" denotes a condition which occurs when the Telephone Company does not have appropriate cable, switching capacity, bridging or, multiplexing equipment, etc., necessary to provide the Access Service requested by the customer.

Short Circuit Test Line

The term "Short Circuit Test Line" denotes an arrangement in an end office which provides for an ac short circuit termination of a trunk or line by means of a capacitor of at least four microfarads.

Signal-to-C-Notched Noise Ratio

The term "Signal-to-C-Notched Noise Ratio" denotes the ratio in dB of a test signal to the corresponding C-Notched Noise.

Signaling Point Of Interface (SPOI)

The term "Signaling Point Of Interface" (SPOI) denotes the interface point between the Telephone Company and its Access customers for purposes of exchanging SS7 Signaling messages for CCS services.

Signaling System Seven (SS7)

The term "Signaling System Seven" (SS7) denotes the layered protocol used for standardized Common Channel Signaling in the United States.

Signaling Transfer Point (STP)

The term "Signaling Transfer Point" (STP) denotes a packet switch providing CCS Network Access and performs CCS message routing and screening.

ACCESS SERVICE

2. General Regulations (Cont'd)

2.6 Definitions (Cont'd)

Transmission Measuring (105 Type) Test Line/Responder

The term "Transmission Measuring (105 Type) Test Line/Responder" denotes an arrangement in an end office which provides far-end access to a responder and permits two-way loss and noise measurements to be made on trunks from a near end office.

Transmission Path

The term "Transmission Path" denotes an electrical path capable of transmitting signals within the range of the service offering, e.g., a voice grade transmission path is capable of transmitting voice frequencies within the approximate range of 300 to 3000 Hz. A transmission path is comprised of physical or derived facilities consisting of any form or configuration of plant typically used in the telecommunications industry.

Trunk

The term "Trunk" denotes a communications path connecting two switching systems in a network, used in the establishment of an end-to-end connection.

Trunk Group

The term "Trunk Group" denotes a set of trunks which are traffic engineered as a unit for the establishment of connections between switching systems in which all of the communications paths are interchangeable.

Trunk-Side Connection

The term "Trunk-Side Connection" denotes the connection of a transmission path to the trunk side of a local exchange switching system.

Two-Wire to Four-Wire Conversion

The term "Two-Wire to Four-Wire Conversion" denotes an arrangement which converts a four-wire transmission path to a two-wire transmission path to allow a four-wire facility to terminate in a two-wire entity (e.g., central office switch).

ACCESS SERVICE

2. General Regulations (Cont'd)

2.6 Definitions (Cont'd)

Unbundled Network Elements (UNEs)

The term "Unbundled Network Elements" denotes the physical facilities of the network, including the associated features, functions and capabilities, that are capable of being used in the provision of a telecommunications service, made available pursuant to Section 251 of the Telecommunications Act of 1996.

Uniform Service Order Code (USOC)

The term "Uniform Service Order Code" denotes a three or five character alphabetic, numeric, or a alphanumeric code that identifies a specific item of service or equipment. Uniform Service Order Codes are used in the Telephone Company billing system to generate recurring rates and nonrecurring charges.

V and H Coordinates Method

The term "V and H Coordinates Method" denotes a method of computing airline miles between two points by utilizing an established formula which is based on the vertical (V) and horizontal (H) coordinates of the two points.

WATS Serving Office

The term "WATS Serving Office" denotes a Telephone company designated serving wire center where switching, screening and/or recording functions are performed in conjunction with the provision of special access services.

Wire Center

The term "Wire Center" denotes a building in which one or more central offices, used for the provision of Telephone Exchange Services, are located.

ACCESS SERVICE

3. RESERVED FOR FUTURE USE

ACCESS SERVICE

4. RESERVED FOR FUTURE USE

ACCESS SERVICE

5. Ordering Options for Special Access Service

5.1 General

This section sets forth the regulations and charges for Access Orders for Special Access Services. These charges are in addition to other applicable charges as set forth in other sections of this Guide.

An Access Order is an order to provide the Customer with Special Access Service or to provide changes to existing services.

The regulations, rates, and charges for Special Construction as set forth in the applicable Interstate Special Construction Tariff are in addition to the regulations, rates, and charges specified in this section.

Special Construction is not applicable to Expanded Interconnection Service.

5.1.1 Ordering Conditions

A Customer may order any number of services of the same type and between the same premises on a single Access Order. All details for services for a particular order must be identical except for those for multipoint service.

The Customer shall supply all information necessary for the Telephone Company to provide and bill for the requested service.

In addition to the order information required in 5.2 following, the customer must also provide:

- Customer name and address (es)
- Billing name and address (when different from customer name and address)
- Customer's end user premises address
- Customer contact name(s) and telephone number(s) for the following provisioning activities: order negotiation, order confirmation, interactive design, installation and billing.

(N)
|
|
|
(N)

ACCESS SERVICE

- 5. Ordering Options for Switched and Special Access Service (Cont'd)
- 5.1 General (Cont'd)
- 5.1.1 Ordering Conditions (Cont'd)

ACCESS SERVICE

5. Ordering Options for Switched and Special Access Service (Cont'd)

5.1 General (Cont'd)

5.1.2 Provision of Other Services

(A) Testing Service, Additional Engineering, Additional Labor, Restoration Priority and Special Facilities Routing shall be ordered with an Access Order or subsequently as set forth in (B) following. The rates and charges for these services, as set forth in other sections of this Guide, will apply in addition to the ordering charges set forth in this section and the rates and charges for the Access Service with which they are associated.

(B) With the agreement of the Telephone Company, the items listed in (A) preceding may subsequently be added to the order at any time, up to and including the service date for the Access Service. When added subsequently, charges for a design change set forth in 5.2.2 (C) following will apply when an engineering review is required.

(C) Additional Engineering is not an ordering option, but will be applied to an Access Order when the Telephone Company determines Additional Engineering is necessary to accommodate a customer request. Additional Engineering will only be required as set forth in Section 13.1 following. When it is required, the customer will be so notified and will be furnished with a written statement setting forth the justification for the Additional Engineering as well as an estimate of the charges. If the customer agrees to the Additional Engineering, a firm order will be established. If the customer does not want the service or facilities after being notified that Additional Engineering of Telephone Company facilities is required, the order will be withdrawn and no charges will apply. Once a firm order has been established, the total charge to the customer for the Additional Engineering may not exceed the estimated amount by more than 10%.

The regulations, rates and charges for Additional Engineering are as set forth in Section 13.1 following and are in addition to the regulations, rates and charges specified in this section.

ACCESS SERVICE

5. Ordering Options for Switched and Special Access Service (Cont'd)

5.2 Access Order

An Access Order is used by the Telephone Company to provide to a Customer Access Service as follows:

- - Special Access Services as described in Section 7. following
-

ACCESS SERVICE

- 5. Ordering Options for Switched and Special Access Service (Cont'd)
- 5.2 Access Order (Cont'd)

ACCESS SERVICE

5. Ordering Options for Switched and Special Access Service (Cont'd)

5.2 Access Order (Cont'd)

For all Special Access Services, the customer must specify the "customer designated premises" or Hubs involved, the type of service (e.g., Metallic, Telegraph Grade, Voice Grade, High Capacity, etc.), the channel interface, technical specification package and options desired. For multipoint services, the channel interface at each premises may, at the request of the customer, be different but all such interfaces shall be compatible.

Where the Special Access Service is exempt from the Special Access Surcharge, as set forth in Section 16 following, the customer shall furnish with the order the certification as described in Section 7.4.2 following.

Orders for Special Access Service are subject to service connection charges. For certain kinds of Special Access Service additional charges apply as described in Section 7 following. Access Order charges will be waived under conditions outlined in below.

ACCESS SERVICE

5. Ordering Options for Switched and Special Access Service (Cont'd)

5.2 Access Order (Cont'd)

One service charge applies per customer order for all work or service to be provided at one time on the same premises, for the same customer. This charge includes the work associated with the first line in an access service request.

Additional line charges apply per line, trunk, channel or port connections or changes in type for lines after the first. Additional line charges do not apply for service reconfiguration as specified in Section 5.3, following.

The rates for the Service Charge and the Additional Line Charge are set forth in Section 16, following.

All other Access Service requests necessary to meet growth requirements will be assessed standard tariff nonrecurring charges. The orders for connection of reconfigured trunking must occur concurrently with the disconnect order. The due date for disconnect orders may be no longer than 90 days from the due date of the rearrangement connect date. This provision to waive access order charges will become effective with orders placed on June 17, 1997 and will expire on January 1, 1999. Orders for rearrangements placed on or prior to January 1, 1999 will qualify for the waiver of nonrecurring charges provided the due date for such rearrangement is no more than 90 days from January 1, 1999. This waiver of charges includes circuit grooming, and circuit roll-ups from a higher speed to a lower speed or from a lower speed to a higher speed including Voice Grade.

ACCESS SERVICE

5. Ordering Options for Switched and Special Access Service (Cont'd)

5.2 Access Order (Cont'd)

5.2.1 Access Order Service Date Intervals

To the extent the Access Service can be made available with reasonable effort, the Telephone Company will provide the Access Service in accordance with the Customer's requested interval, subject to the following conditions:

(A) The Telephone Company shall publish and make available to all customers, in the Telephone Company Business Office during normal business hours, a schedule of standard intervals applicable for Switched and Special Access Services. This schedule shall specify which services and the quantities of services that can be provided within the intervals. The Telephone Company shall provide such schedules and associated relevant information to all customers upon request and within a reasonable time period for standard or negotiated service intervals.

Access Services provided within these intervals will be installed during Telephone Company business days. If a Customer requests that installation be done outside of scheduled work hours, and the Telephone Company agrees to this request, the Customer will be subject to applicable Additional Labor Charges as described in Section 13 following.

(B) The Telephone Company will negotiate a service date interval with the customer when the service requested is not included in the published list of intervals. The Telephone Company will offer a service date based on the type and quantity of Access Services the customer has requested.

(C) The requested service may not exceed by more than six months the applicable service date, or, when there is no applicable service date, the service date established by the Telephone Company.

All part-time Television and Program Audio services are subject to a service inquiry. A service inquiry is a request to the Telephone Company to determine if facilities exist to provide the service ordered and to determine the service date on which service can be provided to the customer.

For services provided outside of the published intervals, the nonrecurring charge will equal the service connection charge and any appropriate charges for additional labor as described in Section 13 following.

ACCESS SERVICE

5. Ordering Options for Switched and Special Access Service (Cont'd)

5.2 Access Order (Cont'd)

5.2.2 Access Order Modifications

The customer may request a modification of its Access Order prior to the service date. The Telephone Company will make every effort to accommodate a requested modification when it is able to do so with the normal work force assigned to complete such an order within normal business hours. If the modification cannot be made with the normal work force during normal business hours the Telephone Company will schedule a new service date. All charges for Access Order modifications will apply on a per occurrence basis.

Any increase in the number of Special Access Service channels, will be treated as a new Access Order (for the increased amount only).

If order modifications are necessary to satisfy the transmission performance for a Special Access Service ordered by an Customer, these changes will be made without order modification charges being incurred by the Customer.

(A) Service Date Change Charge

Access Order service dates may be changed, but the new service date may not exceed the original service date by more than 30 calendar days. If the Customer-requested service date is more than 30 calendar days after the original service date, the order will be canceled by the Telephone Company and reissued with the appropriate cancellation charges applied. If the Telephone Company determines it can accommodate the customer's request without delaying service dates for orders of other customers, a new service date may be established that is prior to the original service date.

If the service date is changed to an earlier date, and the Telephone Company determines additional labor or extraordinary costs are necessary to meet the earlier service date requested by the customer, the customer will be notified by the Telephone Company that Expedited Order Charges as described in (D) following apply. Such charges will apply in addition to the Service Date Change Charge.

A Service Date Change Charge will apply, on a per order per occurrence basis, for each service date changed. The Service Date Change Charge is set forth in Section 16, following.

ACCESS SERVICE

5. Ordering Options for Switched and Special Access Service (Cont'd)

5.2 Access Order (Cont'd)

5.2.2 Access Order Modifications (Cont'd)

(B) Partial Cancellation Charge

Any decrease in the number of ordered Special Access Service channels will be treated as a partial cancellation and the charges as described in 5.2.3 following will apply.

(C) Design Change Charge

The Customer may request a design change to the service ordered. A design change is any change to an Access order which requires engineering review. An engineering review is a review by Telephone Company personnel, of the service ordered and the requested changes to determine what changes in the design, if any, are necessary to meet the changes requested by the customer. Design changes include such things as the addition or deletion of optional features or functions or a change in the type of Termination (Switched Access only), type of channel interface, type of Interface Group or technical specification package. Design Changes do not include a change of customer premises, End User premises, end office switch, Feature Group type or Special Access Service channel type. Changes of this nature will require the issuance of a new order and the cancellation of the original order with appropriate charges applied.

The Telephone Company will review the requested change, notify the Customer whether the change can be accommodated and specify if a new service date is required. If the Customer authorizes the Telephone Company to proceed with the design change, Design Change Charges will apply in addition to charges for Additional Engineering described in 13.1 following. Design Change Charges will apply on a per order, per occurrence basis. If a change of service date is required, the Service Date Change Charge as set forth in (A) preceding will also apply.

ACCESS SERVICE

5. Ordering Options for Switched and Special Access Service (Cont'd)

5.2 Access Order (Cont'd)

5.2.2 Access Order Modifications (Cont'd)

(D) Expedited Order Charge

(1) When placing an Access Order, a Customer may request a service date that is prior to the Telephone Company's published service date interval. A customer may also request an earlier service date on a pending Access Order. If the Telephone Company determines that service can be provided on the requested date, an Expedited Order Charge will apply.

A customer may request a change of end user premises within the same serving wire center. When this occurs, the service date is changed to reflect the standard service date interval. If the customer requests an earlier service date, an Expedited Order Charge will apply.

When an expedited service date is missed, the Expedited Order Charge will apply unless the missed service date is caused by the Telephone Company.

The Expedited Order Charge will apply to all services found in the tariff unless otherwise specified. This charge will be applied when the customer requests a service date that is prior to the standard service date interval on an Access Order, or when a customer requests an earlier service date on a pending Access Order.

The Expedited Order Charge, as set forth in Section 16, will apply on a per order basis for each day the service date is advanced.

Access Ordering Guidelines prohibit expedite orders when disconnecting services. (N)

ACCESS SERVICE

5. Ordering Options for Switched and Special Access Service (Cont'd)

5.2 Access Order (Cont'd)

5.2.2 Access Order Modifications (Cont'd)

(D) Expedited Order Charge (Cont'd)

(2) If the Telephone Company determines that provision of service on the expedited date will require additional work efforts outside of normal scheduled business hours, the customer will be notified and will be provided with an estimate of the additional charges involved. The charges will be based on the Additional Labor Rates described in Section 13 following and are in addition to the Expedited Order Charge described in (1) preceding. Actual charges assessed will not exceed the estimate by more than ten percent (10%).

When the request for expediting occurs subsequent to the issuance of the Access Order, a Service Date Change Charge as described in (A) proceeding also applies.

5.2.3 Cancellation of an Access Order

(A) A Customer may cancel an Access Order for the installation of service on any date prior to the service date. The cancellation date is the date the Telephone Company receives written or verbal notice from the Customer that the order is to be canceled. The verbal notice must be followed by written confirmation within 10 days. If a Customer is unable to accept Access Service within 30 calendar days of the original service date, the Customer has the choice of the following options:

- The Access Order shall be canceled and charges described in (B) following will apply, or
- Billing for the service will commence.

In such instances, the cancellation date or the billing date, depending on which option is selected by the customer, shall be the 31st day beyond the original service date of the Access Order.

ACCESS SERVICE

5. Ordering Options for Switched and Special Access Service (Cont'd)

5.2 Access Order (Cont'd)

5.2.3 Cancellation of an Access Order (Cont'd)

(B) When a Customer cancels an Access Order for the installation of service, a Cancellation Charge will apply as follows:

(1) Installation of Special Access Service facilities is considered to have started when the Telephone Company incurs any cost in connection therewith or in preparation thereof which would not otherwise have been incurred.

(X)
(X)
(X)

(2) Where the Customer cancels an Access Order prior to the start of installation of access facilities, no charges shall apply.

(3) Where installation of access facilities has been started prior to the cancellation, the charges specified in (a) or (b) following, whichever is lower, shall apply.

(a) A charge equal to the costs incurred in such installation, less estimated net salvage. Such charge is determined as detailed in (4) following.

(b) The charge for the minimum period of Special Access Service ordered by the Customer.

(4) Charges applicable as specified in (3)(a) preceding include the nonrecoverable cost of equipment and material ordered, provided or used, plus the nonrecoverable cost of installation and removal including the costs of engineering, labor, supervision, transportation, rights-of-way and other associated costs.

(C) When a Customer cancels an order for the discontinuance of service, no charges apply for the cancellation.

(D) If the Telephone Company misses a service date by more than 30 days due to circumstances over which it has direct control (excluding, e.g., acts of God, governmental requirements, work stoppages and civil commotions), the Customer may cancel the Access Order without incurring cancellation charges.

ACCESS SERVICE

5. Ordering Options for Switched and Special Access Service (Cont'd)

5.2 Access Order (Cont'd)

5.2.4 Selection of Facilities For Access Orders

(A) When there are analog or digital high capacity facilities to a Hub on order or in service for the Customer's use the Customer may request a specific channel or transmission path be used to provide the Special Access Service requested in an Access Order. The Telephone Company will make a reasonable effort to accommodate the Customer request.

(B) For all other Access Orders, the option to request a specific transmission path or channel is not provided except as provided for under Special Facilities Routing as set forth in Section 11. following.

5.2.5 Minimum Period

(A) Except as set forth in (B) following, the minimum period for which Access Service is provided and for which charges are applicable is one month.

(B) The minimum period for part-time Television and Program Audio Special Access Services is one day even though the service will be provided only for the duration of the event specified on the order (e.g., one-half hour, two hours, five hours, etc.). The minimum period for Voice Grade, High Capacity DS1 and DS3 Special Access Service is as set forth in 7.4.3 following.

ACCESS SERVICE

5. Ordering Options for Switched and Special Access Service (Cont'd)

5.2 Access Order (Cont'd)

5.2.6 Minimum Period Charges

When Access Service is disconnected prior to the expiration of the minimum period, charges are applicable for the balance of the minimum period. A customer's request for discontinuance of service shall be effective on the date requested in writing by the customer, provided that such written request is received by the Telephone Company at least thirty (30) business day prior to the date requested by the customer. A (C) customer shall not be liable for charges subsequent to the effective date of the discontinuance, provided that the minimum service period has expired.

The Minimum Period Charge for monthly billed services will be determined as follows:

(A) RESERVED FOR FUTURE USE

(B) For Special Access Service, the charge for a month or fraction thereof is the applicable monthly rate for the service as set forth in Section 16 following.

The Minimum Period Charge for part-time Television and Program Audio Services is the applicable daily rate for the service as set forth in Section 16 following.

5.2.7 Shared Use Facilities

Shared use (i.e., Switched and Special Access Service provided over the same analog or digital high capacity facilities) is allowed. Shared use facilities to a Hub will be ordered and provided as Special Access Service. Individual services utilizing these facilities must be ordered either as Switched Access Service or Special Access Service depending on the intended use. When placing the order for the individual service(s), the Customer must specify a channel assignment for each service ordered.

ACCESS SERVICE

5. Ordering Options for Switched and Special Access Service (Cont'd)

5.3 Common Channel Signaling Network Reconfiguration

Common Channel Signaling Network Reconfiguration charges apply on conversion of Feature Group D trunks from Multi-frequency (MF) to Common Channel Signaling (CCS). In addition to charges described in this Section, each order is subject to a Service Order Charge as described in Section 5.2, preceding.

(A) A Minimum Reconfiguration Charge applies for each reconfiguration order received.

(B) A Trunk Reconfiguration Charges apply per Feature Group D trunk in excess of 48 trunks reconfigured from MF to CCS in any single service order.

(C) The rates for CCS Network Reconfiguration are set forth in Section 16, following.

ACCESS SERVICE

6. RESERVED FOR FUTURE USE

ACCESS SERVICE

7. Special Access Service

7.1 General

Special Access Service provides a transmission path to connect customer designated premises*, either directly or through a Telephone Company Hub where bridging or multiplexing functions are performed. Special Access Service also provides a transmission path to connect a customer designated premises and a WATS Serving Office. Special Access Service includes all exchange access not utilizing Telephone Company end office switches.

The connections provided by Special Access Service can be either analog or digital. Analog connections are differentiated by spectrum and bandwidth. Digital connections are differentiated by bit rate.

7.1.1 Channel Types

There are seven types of channels used to provide Special Access Services. Each type has its own characteristics. All are subdivided by one or more of the following:

- Transmission specifications,
- Bandwidth,
- Speed (i.e., bit rate),
- Spectrum

Customers can order a basic channel and select from a list of available transmission parameters and channel interfaces, those that they desire to meet specific communications requirements.

For purposes of ordering channels, each has been identified as a type of Special Access Service. However, such identification is not intended to limit a customer's use of the channel nor to imply that the channel is limited to a particular use. For example, if a customer's equipment is capable of transmitting data over a channel that is identified as a Metallic Service in this Guide, there is no restriction against doing so.

* Telephone Company Centrex CO and CO-like switches and packet switches included in the Public Packet Switching Network (PPSN) are considered to be customer designated premises for purposes of this Guide.

ACCESS SERVICE

7. Special Access Service (Cont'd)

7.1 General (Cont'd)

7.1.1 Channel Types (Cont'd)

Following is a brief description of each type of channel:

Metallic - a channel for the transmission of low speed varying signals at rates up to 30 baud.

Telegraph Grade - a channel for the transmission of binary signals at rates of 0 to 75 baud or 0 to 150 baud.

Voice Grade - a channel for the transmission of analog signals within an approximate bandwidth of 300-3000 Hz.

Program Audio - a channel for the transmission of audio signals. The nominal frequency bandwidths are from 50 to 15,000 Hz, from 300 to 3500 Hz, from 100 to 50,000 Hz or from 50 to 8000 Hz.

Video - a channel for the transmission of standard 525 line/60 field monochrome or National Television Systems Committee color video signal and one or two associated 5 or 15 kHz audio signals. The provision and the bandwidth of the associated audio signals is a function of the channel interface selected by the customer.

Digital Data - A channel for the digital transmission of synchronous serial data at rates of 2.4, 4.8, 9.6, 19.2, 56 or 64 Kbps.

High Capacity - a channel for the transmission of isochronous serial digital data at rates of 1.544, 3.152, 6.312, 44.736 or 274.176 Mbps.

ACCESS SERVICE

7. Special Access Service (Cont'd)

7.1 General (Cont'd)

7.1.1 Channel Types (Cont'd)

The customer also has the option of ordering Voice Grade and analog and digital high capacity facilities (i.e., Group, Supergroup, Mastergroup, 1.544 Mbps, 3.152 Mbps, 6.312 Mbps, 44.736 Mbps and 274.176 Mbps) to a Telephone Company Hub for multiplexing to individual channels of a lower capacity or bandwidth. Descriptions of the types of multiplexing available at the Hubs, as well as the number of individual channels which may be derived from each type of facility are set forth in 7.2 following. Additionally, the customer may specify optional features for the individual channels derived from the facility to further tailor the channel to meet specific communications requirements. Descriptions of the optional features and functions available are also set forth in 7.2 following.

For example, a customer may order a 3.152 Mbps facility from a customer designated premises to a Telephone Company Hub for multiplexing to two 1.544 Mbps channels. The 1.544 Mbps channels may be further multiplexed at the same or a different Hub to Voice Grade or Wideband Analog (i.e., Group Level) channels or may be extended to other customer designated premises. Optional features may be added to either the 1.544 Mbps or the Voice Grade Channels.

7.1.2 Rate Categories

There are three basic rate categories which apply to Special Access Service:

- Channel Terminations (described in 7.1.2(A) following)
- Channel Mileage (described in 7.1.2(B) following)
- Optional Features and Functions (described in 7.1.2(C) following)

(A) Channel Termination

The Channel Termination rate category provides for the communications path between a customer designated point or points of termination (POT) and/or between customer designated point(s) of termination and/or the serving wire center.

Included as part of the Channel Termination is a standard channel interface arrangement which defines the technical characteristics associated with the type of facilities to which the access service is to be connected at the Point of Termination (POT) and the type of signaling capability, if any. The signaling capability itself is provided as an optional feature as set forth in (E) following. One Channel Termination charge applies per customer designated POT at which the channel is terminated. This charge will apply even if the customer designated POT(s) and/or serving wire center are located in the same building.

ACCESS SERVICE

7. Special Access Service (Cont'd)

7.1 General (Cont'd)

7.1.2 Rate Categories (Cont'd)

(A) Channel Termination (Cont'd)

Rates for End User Channel Terminations are subject to the rules governing Competitive and Non-Competitive Counties as discussed in Section 16.10. Where Competitive and Non-Competitive Rates are present the Channel Termination consists of two different rate elements: an End User Channel termination that serves the customer premises and an Interexchange Carrier (IC) Point of Presence (POP) that is collocated in a Company serving wire center. The customer will be charged for both the End User Channel Termination and the IC Channel Termination.

(N)

(B) Channel Mileage

The Channel Mileage Rate Category provides for the transmission facilities between the serving wire centers associated with two customer designated premises, between a serving wire center associated with a customer designated premises and a Telephone Company Hub or between two Telephone Company Hubs. Channel Mileage rates are made up of the Channel Mileage Facility rate and the Channel Mileage Termination Rate

(N)

(1) Channel Mileage Facility

The Channel Mileage Facility Rate recovers the cost for the transmission path which extends between the Telephone Company serving wire centers and/or Hub(s) and includes primarily outside plant used to provide the facility.

(2) Channel Mileage Termination

The Channel Mileage Termination Rate Recovers the cost for end office equipment associated with terminating the facility (i.e., basic circuit equipment and terminations at serving wire centers and Hubs), including circuit equipment. The Channel Mileage Termination Rate will apply at the serving wire center(s) for each customer designated premises and Telephone Company Hub where the channel is terminated. If the Channel Mileage is between Telephone Company bridging Hubs, the Channel Mileage Termination Rate will apply per Telephone Company designated Hub. When the Channel Mileage is zero (i.e., co-located serving wire centers), neither the channel mileage facility nor the Channel Mileage Termination Rate will apply.

ACCESS SERVICE

7. Special Access Service (Cont'd)

7.1 General (Cont'd)

7.1.2 Rate Categories (Cont'd)

(C) Optional Features and Functions

The Optional Features and Functions rate categories provide for optional features and functions which may be added to a Special Access Service to improve its quality or utility to meet specific communications requirements. These are not necessarily identifiable with specific equipment, but rather represent the end result in terms of performance characteristics which may be obtained. These characteristics may be obtained by using various combinations of facilities. Although the equipment necessary to perform the specified function may be installed at various locations along the path of the service, they will be charged for as a single rate element.

Examples of Optional Features and Functions that are available include, but are not limited to, the following:

- Signaling Capability
- Hubbing Functions (i.e., Bridging or Multiplexing)
- Conditioning
- Transfer Arrangements

A Hub is a Telephone Company designated serving wire center at which bridging or multiplexing functions are performed, as set forth in 7.4.6 following. The bridging functions performed may be (1) to connect three or more customer designated premises in a multipoint arrangement. The multiplexing functions are to channelize analog or digital facilities to individual services requiring a lower capacity or bandwidth.

Descriptions for each of the available Optional Features and Functions are set forth in 7.2 following.

ACCESS SERVICE

7. Special Access Service (Cont'd)

7.1 General (Cont'd)

7.1.3 Service Configurations

There are two types of service configurations over which Special Access Services are provided: two-point service and, multipoint service.

(A) Two-Point Service

A two-point service connects two customer designated premises either on a directly connected basis or through a Hub where multiplexing functions are performed.

Applicable rate elements are:

- Channel Termination
- Channel Mileage (as applicable)
- Optional Features and Functions (when applicable)

In addition, a Special Access Surcharge, as described in 7.4.2 following , may be applicable.

The following diagram depicts two-point Voice Grade service connecting two customer designated premises located 15 miles apart. The service is provided with C-Type conditioning.

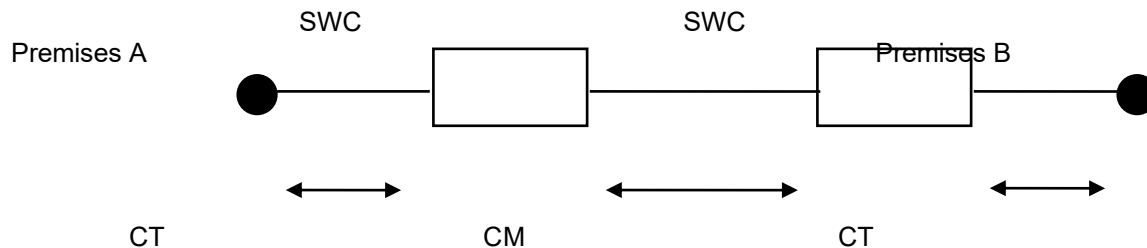

Applicable rate elements are:

- CT - Channel Terminations (two applicable)
- CM - Channel Mileage (may consist of channel mileage facility and channel mileage termination)
- Optional Features as ordered by customer

ACCESS SERVICE

7. Special Access Service (Cont'd)

7.1 General (Cont'd)

7.1.3 Service Configurations (Cont'd)

(B) Multipoint Service

Multipoint service connects three or more customer designated premises through a Telephone Company Hub. Only certain types of Special Access Service are provided as multipoint service. These are so designated in the Service Descriptions set forth in 7.2 following.

Multipoint service utilizing a customized technical specifications package, as set forth in 7.2 following, will be provided when technically possible. If the Telephone Company determines that the requested characteristics for multipoint service are not compatible, the customer will be advised and given the opportunity to change the order.

When ordering, the customer will specify the bridging Hub(s). Specific bridging hub location information is incorporated in Exchange Carrier Association Tariff F.C.C. No. 4.

Applicable Rate Elements are:

- Channel Termination (one per customer designated premises).
- Channel Mileage (as applicable between each customer designated premises and the Hub and between Hubs).
- Bridging.
- Additional Optional Features and Functions (when applicable).

In addition, the Special Access Surcharge, as described in 7.4.2 following, may apply.

ACCESS SERVICE

7. Special Access Service (Cont'd)

7.1 General (Cont'd)

7.1.3 Service Configurations (Cont'd)

(B) Multipoint Service (Cont'd)

Example: Voice Grade Multipoint service connecting four customer premises via two customer specified bridging Hubs.

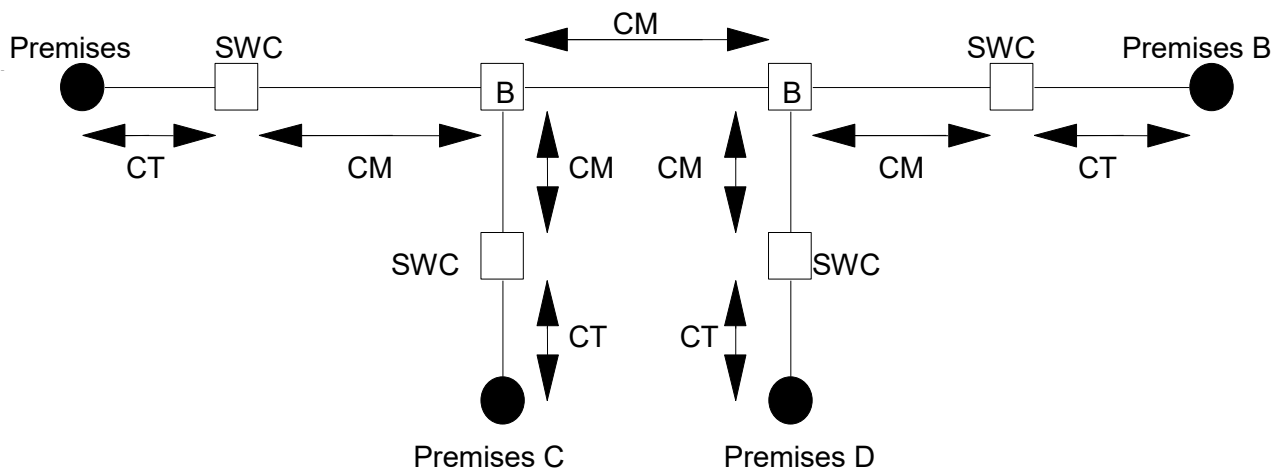

Applicable rate elements

- CT - Channel Terminations (four)
- CM - Channel Mileage (5 sections;
consist of channel mileage
and channel mileage)
- B - Bridging Optional Feature (6 bridge
Other Optional Features as ordered by

ACCESS SERVICE

7. Special Access Service (Cont'd)

7.1 General (Cont'd)

7.1.4 Alternate Use

Alternate Use occurs when a service is arranged by the Telephone Company so that the customer can select different types of transmission at different times. The customer may use a service in any privately beneficial manner. However, where technical engineering changes are required to effectuate an alternate use, the Telephone Company will make such special arrangements available on an individual case basis.

The arrangement required to transfer the service from one operation to the other (i.e., the transfer relay and control leads) will be rated and provided on an individual case basis and filed in Section 12., Specialized Service or Arrangements. The customer will pay the stated tariff rates for the Access Service rate elements for the service ordered (i.e., Channel Terminations and Channel Mileage [as applicable] and Optional Features [if any]).

7.1.5 Special Facilities Routing

A customer may request that the facilities used to provide Special Access Service be specially routed. The regulations, rates and charges for Special Facilities Routing (i.e., Avoidance, Diversity and Cable-Only) are set forth in Section 11. following.

7.1.6 Design Layout Report

At the request of the customer, the Telephone Company will provide to the customer the make-up of the facilities and services provided under this Guide as Special Access Service to aid the customer in designing its overall service. This information will be provided in the form of a Design Layout Report. The Design Layout Report will be provided to the customer at no charge, and will be reissued or updated whenever these facilities are materially changed.

ACCESS SERVICE

7. Special Access Service (Cont'd)

7.1 General (Cont'd)

7.1.7 Acceptance Testing

At no additional charge, the Telephone Company will, at the customer's request, cooperatively test, at the time of installation, the following parameters:

(A) For analog services, acceptance tests will include tests for loss, 3-tone slope, DC continuity, operational signaling, C-notched noise, frequency response, harmonic distortion, phase jitter, impulse noise, C-message noise, and delay distortion when these parameters are specified in the order for service. Additionally, for Voice Grade Services, a balance (improved loss) test will be made if the customer has ordered the improved loss optional feature.

(B) For other services, acceptance tests will include tests for the parameters specified in the order for service.

In addition to the above tests, Additional Cooperative Acceptance Testing for Voice Grade Service to test other parameters, as described in Section 13.3.6 following, is available at the customer's request. All test results will be made available to the customer upon request.

7.1.8 Ordering Options and Conditions

Special Access Service is ordered under the Access Order provision set forth in 5. preceding. Also included in that section are other charges which may be associated with ordering Special Access Service (e.g., Service Date Change Charge, Cancellation Charge, etc.).

ACCESS SERVICE

7. Special Access Service (Cont'd)

7.2 Service Descriptions

For the purposes of ordering, there are seven categories of Special Access Service. These are:

Metallic	MT
Telegraph Grade	TG
Voice Grade	VG
Program Audio	AP
Video	TV
Digital Data	DA
High Capacity	HC

Each service consists of a basic channel to which a technical specifications package (customized or predefined), channel interface(s) and when desired optional features and functions are added to construct the service desired by the customer. Each of the components of the service are described in this section.

Customized technical specifications packages will be provided where technically feasible. If the Telephone Company determines that the requested parameter specifications are not compatible, the customer will be advised and given the opportunity to change the order.

When a customized channel is ordered the customer will be notified whether Additional Engineering Charges apply. In such cases, the customer will be given an estimate of the hours to be billed before any further action is taken on the order.

The channel description specifies the characteristics of the basic channel and indicates whether the channel is provided between customer designated premises or is provided between a customer designated premises and a Telephone Company Hub where bridging or multiplexing functions are performed or between a customer designated premises and a WATS Serving Office.

The technical specifications packages information indicates the transmission parameters that are available with each technical specifications package. This information is displayed in a matrix with the transmission parameters listed down the left side and the packages listed across the top. Each package is identified by a code, e.g., VGC. The first two letters of the code indicate the category of Special Access Service to which the parameters are applicable. These two letter codes are shown in parentheses following the category of Special Access Service above.

ACCESS SERVICE

7. Special Access Service (Cont'd)

7.2 Service Descriptions (Cont'd)

The letter "C" following the two letter code indicates the technical specifications package for a customized service. A numeric or alpha-numeric designation following the two letter code indicates the specific predefined package. For a customized service, the customer may select any parameters available with that category of service as long as the parameters are compatible. When appropriate, the Technical Reference which contains detailed specifications for the parameters is shown following the matrix.

Channel interface at each Point of Termination on a two-point service may be symmetrical or asymmetrical. On a multipoint service they must also be symmetrical or asymmetrical, but communications can only be provided between compatible channel interfaces. Only certain channel interfaces are compatible. These are set forth in 7.3.5 following, in a combination format.

Only certain channel interface combinations are available with the predefined technical specifications packages. These are delineated in the Technical References set forth at the end of this 7.2. When a customized channel is requested, all channel interface combinations available with the specified type of service are available with the customized channel.

The optional features and functions available with each type of Special Access Service are described in this section. The optional features and functions information also indicates with which technical specifications packages they are available. Such information is displayed in a matrix with the optional feature or function listed down the left side and the technical specifications package listed across the top.

The Telephone Company will maintain existing transmission specifications on services installed prior to the effective date of this Guide except that existing services with performance specifications excluding the standard listed in this provision will be maintained at the performance levels specified in this Guide.

ACCESS SERVICE

7. Special Access Service (Cont'd)

7.2 Service Descriptions (Cont'd)

All services installed after the effective date of this Guide will conform to the transmission performance standards contained in this Guide or in the following Technical References for each category of service:

Metallic	PUB 62502
Telegraph Grade	PUB 62502
Voice Grade	PUB 62501 and associated Addendum PUB 41004, Table 4
Program Audio	PUB 62503 and associated Addendum
Video	PUB 62504 and associated Addendum
Digital Data	PUB 62507 PUB 62310 TA-TSY-000192 TA-TSY-000280
High Capacity	PUB 62508 PUB 62411 TR-NPL-000054

7.2.1 Metallic Service

(A) Basic Channel Description

A Metallic channel is an unconditioned two-wire channel capable of transmitting low speed varying signals at rates up to 30 baud. This channel is provided by metallic or equivalent facilities. Metallic channels are provided between customer designated premises or between a customer designated premises and a Telephone Company Hub where bridging functions are performed. Interoffice metallic facilities will be limited in length to a total of five miles per circuit.

(B) Technical Specifications Packages

<u>Parameter</u>	<u>C*</u>	<u>Package MT-</u>		
		<u>1</u>	<u>2</u>	<u>3</u>
DC Resistance				
Between Conductors	X	X	X	
Loop Resistance	X			X
Shunt Capacitance	X			X

The technical specifications are delineated in Technical Reference PUB 62502.

ACCESS SERVICE

7. Special Access Service (Cont'd)

7.2 Service Descriptions (Cont'd)

7.2.1 Metallic Service (Cont'd)

(C) Channel Interfaces

The following channel interface combinations represent channel interfaces without signaling:

DC to DC

DS to DC

All other channel interfaces for Metallic Service are provided with signaling.

Compatible channel interfaces are set forth in 7.3.5(A) following.

(D) Optional Features and Functions

(1) Central Office Bridging Capability

(a) Three Premises Bridging-Provision of tip-to-tip and ring-to-ring connection in a central office of a metallic pair to a third customer designated premises.

(b) Series Bridging of up to 26 customer designated premises.**

The following table shows the technical specifications packages with which the optional features and functions are available.

	Available with Technical Specifications Package MT -			
	<u>C</u>	<u>1</u>	<u>2</u>	<u>3</u>
Three Premises Bridging	X	X		X
Series Bridging	X		X	

(2) Digiline

Provides digital interface capability as further described in Section 7.2.3(D)(10) following.

** No additional charge applies for series bridging.

ACCESS SERVICE

7. Special Access Service (Cont'd)

7.2 Service Descriptions (Cont'd)

7.2.2 Telegraph Grade Service

(A) Basic Channel Description

A Telegraph Grade channel is an unconditioned channel capable of transmitting binary signals at rates of 0-75 baud or 0-150 baud. This channel is furnished for half-duplex or duplex operation.

Telegraph Grade channels are provided between customer designated premises or between a customer designated premises and a Telephone Company Hub.

(B) Technical Specifications Packages

<u>Parameter</u>	<u>Package TG-</u>		
	<u>C*</u>	<u>1</u>	<u>2</u>
Telegraph Distortion	X	X	X

The technical specifications are delineated in Technical Reference PUB 62502.

(C) Channel Interfaces

Compatible channel interfaces are set forth in 7.3.5(B) following.

(D) Optional Features and Functions

(1) Telegraph Bridging (two-wire and four-wire)

The following table shows the technical specifications packages with which the optional features and functions are available.

	<u>Available with Technical Specifications Package TG-</u>		
	<u>C</u>	<u>1</u>	<u>2</u>
Telegraph Bridging	X	X	X

(2) Digiline

Provides digital interface capability as further described in Section 7.2.3(D)(10) following.

ACCESS SERVICE

7. Special Access Service (Cont'd)

7.2 Service Descriptions (Cont'd)

7.2.3 Voice Grade Service

(A) Basic Channel Description

A Voice Grade channel, including a special access line used in connection with switched access service, is a channel which provides voice frequency transmission capability in the nominal frequency range of 300 to 3000 Hz and may be terminated two-wire or four-wire. Voice Grade channels are provided between customer designated premises or between a customer designated premises and a Telephone Company Hub. A special access line used in connection with switched access service is provided between a customer designated premises and a Telephone Company end office. When the end office serving the customer is not a WATS serving office, the mileage between the customer's end office and WATS serving office will be charged channel mileage rates.

(B) Technical Specifications Packages

<u>Parameter</u>	<u>Package VG-</u>												
	<u>C*</u>	<u>1</u>	<u>2</u>	<u>3</u>	<u>4</u>	<u>5</u>	<u>6</u>	<u>7</u>	<u>8</u>	<u>9</u>	<u>10</u>	<u>11</u>	<u>12</u>
Attenuation													
Distortion	X	X	X	X	X	X	X	X	X	X	X	X	X
C-Message													
Noise	X	X	X	X	X	X	X	X	X	X	X	X	X
Echo Control	X	X	X	X		X		X	X			X	X
Envelope Delay													
Distortion	X						X	X	X	X	X	X	X
Frequency													
Shift	X						X	X	X	X	X	X	X
Improved													
Return Loss	X	X	X	X	X	X	X	X	X	X	X	X	X
Impulse Noise	X					X	X	X	X	X	X	X	X
Intermodulation													
Distortion	X						X	X	X	X	X	X	
Loss Deviation	X	X	X	X	X	X	X	X	X	X	X	X	X
Phase Hits, Gain Hits, and Dropouts	X												
Phase Jitter	X						X	X	X	X	X	X	
Signal-to-C Message Noise			X										
Signal-to-C Notch Noise	X					X	X	X	X	X	X	X	X

ACCESS SERVICE

7. Special Access Service (Cont'd)

7.2 Service Descriptions (Cont'd)

7.2.3 Voice Grade Service (Cont'd)

(B) Technical Specifications Packages (Cont'd)

The technical specifications for these parameters (except for dropouts, gain hits, and phase hits) are delineated in Technical Reference PUB 62501 and associated Addendum. The technical specifications for dropouts, phase hits, and gain hits are delineated in Technical Reference PUB 41004, Table 4.

(C) Channel Interfaces

The following channel interface combinations represent channel interfaces without signaling:

DA to DA	NO to DA
DB to DA	NO to NO
DB to NO	TF to TF

All other channel interfaces for Voice Grade are provided with signaling.

Compatible channel interfaces are set forth in 7.3.5(C) following.

(D) Optional Features and Functions

(1) Central Office Bridging Capability

(a) Voice Bridging (two-wire and four-wire)

(b) Data Bridging (two-wire and four-wire)

(c) Telemetry and Alarm Bridging (Passive Bridging)

(2) Conditioning

Conditioning provides more specific transmission characteristics for voice grade services. C-Type conditioning controls attenuation distortion and envelope delay distortion. Sealing Current helps maintain continuity on dry metallic loops.

For two-point service, the parameters apply to each service. For multipoint services, the parameters apply to each mid-link or end-link. C-Type conditioning and Data Capability may be combined on the same service.

ACCESS SERVICE

- 7. Special Access Service (Cont'd)
- 7.2 Service Descriptions (Cont'd)
- 7.2.3 Voice Grade Service (Cont'd)
- (D) Optional Features and Functions (Cont'd)
- (2) Conditioning (Cont'd)
- (a) C-Type Conditioning

C-Type Conditioning is provided for the additional control of attenuation distortion and envelope delay distortion on data services. The attenuation distortion and envelope delay distortion specifications for C-Type Conditioning are:

Attenuation Distortion
(Frequency Response)
Relative to 1004 Hz

<u>Frequency Range (Hz)</u>	<u>Variation (dB)</u>
400-2800	-1.0 to +2.0
300-3000	-1.0 to +3.0
3000-3200	-2.0 to +6.0

Envelope Delay Distortion

<u>Frequency Range (Hz)</u>	<u>Variation (micro-seconds)</u>
1000-2600	100
800-2600	200
600-2600	300
500-2800	600
500-3000	3000

- (b) Sealing Current Condition

Sealing Current Conditioning is provided to help maintain continuity on dry metallic loops. It is usually associated with four-wire DA or NO type channel interfaces.

ACCESS SERVICE

7. Special Access Service (Cont'd)

7.2 Service Descriptions (Cont'd)

7.2.3 Voice Grade Service (Cont'd)

(D) Optional Features and Functions (Cont'd)

(3) Customer Specified Premises Receive Level

This option allows the customer to specify the receive level at the Point of Termination. This level must be within a specific range on effective four-wire transmission. The ranges are delineated in Technical Reference PUB 62501.

(4) Hybrid

Provides conversion from a four-wire channel to two-wire termination at a customer designated premises. Required to meet effective four-wire performance with a two-wire customer designated premise channel interface.

(5) Improved Return Loss

(a) On Effective Four-Wire Transmission at Four-Wire Point of Termination (applicable to each two-wire port): Provides for a fixed 600 ohm impedance, variable level range and simplex reversal. Telephone Company equipment is required at the customer's premises where this option is ordered. The Improved Return Loss parameters are delineated in Technical Reference PUB 62501.

(b) On Effective Two-Wire Transmission at Two-Wire Point of Termination: Provides for more stringent Echo Control specifications. In order for this option to be applicable, the transmission path must be four-wire at one POT and two-wire at the other POT. Placement of Telephone Company equipment may be required at the customer's premises with the two-wire POT. The Improved Return Loss parameters are delineated in Technical reference PUB 62501.

ACCESS SERVICE

7. Special Access Service (Cont'd)

7.2 Service Descriptions (Cont'd)

7.2.3 Voice Grade Service (Cont'd)

(D) Optional Features and Functions (Cont'd)

(6) Data Capability

Data Capability provides transmission characteristics suitable for data communications. Specifically, Data Capability provides for the control of Signal to C-Notched Noise Ratio and intermodulation distortion. It is available for two-point services or multipoint services.

The Signal to C-Notched Noise Ratio and intermodulation distortion parameter or Data Capability are:

- Signal to C-Notched Noise Ratio is equal to or greater than 32db
- Intermodulation distortion:
 - Signal to second order modulation products (R2) is equal to or greater than 38db.
 - Signal to third order modulation products (R3) is equal to or greater than 42db.

When a service equipped with Data Capability is used for voice communications, the quality of the voice transmission may not be satisfactory.

ACCESS SERVICE

- 7. Special Access Service (Cont'd)
- 7.2 Service Descriptions (Cont'd)
- 7.2.3 Voice Grade Service (Cont'd)
- (D) Optional Features and Functions (Cont'd)
- (7) Telephoto Capability

Telephoto Capability provides transmission characteristics suitable for telephotographic communications. Specifically, Telephoto Capability is provided for the control of attenuation distortion and envelope delay distortion on telephotographic services. The attenuation distortion and envelope delay distortion parameters for Telephoto Capability are:

Attenuation Distortion
(1004Hz Reference)

<u>Frequency Range (Hz)</u>	<u>Variation (dB)</u>
500-3000	-0.5 to +1.5
300-3200	-1.0 to +2.5

Envelope Delay Distortion

<u>Frequency Range (Hz)</u>	<u>Variation (mcs)</u>
1000-2600	110
800-2800	180

- (8) Signaling Capability

Signaling Capability provides for the process by which one customer premises alerts another customer premises on the same service with which it wishes to communicate.

ACCESS SERVICE

7. Special Access Service (Cont'd)

7.2 Service Descriptions (Cont'd)

7.2.3 Voice Grade Service (Cont'd)

(D) Optional Features and Functions (Cont'd)

(9) The following table shows the technical specifications packages with which the optional features and functions are available.

	<u>C</u>	Available with Technical Specifications Package VG-											
		<u>1</u>	<u>2</u>	<u>3</u>	<u>4</u>	<u>5</u>	<u>6</u>	<u>7</u>	<u>8</u>	<u>9</u>	<u>10</u>	<u>11</u>	<u>12</u>
C-Type													
Conditioning	X					X	X	X	X	X	X		
Central Office													
Bridging													
Capability	X		X			X	X				X	X	X
Customer													
Specified													
Premises													
Receive													
Level	X		X	X				X	X	X			
DA-Type													
Conditioning	X					X	X				X		
Improved Return													
Loss:													
For Effective													
Four-Wire													
Transmission	X	X	X	X	X	X	X	X	X	X	X	X	X
For Effective													
Two-Wire													
Transmission	X		X	X				X					
Sealing Current													
Conditioning	X						X						
Telephoto													
Capability	X											X	

ACCESS SERVICE

- 7. Special Access Service (Cont'd)
- 7.2 Service Descriptions (Cont'd)
- 7.2.3 Voice Grade Service (Cont'd)
- (D) Optional Features and Functions (Cont'd)
- (10) Digiline Option Description* (C)

The DIGILINE option allows individual channel services to be terminated on a two-wire or four-wire digital basis to a customer. This option is provided to allow a digital interface between a customer serving central office and a Telephone Company designated Hub wire center terminating in a Digital Access Cross-connect System (DACCS). The DIGILINE option rates consist of nonrecurring and monthly charges for the digital interface as well as an interoffice transport rate between the customer's serving office and a Telephone Company designated Hub wire center location. DIGILINE rates apply in addition to any monthly recurring and non-recurring charges for the basic analog service ordered.

	(C)
--	-----

*Effective June 30, 2023, orders for new Digiline services are no longer permitted. The Telephone Company will continue to provide Digiline pursuant to this Section 7.2.3 on any existing Digiline service that is in service as of June 30, 2023.

	(C)
--	-----

ACCESS SERVICE

7. Special Access Service (Cont'd)

7.2 Service Descriptions (Cont'd)

7.2.4 Program Audio Service

(A) Basic Channel Description

A Program Audio channel is a channel measured in Hz for the transmission of a complex signal voltage. The actual bandwidth is a function of the channel interface selected by the customer. Only one-way transmission is provided. Program Audio channels are provided between customer designated premises or between a customer designated premises and a Telephone Company Hub.

(B) Technical Specifications Packages

Parameter	Package AP-				
	C*	1	2	3	4
Actual Measured Loss	X	X	X	X	X
Amplitude Tracking	X				
Crosstalk	X	X	X	X	
Distortion Tracking	X				
Gain/Frequency					
Distortion	X	X	X	X	X
Group Delay	X				
Noise	X	X	X	X	X
Phase Tracking	X				
Short-Term Gain					
Stability	X				
Short-Term Loss	X				
Total Distortion	X	X	X	X	X

The technical specifications are delineated in Technical Reference PUB 62503 and associated Addendum.

ACCESS SERVICE

7. Special Access Service (Cont'd)

7.2 Service Descriptions (Cont'd)

7.2.4 Program Audio Service (Cont'd)

(C) Channel Interfaces

The following channel interfaces (CIs) define the bandwidths that are available for a Program Audio channel:

<u>CI</u>	<u>Bandwidth</u>
PG-1	Nominal frequency from 50 to 15000 Hz
PG-3	Nominal frequency from 200 to 3500 Hz
PG-5	Nominal frequency from 100 to 5000 Hz
PG-8	Nominal frequency from 50 to 8000 Hz

Compatible channel interfaces are set forth in 7.3.5(D) following.

(D) Optional Features and Functions

(1) Central Office Bridging Capability

Distribution Amplifier

(2) Gain Conditioning

Control of 1004 Hz AML at initiation of service to 0dB \pm 0.5 dB.

(3) Stereo

Provision of a pair of gain/phase equalized channels for stereo applications. (Additional AP channel must be ordered separately.)

The following table shows the technical specifications packages with which the optional features and functions are available.

	<u>Available with Technical Specifications Package AP-</u>				
	<u>C</u>	<u>1</u>	<u>2</u>	<u>3</u>	<u>4</u>
Central Office Bridging Capability	X	X	X	X	X
Gain Conditioning	X	X	X	X	X
Stereo	X				X

ACCESS SERVICE

7. Special Access Service (Cont'd)

7.2 Service Descriptions (Cont'd)

7.2.5 Digital Data Service

(A) Basic Channel Description

A Digital Data channel is a channel for duplex four-wire transmission of synchronous serial data at the rate of 2.4, 4.8, 9.6, 19.2, 56 or 64 Kbps. The actual bit rate is a function of the channel interface selected by the customer. The channel provides a synchronous service with timing provided by the Telephone Company through the Telephone Company's facilities to the customer in the received bit stream. Digital Data channels are provided between customer designated premises or between a customer premises and a Telephone Company Hub. Sub rating is not available at the 19.2 kbps speed and the 64 kbps speed requires B82S line code formatted signal.

Secondary Channel Capability (SSC) is a derived companion digital transmission path that is independent of the primary data path and operates at a substantially lower bit rate. This derived channel allows the customer to perform network management functions during the normal operation of the network. This diagnostic channel utilizes a portion of a customer's previously unavailable data bit stream allowing for the ability to remotely control and test the network out of service. Special customer equipment is necessary to utilize the benefits of the SSC. Customers not wishing to utilize the capability will not be impacted. Due to the transmission equipment restrictions, SSC cannot be provided on 56.0 Kbps circuits that require the installation of loop repeater equipment for provision of service.

The customer may provide the Channel Service Unit-type equipment or other Network Channel Terminating Equipment associated with the Digital Data channel at the customer premises. The interim program for interconnection of such equipment is set forth in Technical Reference PUB AS No. 1.

ACCESS SERVICE

7. Special Access Service (Cont'd)

7.2 Service Descriptions (Cont'd)

7.2.5 Digital Data Service (Cont'd)

(B) Technical Specifications Packages

<u>Parameter</u>	<u>Package DA-</u>					
	<u>1</u>	<u>2</u>	<u>3</u>	<u>4</u>	<u>5</u>	<u>6</u>
Error-Free Seconds	X	X	X	X	X	X

The Telephone Company will provide a channel capable of meeting a monthly average performance equal to or greater than 99.875% error-free seconds.

Voltages which are compatible with Digital Data Service are delineated in Technical Reference PUB 62507.

(C) Channel Interfaces

The following channel interfaces (CIs) define the bit rates that are available for a Digital Data channel:

<u>CI</u>	<u>Bit Rate</u>
DU5-19	19.2 kbps
DU5-24	2.4 kbps
DU5-48	4.8 kbps
DU5-56	56.0 kbps
DU5-64	64.0 kbps
DU5-96	9.6 kbps

Compatible channel interfaces are set forth in 7.3.5(F) following.

ACCESS SERVICE

7. Special Access Service (Cont'd)

7.2 Service Descriptions (Cont'd)

7.2.5 Digital Data Service (Cont'd)

(D) Optional Features and Functions

The following table shows the technical specifications packages with which the optional features and functions are available.

	Available with Technical Specifications Package DA-			
	<u>1</u>	<u>2</u>	<u>3</u>	<u>4</u>
Central Office Bridging Capability	X	X	X	X

(1) DIGILINE

Provides digital interface capability as further described in Section 7.2.3(D)(10) preceding.

(2) Secondary Channel

Digital Data Service Secondary Channel is an option available to customers of Digital Data Service. This option is a separate digital channel that operates in concert with a companion Digital Data Service primary channel but at a substantially lower bit rate than the primary channel. The secondary Channel permits a customer to perform network management functions, including testing of the network and peripheral devices, without taking the network out of service or reducing the speed of the primary channel. Technical parameters and specifications associated with this option are set forth in Bellcore Technical Reference TR-NPL-000157 ISSUE 2, 1986.

(3) Digital Data Service Bridging

Digital Data Service Bridging is a service which allows a customer the ability to bridge either 2.4, 4.8, 9.6 or 56 kbs data circuit using a Multipoint Junction Module with six multi-junction units (MJUs), each consisting of four branch legs and a control leg. The control leg transmits and receives from all of the branch legs. The branch legs transmit to and receive from the control leg only, and not other branch legs. This service is only available between a customer premises and a Telephone Company designated digital hub.

ACCESS SERVICE

7. Special Access Service (Cont'd)

7.2 Service Descriptions (Cont'd)

7.2.6 High Capacity Service

(A) Basic Channel Description

A High Capacity channel is a channel for the transmission of 1.544 or 44.736 Mbps isochronous serial data. The actual bit rate is a function of the channel interface selected by the customer. High Capacity channels are provided between customer designated premises or between a customer designated premises and a Telephone Company Hub.

The customer may provide the Network Channel Terminating Equipment associated with the High Capacity channel at the customer's premises. The interim program for interconnection of such equipment is set forth in Technical Reference PUB AS No. 1.

(B) Technical Specifications Packages

<u>Parameters</u>	<u>Package HC-</u>				
	<u>1</u>	<u>1C</u>	<u>2</u>	<u>3</u>	<u>4</u>
Error-Free Seconds	X	X	X	X	X

A channel with technical specifications package HC1 will be capable of an error-free second performance of 98.75% over a continuous 24 hours period as measured at the 1.544 Mbps rate through a CSU equivalent which is designed, manufactured, and maintained to conform with the specifications contained in Technical Reference PUB 62411.

(C) Channel Interfaces

The following channel interfaces (CIs) define the bit rates that are available for a High Capacity channel:

<u>CI</u>	<u>Bit Rate</u>
DS-15*	1.544 Mbps (DS1)
DS-44	44.736 Mbps (DS3)

Compatible channel interfaces are set forth in 7.3.5(G) following.

* A 64.0 kbps channel is available as a channel(s) of a 1.544 Mbps facility to a Telephone Company Hub.

ACCESS SERVICE

7. Special Access Service (Cont'd)

7.2 Service Descriptions (Cont'd)

7.2.6 High Capacity Service (Cont'd)

(D) Optional Features and Functions

(1) Automatic Protection Switching

Switching equipment placed at both ends of a duplicate standby service to automatically switch the standby service to the active state in the event of service failure. Duplicate 1.544 Mbps Service must also be ordered. Equipment at the customer premises will be provided under tariff only if it existed in the Telephone Company inventory as of November 18, 1983. This feature is not available with channels utilizing the clear channel capability (B8ZS) line code.

(2) Transfer Arrangement

An arrangement that affords the customer an additional measure of flexibility in the use of their access channel(s). The arrangement can be utilized to transfer a leg of a Special Access Service to either a spare or working channel that terminates in either the same or a different customer premises. A key activated or dial up control service is required to operate the transfer arrangement. A spare line, if required, is not included as part of the option. This feature is not available with channels utilizing the clear channel capability (B8ZS) line code.

(3) Central Office Multiplexing

(a) DS3 to DS1

An arrangement that converts a 44.736 Mbps channel to 28 DS1 channels using digital time division multiplexing.

ACCESS SERVICE

7. Special Access Service (Cont'd)

7.2 Service Descriptions (Cont'd)

7.2.6 High Capacity Service (Cont'd)

(D) Optional Features and Functions (Cont'd)

(3) Central Office Multiplexing (Cont'd)

(b) DS1 to Voice

An arrangement that converts a 1.544 Mbps channel to 24 channels for use with Voice Grade Services. A channel at this DS1 to the Hub can also be used for a Digital Data Service.

(c) DS1 to DS0

An arrangement that converts a 1.544 Mbps channel to twenty-three 64.0 kbps channels utilizing digital time division multiplexing. Required with DS1 to Digital Data channels hub multiplexing capability (MQ1).

The following table shows the technical specifications packages with which the optional features and functions are available.

	Available with Technical Specifications Package HC-				
	<u>1</u>	<u>1C</u>	<u>2</u>	<u>3</u>	<u>4</u>
Automatic Protection Switching	X				
Central Office Multiplexing:					
DS3 to DS1				X	
DS1 to Voice	X				
DS1 to DS0	X				
Transfer Arrangement	X				
Clear Channel Capability	X				

ACCESS SERVICE

7. Special Access Service (Cont'd)

7.2 Service Descriptions (Cont'd)

7.2.6 High Capacity Service (Cont'd)

(D) Optional Features and Functions (Cont'd)

(4) DIGILINE HC Option Description* (C)

The DIGILINE HC option provides a digital interface between a customer's High Capacity service and a Telephone Company designated Hub wire center terminating in a Digital Access Cross-connect system. The DIGILINE HC option rates are applied in addition to a customer's High Capacity service recurring and non-recurring charges from the Telephone Company designated Hub wire center to the customer's designated premises.

(5) Clear Channel Capability

(a) Clear Channel Capability is an arrangement that allows a customer to transport 1.536 Mbs information rate signals over a 1.544 Mbs High Capacity Channel with no constraint on the quantity or sequence of ones (mark) or zeros (space) bits. The customer signal at the channel interface must conform to Bipolar with Eight Zero substitution (B8ZS) line code as described in Technical Reference TR-NPL-000054 and Technical Reference PUB 62508.

(b) Clear Channel Capability is available on 1.544 Mbs High Capacity Channels only and is subject to the availability of facilities.

(c) This option may be ordered at the same time the 1.544 Mbs high Capacity Service is ordered or it may be ordered as an addition to an existing channel. If this option is ordered on an existing 1.544 High Capacity Channel the customer's service will be temporarily interrupted while this service is added.

(d) This option is provided on a per circuit basis. After a High Capacity Circuit (i.e., 24 channels) has been modified to provide this service, a customer may request Clear Channel Capability on any or all of the channels of that circuit at no additional charge.

	(C)
*Effective June 30, 2023, orders for new Digiline services are no longer permitted. The Telephone Company will continue to provide Digiline pursuant to this section 7.2.6 on any existing Digiline that is in service as of June 30, 2023.	
	(C)

ACCESS SERVICE

7. Special Access Service (Cont'd)

7.2 Service Descriptions (Cont'd)

7.2.6 High Capacity Service (Cont'd)

(D) Optional Features and Functions (Cont'd)

(6) Term Discount Plans (Available in only Rochester, OCN 0121) #

(a) Customers may purchase DS1 or DS3 services with Term Discount Plans ("TDPs"), as described in Section 7.4.8 following. Customers purchasing DS1 or DS3 services with TDP may choose between 18, 36, or 60 month service commitments. The 36 month commitment rate will be no less than a 5% discount from the month to month rate. The 60 month term plan will be no less than a 10% discount from the month to month rate. TDP installation charges will not exceed those installation charges assessed for installation on a month to month service.

(b) For DS1 and DS3 term discount plans in effect or ordered before July 26, 2008, the following provision applies:

Should TDP rates increase during the term of any given plan, the Company will continue to provide those services at the then applicable rate of the plan for the lesser of either the remaining life of the term plan or one year.

(c) Reserved For Future Use (C)

Service Offer is limited. See Footnote on page 7-61

ACCESS SERVICE

7. Special Access Service (Cont'd)

7.2 Service Descriptions (Cont'd)

7.2.6 High Capacity Service (Cont'd)

(D) Optional Features and Functions (Cont'd)

(7) Fiber Loop Diversity

(a) The Fiber Loop Diversity (FLD) option provides for separate fiber protect path to the customer's serving wire center. This option is available where facilities permit. For a list of those locations, see the National Exchange Carrier Association Tariff F.C.C. No. 4.

(b) This option is provisioned solely on a fiber optic ring and offers protection on the channel termination (local loop) portion of a 1.544 Mbps (DS1) service only.

(c) This option may be ordered in conjunction with the installation of a new DS1 service, or it may be ordered as a option to an existing DS1 service. If the FLD option is ordered concurrent with a new DS1 service installation, no additional installation charges apply. If, however, the FLD option is provisioned on an existing DS1 service, the current nonrecurring rate stated in Section 16 following of this Guide will apply.

(d) Unless otherwise requested by the customer, the FLD option and the primary loop will enter the customer premises via the same entrance. The customer may request that the FLD option be provisioned using a separate entrance. If a separate entrance for the FLD option is requested by the customer and additional construction is required by the Telephone Company, then special construction charges will be assessed in accordance with the terms and conditions stated in the applicable Interstate Special Construction Tariff.

(8) Digital Cross Connect

The Digital Cross Connect option provides for a connection between two Telephone Company owned Multiplexers in the same Central Office. A nonrecurring charge, set forth in Section 16 following, is assessed per Digital Cross Connect.

ACCESS SERVICE

7. Special Access Service (Cont'd)

7.2 Service Descriptions (Cont'd)

7.2.6 High Capacity Service (Cont'd)

(D) Optional Features and Functions (Cont'd)

(9) Fractional T-1

(a) Fractional T-1 is an optional feature available as part of the High Capacity Digital Service. The feature provides for the transmission of signals in N x 56 Kbps or N x 64 Kbps, ordered in increments of 2, 3, 4, 5, or 6 DSO channels. Channels must be sequential. Signaling can either be digital or analog, and will handle AMI or B8ZS options. The speeds at which the service may be ordered are as follows:

N x 56

N x 64

2 x 56 = 112 Kbps

2 x 64 = 128 Kbps

3 x 56 = 168 Kbps

3 x 64 = 192 Kbps

4 x 56 = 224 Kbps

4 x 64 = 256 Kbps

5 x 56 = 280 Kbps

5 x 64 = 320 Kbps

6 x 56 = 336 Kbps

6 x 64 = 384 Kbps

(b) Fractional T-1 service is deployed, where available, using a Digital Access Cross-connect System (DACs), or D4-type channel bank located in the Telephone Company central office. The link (local loop) from the customers serving wire center (SWC) to the customers premises must be a 4-wire non-loaded copper facility. The maximum length over which the service may be provided is 12,000 feet from the SWC to the customers premises. Rates for Fractional T-1 service are set forth in Section 16, following.

(c) Interoffice transport, when applicable, will be assessed at the current tariff rate for the type of transport selected (i.e., Digiline, DDS).

ACCESS SERVICE

- 7. Special Access Service (Cont'd)
- 7.2 Service Descriptions (Cont'd)
- 7.2.6 High Capacity Service (Cont'd)
- (D) Optional Features and Functions (Cont'd)
- (10) Enhanced Diversity Management Service
- (a) General

Enhanced Diversity Management Service ("EDMS") is a service option that provides for Telephone Company management of a customer's diverse routing of two or more special access DS1 or DS3 circuits terminating at the same location. The Telephone Company assumes responsibility for the facility assignment and routing of the customer's dedicated circuits over the Telephone Company network. Requests for EDMS service option will be through the standard Access Service Request ("ASR") provisioning process. EDMS service option may be ordered on new service installations as well as existing service. Any Rearrangements required to provide EDMS on existing circuits will be assessed the standard tariff charges as describe in Section 7.4.1(C)(3), following. EDMS is provided at two levels of service, EDMS Level 1 and EDMS Level 2. Any special construction required to provide a particular level of EDMS will be charged to the customer in accordance with the terms and conditions of the applicable Interstate Special Construction Tariff, in addition to standard tariff rates for the High Capacity service ordered under this Guide.

- (b) Service Description

EDMS Level 1

Diversity from the Serving Wire Center ("SWC") serving the Interexchange Carrier ("IXC") to the SWC serving the terminating end of the circuit. Facilities from the IXC POP SWC to the IXC may be common.

ACCESS SERVICE

7. Special Access Service (Cont'd)

7.2 Service Descriptions (Cont'd)

7.2.6 High Capacity Service (Cont'd)

(D) Optional Features and Functions (Cont'd)

(10) Enhanced Diversity Management Service (Cont'd)

(b) Service Description (Cont'd)

EDMS Level 2

Total diversity from the IXC POP to the terminating end of the circuit. Facilities may be through common SWCs, but on physically separate facilities.

(c) Provisioning

The customer will supply diversity requirements to the Telephone Company for an embedded or new customer network. The Telephone Company will determine the routing scheme for the DS1 or DS3 that will take the fullest advantage of the existing Telephone Company network. The design objective will be the complete physical separation of circuits such that route diversity is maintained according to the level of service ordered.

A block diagram of the circuit routing will be provided upon initial installation as well as with any subsequent changes to the circuit. A report will be issued to the customer on a quarterly basis, providing the end user customer name, service type, and circuit identification number of each diverse circuit.

(d) Rates

Recurring and non-recurring charges associated with this service are set forth in Section 16, following. All charges are in addition to the standard tariff rates associated with High Capacity DS1 and DS3 service.

ACCESS SERVICE

7. Special Access Service (Cont'd)

7.3 Channel Interface and Network Channel Codes

This section explains the Channel Interface codes and Network Channel codes that the customer must specify when ordering Special Access Service. Included is an example which explains the specific characters of the code, a glossary of Channel Interface codes, impedance levels, Network Channel codes and compatible Channel Interfaces.

Example: If the customer specifies a NT Network Channel Code and a 2DC8-3 Channel Interface at the customer's premises, the following is being requested:

- NT = Metallic Channel with a Predefined Technical Specification Package (1)
- 2 = Number of physical wires at customer premises
- DC = Facility interface for direct current or voltage
- 8 = Variable impedance level
- 3 = Metallic facilities (DC continuity) for direct current/low frequency control signals or slow speed data (30 baud)

7.3.1 Glossary Channel Interface Codes and Options

<u>Code</u>	<u>Option</u>	<u>Definition</u>
AB	-	accepts 20 Hz ringing signal at customer's point of termination
AC	-	accepts 20 Hz ringing signal at customer's end user's point of termination
CT	-	Centrex Tie Trunk Termination
DA	-	data stream in VF frequency band at customer's end user's point of termination
DB	-	data stream in VF frequency band at customer's point of termination
	- 10	VF for TG1 and TG2
	- 43	VF for 43 Telegraph Carrier type signals, TG1 and TG2
DC	-	direct current or voltage
	- 1	monitoring interface with series RC combination (McCulloh format)
	- 2	Telephone Company energized alarm channel
	- 3	Metallic facilities (DC continuity) for direct Current/low frequency control signals or Slow Speed data (30 baud)
DD	-	DATAPHONE Select-A-Station (and TABS) interface at customer's point of termination
DE	-	DATAPHONE Select-A-Station (and TABS) interface at the customer's end user's point of termination.
DO	-	digital interface at customer's point of termination at the digital signal level zero A (DS-OA)

ACCESS SERVICE

7. Special Access Service (Cont'd)

7.3 Channel Interface and Network Channel Codes (Cont'd)

7.3.1 Glossary Channel Interface Codes and Options (Cont'd)

<u>Code</u>	<u>Option</u>	<u>Definition</u>
DS	-	digital hierarchy interface
	- 15	1.544 mbps (DS1) format per PUB41451 plus D4
	- 15E	8-bit PCM encoded in one 64 kbps of the DS1 signal
	- 15F	8-bit PCM encoded in two 64 kbps of the DS1 signal
	- 15G	8-bit PCM encoded in three 64 kbps of the DS1 signal
	- 15H	14/11-bit PCM encoded in six 64 kbps of the DS1 signal
	- 15J	1.544 mbps format per PUB 41451
	- 27	274.176 mbps (DS4)
	- 27L	274.176 mbps (DS4) with SF signaling
	- 31	3.152 mbps (DS1C)
	- 31L	3.152 mbps(DS1C) with SF signaling
	- 44	44.736 mbps (DS3)
	- 44L	44.736 mbps (DS3) with SF signaling
	- 63	6.313 mbps (DS2)
	- 66L	6.313 mbps (DS2) with SF signaling
DU	-	digital access interface
	- 15S	1.544 mbps format per PUB 41451 plus extended framing format
	- 19	19.2 kbps
	- 24 *	2.4 kbps
	- 48 *	4.8 kbps
	- 56 *	56.0 kbps
	- 64 *	64.0 kbps
	- 96 *	9.6 kbps
	- A	1.544 Mbps format per PUB 41451
	- B	1.544 Mbps format per PUB 41451 plus D4 format
	- C	1.544 Mbps format per PUB 41451 plus extended framing format
	- S	1.544 Mbps (DS1) with B8ZS Clear Channel Capability per Technical
Reference TR-NPL-000054		
DX	-	duplex signaling interface at customer's point of termination
DY	-	duplex signaling interface at customer's end user's point of termination

* Is an additional Telephone Company designation for use when the Optional Secondary Channel feature is required.

ACCESS SERVICE

7. Special Access Service (Cont'd)

7.3 Channel Interface and Network Channel Codes (Cont'd)

7.3.1 Glossary Channel Interface Codes and Options (Cont'd)

<u>Code</u>	<u>Option</u>	<u>Definition</u>
EA	- E	Type I E&M Lead Signaling. Customer at POT or customer's end user at POT originates on E Lead
EA	- M	Type I E&M Lead Signaling. Customer at POT or customer's end user at POT originates on M Lead
EB	- E	Type II E&M Lead Signaling. Customer at POT or customer's end user at POT originates on E Lead
EB	- M	Type II E&M Lead Signaling. Customer at POT or customer's end user at POT originates on M Lead
EC	-	Type III E&M signaling at customer POT
EX	- A	tandem channel unit signaling for loop start or ground start and customer supplies open end (dial tone, etc.) functions
EX	- B	tandem channel unit signaling for loop start or ground start and customer supplies closed end (dial pulsing, etc.) functions.
GO	-	ground start loop signaling open end function by customer or customer's end user
GS	-	ground start loop signaling closed end function by customer or customer's end user
LA	-	E.I.A. (25 pin RS 232)
LA	-	end user loop start loop signaling Type A OPS registered port open end
LB	-	end user loop start loop signaling Type B OPS registered port open end
LC	-	end user loop start signaling Type C OPS registered port open end
LO	-	loop start loop signaling open end function by customer or customer's end user
LR	-	20 Hz automatic ringdown interface at customer with Telephone Company provided PLAR
LS	-	loop start loop signaling closed end function by customer or customer's end user
NO	-	no signaling interface, transmission only

ACCESS SERVICE

7. Special Access Service (Cont'd)

7.3 Channel Interface and Network Channel Codes (Cont'd)

7.3.1 Glossary Channel Interface Codes and Options (Cont'd)

<u>Code</u>	<u>Option</u>	<u>Definition</u>
PG	-	program transmission - no dc signaling
	- 1	nominal frequency from 50 to 15,000 Hz
	- 3	nominal frequency from 200 to 3,500 Hz
	- 5	nominal frequency from 100 to 5,000 Hz
	- 8	nominal frequency from 50 to 8,000 Hz
RV	- 0	reverse battery signaling, one-way operation, originate by customer.
	T	reverse battery signaling, one-way operation, terminate function by customer or customer's end user
SF	-	single frequency signaling with VF band at either customer POT or customer's end user's point of termination
TF	-	telephotograph interface
TT	-	telegraph/teletypewriter interface at either customer POT or customer's end user's point of termination
	- 2	20.0 milliamperes
	- 3	3.0 milliamperes
	- 6	62.5 milliamperes
TV	-	television interface
	- 1	combined (diplexed) video and one audio signal
	- 2	combined (diplexed) video and two audio signals
	- 5	video plus one (or two) audio 5 kHz signal(s) or one (or two) two wire
	- 15	video plus one (or two) audio 15 kHz signal(s)

ACCESS SERVICE

7. Special Access Service (Cont'd)

7.3 Channel Interface and Network Channel Codes (Cont'd)

7.3.2 Impedance

The nominal reference impedance with which the Customer will terminate the channel for the purpose of evaluating transmission performance:

<u>Value (ohms)</u>	<u>Code(s)</u>
110	0
150	1
600	2
900	3
135	5
75	6
124	7
Variable	8
100	9

For those interface codes with a 4 wire transmission path at the customer designated POT, rather than a standard 900 ohm impedance the code (3) denotes a customer provided transmission equipment termination. Such terminations were provided to customers in accordance with the F.C.C. Docket No. 20099 Settlement Agreement.

7.3.3 Digital Hierarchy Channel Interface Codes (4 DSX-*)

Customers selecting multiplexed four-wire DSX-1 or higher capacity interface options at the customer designated premises will be requested to provide subsequent system and channel assignment data. The various digital bit rates in the digital hierarchy employ the channel interface code 4DS9, 4DS0 or 4DS6 plus the speed options indicated below:

<u>Interface Code and Speed Option</u>	<u>Nominal Bit Rate (Mbps)</u>	<u>Digital Hierarchy Level</u>
4DS8-15	1.544	DS1
4DS8-15L	1.544	DS1
4DS6-44	44.736	DS3
4DS6-44L	44.736	DS3

ACCESS SERVICE

7. Special Access Service (Cont'd)

7.3 Channel Interface and Network Channel Codes (Cont'd)

7.3.4 Service Designator/Network Channel Code Conversion Table

The purpose of this table is to show the relationship between the service designator codes (e.g. VGC, MT2, etc.) and the network channel codes that are used for:

<u>Service Designator Code</u>	<u>Network Channel Code</u>
MTC	MQ
MT1	NT
MT2	NU
MT3	NV
TGC	NQ
TG1	NW
TG2	NY
VGC	LQ
VG1	LB
VG2	LC
VG3	LD
VG4	LE
VG5	LF
VG6	LG
VG7	LH
VG8	LJ
VG9	LK
VG10	LN
VG11	LP
VG12	LR
APC	PX
AP1	PE
AP2	PF
AP3	PJ
AP4	PK

ACCESS SERVICE

7. Special Access Service (Cont'd)

7.3 Channel Interface and Network Channel Codes (Cont'd)

7.3.4 Service Designator/Network Channel Code Conversion Table (Cont'd)

<u>Service Designator Code</u>	<u>Network Channel Code</u>
TVC	TX
TV1	TV
TV2	TW
DA1	XA
DA2	XB
DA3	XG
DA4	XH
DA5	XE
DA6	YN
HC1	HC
HC1C	HD
HC2	HE
HC3	HF
HC4	HG

ACCESS SERVICE

7. Special Access Service (Cont'd)

7.3 Channel Interface and Network Channel Codes (Cont'd)

7.3.5 Compatible Channel Interfaces

The following tables show the available channel interface codes (CIs) which are compatible:

(A) Metallic

Compatible CIs

2DC8-1	2DC8-2
2DC8-3	2DC8-3
4DS9-*	2DC8-1
4DS9-*	2DC8-2

(B) Telegraph Grade

Compatible CIs

2DB2-10	10IA2
2DB2-10	2TT2-2
2DB2-10	4TT2-2
2DB2-43+	10IA2
2DB2-43+	2TT2-2
2DB2-43+	2TT2-6
2DB2-43+	4TT2-2
4DB2-10	10IA2
4DB2-10	2TT2-2
4DB2-10	4TT2-2
4DB2-43+	10IA2
4DB2-43+	2TT2-6
4DB2-43+	4TT2-2
4DS9-*	10IA2
4DS9-*	2TT2-2
4DS9-*	4TT2-2
4DS9-*	2TT2-6
4DS9-*	4TT2-6
2TT2-2	2TT2-2
2TT2-3	2TT2-2
2TT2-3	4TT2-2
2TT2-6	4TT2-2
4TT2-2	4TT2-2
4TT2-6	2TT2-6

* See 7.3.3 preceding for explanation.

+ Supplemental Channel Assignment information required.

ACCESS SERVICE

7. Special Access Service (Cont'd)

7.3 Channel Interface and Network Channel Codes (Cont'd)

7.3.5 Compatible Channel Interfaces (Cont'd)

(C) Voice Grade

<u>Compatible CIs</u>		<u>Compatible CIs</u>		<u>Compatible CIs</u>	
4AB2	4AC2	4DS9-*	9DY3	4DS9-*	6LS2
4AB3	4AC2	4DS9-*	4DY2	4DS9-*	4LS2
4AB2	2AC2	4DS9-*	6DY3	4DS9-*	2LS2
4AB3	2AC2	4DS9-*	6DY2	4DS9-*	2LS3
2AB2	2AC2	4DS9-*	4DY2		
2AB3	2AC2	4DS9-*	2DY2	4DS9-*	4NO2
			4DS9-*	2NO2	
4AB2	4SF2	4DS9-*	9EA2		
4AB3	4SF2	4DS9-*	9EA3	4DS9-*	4PR2
		4DS9-*	6EA2-E	4DS9-*	2PR2
6DA2	6DA2	4DS9-*	6EA2-M		
6DA2	4DA2	4DS9-*	4EA2-E	4DS9-*	4SF2
4DA2	4DA2	4DS9-*	4EA2-M	4DS9-*	4SF3
4DB2	6DA2	4DS9-*	8EB2-E	4DS9-*	4TF2
4DB2	4DA2	4DS9-*	8EB2-M	4DS9-*	2TF2
4DB2	2DA2	4DS9-*	6EB2-E		
2DB3	2DA2	4DS9-*	6EB2-M	6DX2	4SF2
2DB2	2DA2			4DX2	4SF2
		4DS9-*	2GO2	4DX3	4SF2
4DB2	4NO2			4DX2	4SF3
4DB2	2NO2	4DS9-*	6GS2	4DX3	4SF3
2DB2	2NO2	4DS9-*	4GS2		
		4DS9-*	2GS2	9EA3	4SF2
4DD3	4DE2	4DS9-*	2GS3	9EA2	4SF2
4DD3	2DE2			6EA2-E	4SF3
		4DS9-*	2LA2	6EA2-M	4SF3
4DS9-*	4AC2			6EA2-E	4SF2
4DS9-*	2AC2	4DS9-*	2LB2	6EA2-M	4SF2
			6EA3-E	4SF2	
4DS9-*	6DA2	4DS9-*	2LC2	4EA2-E	4SF2
4DS9-*	4DA2			4EA2-M	4SF2
4DS9-*	2DA2	4DS9-*	2LO2		
		4DS9-*	2LO3	8EB2-E	4SF2
4DS9-*	4DE2	8EB2-M	4SF2		
4DS9-*	2DE2	4DS9-*	4LR2	8EB2-E	4SF3
		4DS9-*	2LR2	8EB2-M	4SF3
4DS9-*	4DX3	6EB3-E	4SF2		
4DS9-*	4DX2	6EB2-E	4SF2	6EB2-M	4SF2

* See 7.3.3 preceding for explanation.

ACCESS SERVICE

7. Special Access Service (Cont'd)

7.3 Channel Interface and Network Channel Codes (Cont'd)

7.3.5 Compatible Channel Interfaces (Cont'd)

(C) Voice Grade (Cont'd)

Compatible CIs

6EX2-A	4SF2
6EX2-B	4SF2
6GO2	4SF2
4GO2	4SF2
4GO3	4SF2
6LO2	4SF2
4LO2	4SF2
4LO3	4SF2
4LR2	4SF2
4LR3	4SF2
4SF2	4AC2
4SF2	2AC2

4SF3	9EA2
4SF3	9EA3
4SF3	9EA2-E
4SF3	4EA2-M
4SF3	6EB2-E
4SF3	6EB2-M

4SF3	6GS2
4SF2	6GS2
4SF2	4GS2
4SF3	4GS2
4SF2	2GS2
4SF2	2GS3
4SF3	2GS2
4SF3	2GS3

4SF3	4SF3
4SF3	4SF2
4SF2	4SF2
4TF2	4TF2
4TF2	2TF2
2TF3	2TF2

ACCESS SERVICE

7. Special Access Service (Cont'd)

7.3 Channel Interface and Network Channel Codes (Cont'd)

7.3.5 Compatible Channel Interfaces (Cont'd)

(D) Program Audio

Compatible CIs

2PG2-1	2PG1-1
2PG2-1	2PG2-1
2PG2-3	2PG1-3
2PG2-3	2PG2-3
2PG2-5	2PG1-5
2PG2-5	2PG2-5
2PG2-8	2PG1-8
2PG2-8	2PG2-8

(E) Video

Compatible CIs

2TV6-1	4TV6-15
2TV6-1	4TV7-15
2TV7-1	4TV6-15
2TV7-1	4TV7-15
4TV6-15	4TV6-15
4TV6-15	4TV7-15
4TV7-15	4TV6-15
4TV7-15	4TV7-15

ACCESS SERVICE

7. Special Access Service (Cont'd)

7.3 Channel Interface and Network Channel Codes (Cont'd)

7.3.5 Compatible Channel Interfaces (Cont'd)

(F) Digital Data

<u>Compatible CIs</u>		<u>Compatible CIs</u>		<u>Compatible CIs</u>	
4AB2	4AC2	4DS9-*	9DY3	4DS9-*	6LS2
4DS8-15*	4DU5-24*#	4DS8-15*#	6DU5-56*#	4DU5-96*#	4DU5-96*#
4DS8-15*	4DU5-48*#	4DS8-15*#	6DU5-96*#	6DU5-24*#	6DU5-24*#
4DS8-15*	4DU5-56*#	4DU5-24*#	4DU5-24*#	6DU5-48*#	6DU5-48*#
4DS8-15*	4DU5-96*#	4DU5-48*#	4DU5-48*#	6DU5-56*#	6DU5-56*#
4DS8-15*	6DU5-24*#	4DU5-56*#	4DU8-56*#	6DU5-96*#	6DU5-96*#
4DS8-15*	6DU5-48*#				
4DS8-15	4DU5-19#				
4DS8-15	4DU5-64#				
4DS5-19	4DU5-19#				
4DS8-64	4DU5-64#				

(G) High Capacity

<u>Compatible CIs</u>		<u>Compatible CIs</u>	
4DS0-63	4DS0-63	4DS8-15	8DU8-B7
4DS0-63*	6DU8-A,B or C	4DS8-15J	6DU8-A
4DS0-63*	8DU8-A,B or C	4DS8-15J	8DU8-A
4DS6-27	4DS6-27	4DS8-15K	6DU8-B
4DS6-27*	6DU8-A,B or C	4DS8-15K	8DU8-B
4DS6-27*	8DU8-A,B or C	4DS8-15K	6DU8-C
4DS6-44	4DS6-44	4DS8-15K	8DU8-C
4DS6-44*	6DU8-A,B or C	4DS8-15S	8DU8-S
4DS6-44*	8DU8-A,B or C	4DS8-31	4DS8-31
4DS8-15	6DU8-B	4DS8-31*	6DU8-A,B or C
		4DS8-31*	8DU8-A,B or C
		4DS9-15*	4DU9-BN

* Available to customers selecting the multiplexed 4 wire DSX channel interface option and providing subsequent system and channel assignment data.

Is an additional Telephone Company designation for use when the Optional Secondary Channel feature is required.

ACCESS SERVICE

7. Special Access Service (Cont'd)

7.4 Rate Regulations

This section contains the specific regulations governing the rates and charges that apply for Special Access Service.

7.4.1 Types of Rates and Charges

There are three types of rates and charges. These are monthly rates, daily rates and nonrecurring charges. The rates and charges are described as follows:

(A) Monthly Rates

Monthly rates are flat recurring rates that apply to each month or fraction thereof that a Special Access Service is provided. For billing purposes, each month is considered to have 30 days.

(B) Daily Rates

Daily rates are flat recurring rates that apply to each 24 hour period or fraction thereof that a Program Audio or Video Special Access Service is provided for part-time or occasional use. For purposes of applying daily rates, the 24 hour period is not limited to a calendar day. The maximum rate charged to a customer will be the daily rate for each of the first two days of service plus 1/30 of the monthly rate for each additional day within a 30 day period.

(C) Nonrecurring Charges

Nonrecurring charges are one-time charges that apply for a specific work activity (i.e., installation or change to an existing service). The types of nonrecurring charges that apply for Special Access Service are: installation of service, installation of optional feature(s) and function(s), service rearrangements and discontinuance of service. (C)

(1) Installation of Service

Nonrecurring charges apply to each service installed. The nonrecurring charges for the installation of service are set forth in Section 16 following as a nonrecurring charge for the Channel Termination rate element.

ACCESS SERVICE

7. Special Access Service (Cont'd)

7.4 Rate Regulations (Cont'd)

7.4.1 Types of Rates and Charges (Cont'd)

(C) Nonrecurring Charges (Cont'd)

(2) Installation of Optional Features and Functions

Nonrecurring charges apply for the installation of optional features and functions available with Special Access Service. The charge applies whether the feature or function is installed coincident with the installation of service or at any time subsequent to the initial installation of service.

(3) Service Rearrangements

All changes to existing services will be treated as the discontinuance of the existing service and an installation of new service, except for: changes involving the addition of optional features and functions having specific nonrecurring charges; changes involving administrative activities only; or an addition to a multipoint service. An existing service is one which has been installed and does not include services which have been ordered and not yet installed. The nonrecurring charge described in (1) preceding will apply for this work activity. If the change involves the addition of other customer designated premises to an existing multipoint service, the nonrecurring charge(s) will apply only to the location(s) being added. Moves that change the physical location of the point of termination are described in 7.4.4 following.

(4) Discontinuance Non-Recurring Charge (C)

In addition to any other charges associated with discontinuance of services, the Telephone Company will charge a discontinuance non-recurring charge to discontinue services. This charge applies on a per circuit basis. Refer to the applicable discontinuance non-recurring charges as listed in section 16. In addition to the discontinuance non-recurring charge, minimum service period charges and early termination liability may apply if the circuit term or minimum service period has not been met.

(C)

ACCESS SERVICE

7. Special Access Service (Cont'd)

7.4 Rate Regulations (Cont'd)

7.4.1 Types of Rates and Charges (Cont'd)

(C) Nonrecurring Charges (Cont'd)

(3) Service Rearrangements (Cont'd)

Administrative changes will be made without charge(s) to the customer. Administrative changes are as follows:

- Change of customer name,
- Change of customer or customer's end user premises address when the change of address is not a result of a physical relocation of equipment,
- Change in billing data (name, address, or contact name or telephone number),
- Change of agency authorization,
- Change of customer circuit identification,
- Change of billing account number,
- Change of customer test line number,
- Change of customer or customer's end user contact name or telephone number, and
- Change of jurisdiction.

7.4.2 Surcharge for Special Access Service

(A) General

Special access services provided under this Guide may be subject to the monthly Special Access Surcharge.

(B) Application

(1) The Special Access Surcharge will apply to each interstate Special Access Service (e.g. Voice Grade Service) that terminates on an end user's PBX or other device where, through a function of the device, the Special Access Service interconnects to the local exchange network. Interconnection functions include but are not limited to wiring and software functions, bridging, switching or patching of calls or stations. The Surcharge will apply irrespective of whether the interconnection function is performed in equipment located at the customer's premises or in a Centrex Co-type switch.

ACCESS SERVICE

7. Special Access Service (Cont'd)

7.4 Rate Regulations (Cont'd)

7.4.2 Surcharge for Special Access Service (Cont'd)

(B) Application (Cont'd)

(2) Special Access Service will be exempted from the Surcharge by the Telephone Company upon receipt of the Customer's written certification for the following Special Access Service terminations:

- (a) an open-end termination in a Telephone Company switch of an FX line, including CCSA and CCSA-equivalent ONALs; or
 - (b) an analog channel termination that is used for radio or television program transmission; or
 - (c) a termination used for TELEX service; or
 - (d) a termination that by the nature of its operating characteristics could not make use of Telephone Company common lines such as, terminations which are restricted through hardware or software; or
 - (e) a termination that interconnects either directly or indirectly to the local exchange network where the usage is subject to Carrier Common Line charges such as, where the Special Access Service accesses only FGA and no local exchange lines, or Special Access Service between customer points of termination, or Special Access Service connecting CCSA or CCSA-type equipment (inter-machine trunks); or
 - (f) a termination that the customer certifies to the Telephone Company is not connected to a PBX or other device which interconnects the Special Access Service to a local exchange subscriber line.
-

ACCESS SERVICE

7. Special Access Service (Cont'd)

7.4 Rate Regulations (Cont'd)

7.4.2 Surcharge for Special Access Service (Cont'd)

(C) Exemption of Special Access Service

(1) Special Access Services which are terminated as set forth in 7.4.2 (B) preceding will be exempted from the Special Access Surcharge if the customer provides the Telephone Company with written exemption certification. The Certification may be provided to the Telephone Company (1) at the time the Special Access Service is ordered or installed; (2) at such time as the service is terminated to a device which does not interconnect to the special access service to a local exchange subscriber line, or (3) at such time as the service becomes associated with a Switched Access Service that is subject to Carrier Common Line charges.

(2) The exemption certification is to be provided by the customer ordering the service. The certification must be signed by the customer or authorized representative and include the category of exemption, as set forth in 7.4.2.(B) preceding, for each termination, and the date which the exemption is effective.

(3) The customer shall also notify the Telephone Company when an exempted Special Access Service is changed or terminated such that the exemption is no longer applicable.

(4) The Telephone Company will work cooperatively with the customer to resolve any questions regarding the exemption certification. However, the Telephone Company reserves the right to request additional information from the customer, when necessary, to assure qualifications for exemption of the surcharge are met. In addition, the Telephone Company may withhold exemption of the service until the dispute is resolved.

ACCESS SERVICE

7. Special Access Service (Cont'd)

7.4 Rate Regulations (Cont'd)

7.4.2 Surcharge for Special Access Service (Cont'd)

(D) Rate Regulations

(1) The Surcharge applies to each channel of a Special Access Service and per voice grade equivalent service derived from a Special Access Service as shown in the following example:

Special Access Service	Voice Grade Equivalent		Surcharge	Monthly Charge
DS1	24	X	\$25	= \$600.00

One Surcharge will apply for each termination of a multipoint Special Access Service at a customer's designated premises minus one.

(2) The Telephone Company will bill the appropriate Special Access Surcharge to the ordering customer for each interstate Special Access Service installed unless exemption certification is provided as set forth in 7.4.2 (C) preceding.

(3) If a written certification is not received at the time the Special Access Service is obtained, the Surcharge will be applied. Exempt status will become effective on the certification date indicated by the customer, subject to the regulations set forth in (4) following.

(4) The Telephone Company will cease billing the Special Access Surcharge when certification, as set forth in 7.4.2(C) preceding, is received. If the status of the Special Access Service was changed prior to receipt of the exemption certification, the Telephone Company will credit the customer's account, not to exceed ninety (90) days, based on the effective date of the change as specified by the customer in the letter of certification.

(5) Rates for the Surcharge for Special Access are set forth in Section 16, following.

ACCESS SERVICE

7. Special Access Service (Cont'd)

7.4 Rate Regulations (Cont'd)

7.4.3 Minimum Periods

The minimum service period for all services except part-time and occasional Video and Program Audio and Term Discount Plan services is one month.

The minimum service period for part-time and occasional Video and Program Audio services is one day (i.e., a continuous 24-hour period, not limited to a calendar day).

The minimum service period for Term Discount Plan (TDP) services is the length of the specified TDP.

7.4.4 Moves

A move involves a change in the physical location of either a point of termination at a customer premises or a customer's premises. The charges for the move are dependent on whether the move is to a new location within the same building or to a different building.

(A) Moves Within the Same Building

When the move is to a new location within the same building, the charge for the move will be an amount equal to one half of the nonrecurring (i.e., installation) charge for the service termination affected. There will be no change in the minimum period requirements.

(B) Moves To a Different Building

Moves to a different building will be treated as a discontinuance and start of service and all associated nonrecurring charges will apply. New minimum period requirements will be established for the new services. The customer will also remain responsible for satisfying all outstanding minimum period charges for the discontinued service.

ACCESS SERVICE

7. Special Access Service (Cont'd)

7.4 Rate Regulations (Cont'd)

7.4.5 Mileage Measurement

The mileage to be used to determine the monthly rate for the Channel Mileage is calculated on the airline distance between the locations involved, i.e., the serving wire centers associated with two customer designated premises, a serving wire center associated with a customer designated premises and a Telephone Company Hub, two Telephone Company Hubs, or between the serving wire center associated with a customer designated premises and a WATS serving office. The serving wire center associated with a customer designated premises is the serving wire center from which this customer designated premises would normally obtain dial tone.

When Hubs are involved, mileage is computed and rates applied separately for each section of the Channel Mileage, i.e., customer designated premises serving wire center to Hub, Hub to Hub and/or Hub to customer designated premises serving wire center. However, when any service is routed through a Hub for purposes other than customer specified bridging or multiplexing (e.g., the Telephone Company chooses to so route for test access purposes), rates will be applied only to the distance calculated between the serving wire centers associated with the customer designated premises.

Mileage used to determine the billing of mileage sensitive rates is computed using the V&H coordinates method as set forth in the National Exchange Carrier Association Tariff F.C.C. No. 4. When the mileage calculation results in a fraction of the specified unit, it is rounded up as follows:

For rates specified as per mile, calculations resulting in a fraction of a mile are rounded up to the next whole mile to determine billable mileage.

For rates specified as units of greater than one mile (e.g., Program Audio Service), calculations resulting in a fraction of the specified unit are rounded up to the next whole specified unit to determine billable mileage.

When a meet point billing situation is involved, the mileage is calculated as described above, then multiplied by the appropriate mileage sensitive rate and the appropriate bill percentage from the National Exchange Carrier Association Tariff F.C.C. No. 4 to determine the dollar amount billed.

ACCESS SERVICE

7. Special Access Service (Cont'd)

7.4 Rate Regulations (Cont'd)

7.4.6 Facility Hubs

A customer has the option of ordering analog or digital high capacity facilities (i.e., Group, Supergroup, Mastergroup, DS1, DS1C, DS2, DS3 or DS4) to a facility Hub for channelizing to individual services requiring lower capacity facilities (e.g., Telegraph Voice, Program Audio, etc.).

Different locations may be designated as Hubs for different facility capacities, e.g., multiplexing from digital to digital may occur at one location while multiplexing from digital to analog may occur at a different location. Specific hub location information is incorporated in Exchange Carrier Association Tariff F.C.C. No. 4.

Some of the types of multiplexing available include the following:

- from higher to lower bit rate
- from higher to lower bandwidth
- from digital to voice frequency channels

End to end services may be provided on channels of these facilities to a Hub. The transmission performance for the end to end service provided between the customer designated premises will be that of the lower capacity or bit rate. For example, when a 1.544 Mbps service is multiplexed to voice frequency channels, the transmission performance of the channelized services will be Voice Grade, not High Capacity.

The Telephone Company will commence billing the monthly rate for the facility to the Hub on the date specified by the customer on the service order. Individual services utilizing these facilities may be installed coincident with the installation of the facility to the Hub or may be ordered and/or installed at a later date, at the option of the customer. The customer will be billed for a high capacity analog or digital Channel Termination, Channel Mileage (when applicable), and the multiplexer at the time the facility is installed. Individual service rates (by service type) will apply for the Channel Termination and additional Channel Mileage (as required) for each channelized service. These will be billed to the customer as each individual service is installed.

Cascading multiplexing occurs when a high capacity channel is de-multiplexed to provide channels with a lesser capacity and one of the lesser capacity channels is further de-multiplexed. For example, a Supergroup facility is de-multiplexed to five Group facilities and then one of the Group facilities is further de-multiplexed to individual voice grade channels.

ACCESS SERVICE

7. Special Access Service (Cont'd)

7.4 Rate Regulations (Cont'd)

7.4.6 Facility Hubs (Cont'd)

When cascading multiplexing is performed in the same Hub, a charge for the additional multiplexing unit and the channel interface charge for the resulting lower capacity channel apply. When cascading multiplexing is performed at different hubbing locations Channel Mileage also applies between the Hubs.

Although not requiring multiplexing, the Telephone Company will designate certain Hubs for Video and Program Audio Services. Full-time service will be provided between a customer designated premises and a Hub and billed accordingly at the monthly rates set forth in Section 16 following for a Channel Termination, Optional Features and Functions, and Channel Mileage, as applicable. The customer may order part-time and occasional Video and Program Audio services as needed between a Hub and a second customer designated premises. The rate elements required to provide the part-time or occasional service (i.e., Channel Termination, Optional Features and Functions, and Channel Mileage, as applicable) will be billed at daily rates for the duration of the service requested.

ACCESS SERVICE

7. Special Access Service (Cont'd)

7.4 Rate Regulations (Cont'd)

7.4.7 Shared Use Digital High Capacity Services

Shared use occurs when Special Access Service and Switched Access Service are provided over the same High Capacity (i.e., 1.544 Mbps or 45 Mbps) facility through a common interface. The facility will be ordered, provided and rated as Special Access Service (i.e., Channel Termination, Channel Mileage, as appropriate and Multiplexer). The nonrecurring charge that applies when the shared use facility is installed will be the nonrecurring charge associated with the appropriate Special Access Termination (i.e., 1.544 Mbps or 45 Mbps) and if applicable, the nonrecurring charge for the DS3 to DS1 multiplexer.

Rating as Special Access will continue until such time as the customer chooses to use a portion of the available capacity for providing Switched Access Service. As each individual channel is activated for Switched Access Service, the Special Access Channel Termination and Channel Mileage rates will be reduced accordingly (i.e., 1/24th for a DS1 service and 1/672nd for a DS3 service). The customer must place an order for each individual Switched or Special Access Service utilizing the Shared Use Facilities and specify the channel assignment for each such service.

Switched Access Service rates set forth in FCC 2 Section 16 following will apply for each channel of (T) the shared use facility that is used to provide a Switched Access Service. Where Special Access Service is provided utilizing a channel of the shared use facility to a Hub, high capacity rates and charges will apply or the facility to the Hub as set forth preceding and individual service rates and charges will apply from the Hub to the customer designated premises. The rates and charges that will apply to the portion from the Hub to the customer designated premises will be dependent on the specific type of Special Access Service that is provided (e.g., Voice Grade, Telegraph, etc.). The applicable rates and charges will include a Channel Termination and Channel Mileage (if applicable). Rates and charges for optional features and functions associated with the service, if any, will apply as set forth in Section 16, following.

ACCESS SERVICE

7. Special Access Service (Cont'd)

7.4 Rate Regulations (Cont'd)

7.4.8 Term Discount Plans # (C)

Term Discount Plans (“TDPs”) offer reduced rates to customers who commit to purchase service for a specified period of time. The length of the available TDPs may vary by type of service.

A customer with a service purchased under a month to month agreement may convert that service to a TDP. A customer may convert an existing TDP service to a longer period TDP service. Upon converting an existing service to a TDP or an existing plan to a longer term plan, the customer’s existing application contract obligation will be deemed satisfied and a new term plan will be initiated. No service credit will apply towards the new plan; the new TDP service will be treated as a new service and subject to the full rate and contract obligations of the new TDP service, with the exception that nonrecurring charges do not apply.

A customer who discontinues a service under a TDP prior to the end of the term may, without penalty, transfer the remaining months of the term commitment to a new like service which has been installed within 90 days prior to the disconnection of the service under the original TDP. The new service must connect the customer and the end user entirely over the Telephone Company’s facilities.

Upon expiration of a TDP, the service will convert to the Month to Month rate. (C)

(D)

Effective November 19, 2021, Term Discount Plans are no longer permitted. Term Discount Plans (N) in effect as of November 19, 2021 may continue the existing term but will not be eligible to extend, renew, reenroll in, convert to a new term period, or in any other way continue their existing plan beyond its current expiration. At expiration of the term period, the service will convert to the Month to Month Rate. If at any time an existing customer terminates its Term Discount Plan, the customer may not re-subscribe to the plan.

ACCESS SERVICE

7. Special Access Service (Cont'd)

7.4 Rate Regulations (Cont'd)

7.4.8 Term Discount Plans (Cont'd) # (C)

Customers purchasing TDPs commit to keep a service for the duration of the chosen plan period. If a customer chooses to discontinue the service prior to the duration of a chosen plan period, that customer is liable for a termination charge.

(A) For TDPs ordered after August 27, 2009, the termination liability equals the remaining monthly charges for the term commitment period applied at the rates in effect on the termination date.

(B) For TDPs in effect or ordered before August 27, 2009, the termination liability is computed as follows: The amount of the termination charge is determined in two ways as set forth in (1) and (2) following. The method which provides the customer with the lowest termination liability will be applied.

(1) Method 1

The termination liability equals a one-time charge of 75% of the payments remaining under the chosen plan.

(2) Method 2

Where there exists a TDP period less than the actual time the service has been in effect, the termination charge will be the difference between the rate for the longest TDP period that could have been satisfied prior to discontinuation of service and the rate for the contracted plan period multiplied by the actual number of months the service has been in effect. For example, if a service under a 60 month TDP is discontinued after 40 months, the highest plan period that could have been satisfied is 36 months. The termination charge is the 36 month TDP rate less the 60 month TDP rate multiplied by 40.

Where the actual time the service was in effect is less than the shortest TDP period, the month-to-month rate will be used. For example, if a service under the 36 month TDP is discontinued after 10 months, which is less than the shortest TPD period of 18 months at present, the termination charge will be the month-to-month rate less the 36 month TDP rate multiplied by 10.

Service Offer is limited. See Footnote on page 7-61. (N)

ACCESS SERVICE

7. Special Access Service (Cont'd)

7.5 Expanded Interconnection Service

7.5.1 General

Expanded Interconnection Service is an interstate service offering which allows customers to interconnect with Telephone Company Special Access facilities and services by means of either Physical (interconnector equipment is physically located in Telephone Company central office), or Virtual (interconnector equipment is located outside of Telephone Company central offices), connection. Unless otherwise stated, all terms, conditions and rates contained in this Guide are in reference to Physical collocation of interconnectors equipment and facilities.

7.5.2 Service Description

Expanded Interconnection service provides for the interconnection of Telephone Company provided loop facilities and other Company provided facilities and services to interconnect to provided fiber optic facilities. An interconnector is a customer who provides fiber-optic facilities through Telephone Company entrance manholes for connection to interconnector equipment located in a Telephone Company's central office. If space constraints in a central office prohibit the physical location of interconnector equipment the Telephone Company will designate the nearest connection point outside the central office for connection to the interconnector's equipment and facilities. Such facilities will be used solely for the carriage of interstate special access service.

The Telephone Company will provide interconnection to the following facilities and services:

- 1.544 Mbps Service
- 45 Mbps Service
- Microwave

The Telephone Company will provide two points of entry to interconnectors in those central office where the Telephone Company utilizes two points of entry for its own services.

This service is subject to the availability of space and facilities in each central office where a bona fide request for Special Access Expanded Interconnection is received.

ACCESS SERVICE

7. Special Access Service (Cont'd)

7.5 Expanded Interconnection Service (Cont'd)

7.5.2 Service Description (Cont'd)

(A) Service Availability

(1) Subject to availability of space, this service will be provided to interconnectors on a first come, first served basis. Upon receipt of a bona fide request, including letters of agency for ordering and billing purposes, from an interconnector for interconnection in a Telephone Company central office, the Telephone Company will survey the central office to determine which form of interconnection is available in that particular central office. The survey and its results will be communicated to the interconnector in a reasonable time frame. In those instances where space becomes a limited resource, the Telephone Company reserves the right to petition the Commission for approval of any allocation plan necessary to accommodate bona fide interconnectors.

(a) The Telephone Company will provide interconnectors with at least 180 days to satisfy the requirement that floor space be efficiently used.

(b) The Telephone Company will make reasonable efforts to provide contiguous space when the interconnector requires it for expansion.

(2) The minimum floor space allocated per interconnector will be 100 square feet per central office. This rate is a nonrecurring charge. Additional space may be requested on an as needed basis and will be made available where feasible. An interconnector may request additional space in increments of 100 square feet in the same central office. Upon request for additional contiguous 100 square feet of central office floor space will be filed in this Guide.

(a) The interconnector will be required to pay a \$7,500 deposit when it places its firm order. This deposit will be applied to the total central office Build Out nonrecurring charge.

(3) Upon request, cage access in increments other than 100 square feet may be negotiated on an individual case basis and will be filed in this Guide and made generally available.

(4) Power delivery provides for delivery of the Telephone Company DC power to one node. The rate is a nonrecurring charge.

ACCESS SERVICE

7. Special Access Service (Cont'd)

7.5 Expanded Interconnection Service (Cont'd)

7.5.2 Service Description (Cont'd)

(B) Obligation of The Telephone Company

(1) The Telephone Company will permit the interconnector to establish a "multiplexing node" at the specified Telephone Company central office to which the interconnector constructs fiber optic interconnection cable(s). That multiplexing node will be the location where the following interconnector's equipment is located within the Telephone Company central office.

- (a) Optical Line Terminating Multiplexers (OLTM)
- (b) DS3 to DS1 and DS1 to DS0 Multiplexers
- (c) Digital Cross-Connect Systems (DACs)

(2) The Telephone Company will provide the interconnector with the central office environmental and transmission standards in effect at the time of installation.

(3) The Telephone Company will designate the floor space within each central office which will constitute the multiplexing node. The Telephone Company may, at the interconnector's expense, at rates specified or to be specified in this Guide enclose the interconnector's multiplexing node in a cage or room. The interconnector may locate in its space any central office equipment needed to terminate basic transmission facilities, including optical terminating equipment and multiplexers.

(4) The Telephone Company will respond to requests for interconnection within thirty (30) days of receipt of a written request. If the Telephone Company determines that space is available, it shall complete all necessary site preparation work to permit the interconnector to occupy such space within six (6) months of such determination.

ACCESS SERVICE

7. Special Access Service (Cont'd)

7.5 Expanded Interconnection Service (Cont'd)

7.5.2 Service Description (Cont'd)

(B) Obligation of The Telephone Company (Cont'd)

(5) In addition to the floor space, the Telephone Company will provide DC power, battery and generator back-up power and environmental support to the interconnector's equipment in the same manner that it provides such support items to its own equipment within the central office. Terms, conditions, and rates for these services will be specified in individual agreements between the Telephone Company and the interconnector on an office-by-office basis. Recurring rates for these services (by office) may be found in Section 16 following. The Telephone Company will file such agreements in this Guide.

(6) The Telephone Company will permit the interconnector's employees, agents and contractors approved by the Telephone Company (such approval will not be reasonably withheld) to have access, at all times, to the areas where the interconnector's multiplexing node is located. The interconnector's employees, agents and contractors must comply with the policies and practices of the Telephone Company pertaining to fire, safety and security.

(7) The Telephone Company and/or vendors employed by the Telephone Company will install and repair the fiber optic cable(s) between the manhole and the multiplexing node at the interconnector's expense. This support will be provided in a timely and efficient manner consistent with the Telephone Company's treatment of its own facilities. The Telephone Company will absorb any costs related to troubles which it has caused.

(8) The Telephone Company will designate DSX panels or distribution blocks as the point of termination (POT) within each central office as the point of physical demarcation between the interconnector's services and the Telephone Company's services. The Telephone Company will be responsible for all maintenance and related activities on the Telephone Company side of the POT.

ACCESS SERVICE

7. Special Access Service (Cont'd)

7.5 Expanded Interconnection Service (Cont'd)

7.5.2 Service Description (Cont'd)

(B) Obligation of The Telephone Company (Cont'd)

(9) The Telephone Company will, where reasonably feasible, provide Microwave Interconnection upon bonafide requests. Each instance will be negotiated on an Individual Case Basis and will be filed in this Guide and made generally available.

The Telephone Company and/or vendors employed by the Telephone Company will supply, install, and repair, at interconnector's expense, at rates specified or to be specified in this Guide, all cables, racks, and central office termination equipment necessary to provide the interface required for connection to the Telephone Company's network between the POT and the multiplexing mode.

(10) The Telephone Company will not terminate the interconnector's service for violating a tariff provision unless the interconnector has been given notice and an opportunity to cure the violator.

If an initial interconnector has paid a nonrecurring charge for an asset and is succeeded by another interconnector who uses that asset, the initial interconnector will be credited the remaining undepreciated amount of the equipment and the cage construction cost upon occupancy by the subsequent interconnector;

(a) The subsequent interconnector will be responsible for paying the remaining undepreciated amount of the cost.

ACCESS SERVICE

7. Special Access Service (Cont'd)

7.5 Expanded Interconnection Service (Cont'd)

7.5.2 Service Description (Cont'd)

(B) Obligation of The Telephone Company (Cont'd)

(11) In the event of a catastrophic loss, resulting in damages to the central office and the physical collocation spare, the Telephone Company will inform interconnectors of plans to rebuild as soon as is practicable and the Telephone Company will restore service to interconnectors as soon as possible.

If the Telephone Company uses an asset for which an interconnector paid a nonrecurring charge, the Telephone Company will make a pro rate refund to the interconnector.

(a) The pro rate refund will be based on the life of the equipment and interconnectors specific construction on the economic life of the equipment and the cage.

(12) If the Telephone Company reasonably relocates an interconnector to another central office, the Telephone Company will make all reasonable efforts to minimize disruption of the interconnector's service.

(a) If the Telephone Company relocates interconnectors to either a central office at a new location or to a new location within the central office for reasons other than an emergency, the Telephone Company will provide interconnection with at least 180 days' advance written notice.

ACCESS SERVICE

7. Special Access Service (Cont'd)

7.5 Expanded Interconnection Service (Cont'd)

7.5.2 Service Description (Cont'd)

(C) Obligation of The Interconnector

(1) The interconnector will be responsible for installing, maintaining, repairing and servicing its equipment located in the central office multiplexing node.

(2) The interconnector will be responsible for supplying the fiber optic cable(s) from the manhole to the multiplexing node.

(3) The interconnector will be responsible for any non-recurring costs incurred by the Telephone Company.

(a) If an interconnector withdraws a request for physical collocation, the interconnector will only be responsible for those amounts already expended on its behalf.

(4) Interconnectors shall maintain, at its sole cost and expense, insurance specified below. Such insurance shall be underwritten by insurance companies licensed to do business in the State of New York and shall name the Telephone Company as an additional insured and loss payee.

(a) Comprehensive general liability coverage on per occurrence basis in the amount of \$3 million combined single limit for bodily injury and property damage.

(b) Umbrella/Excess Liability coverage in an amount of \$5 million.

(c) All Risk Property coverage on a full replacement cost basis insuring all of interconnector's real and personal property situated on or within the Telephone Company's location(s).

(d) Statutory Workers Compensation and Employers Liability coverage in an amount of \$2 million.

(e) Auto liability insurance with at least a \$3 million bodily injury and property damage combined single limit.

ACCESS SERVICE

7. Special Access Service (Cont'd)

7.5 Expanded Interconnection Service (Cont'd)

7.5.3 Types of Charges

(A) Cross-Connect

A cross-connect charge will be charged on a monthly basis to recover the costs of the facilities and equipment required for the cable connection from the Telephone Company distribution frame to the central office electronic equipment owned or dedicated to the interconnector. Rates will be standard for each Telephone Company central office where an interconnector has established a multiplexing node. Rates may be found in Section 16 following.

(B) Connection Charge

Connection charges may reasonably differ by central office due to variations in costs. These charges recover the costs for central office space usage under physical collocation. Other such costs recovered by connection charges are, power, environmental conditioning, and use of riser and conduit space. These charges are set forth in Section 16 following, for each central office in which a cross-connect rate element is being assessed to an interconnector in a given central office. If an interconnector has established a multiplexing node via the Telephone Company Intrastate interconnect tariff, and is currently being assessed connection charges from that tariff and is requesting interstate special access interconnection service, only the cross-connect charges will be assessed from this Guide.

ACCESS SERVICE

8. Advanced Communications Services

8.1 SONET Special Access Service

8.1.1 Service Description

This section contains the rules and regulations pertaining to the provision of Synchronous Optical Network (SONET) service. SONET is the North American standard for the transmission of high capacity bandwidth over optical facilities. This synchronous transmission platform utilizes a modular multiplexing approach. Because of the large bandwidth, some of the payload is used to monitor, protect, manage, and improve the transmission of the signal.

SONET services are differentiated by bit rate of the backbone transmission path. The Telephone Company offers SONET services at the following transmission speeds:

- OC-3 Service provides transmission at the bit rate of 155.52 Mbps
- OC-12 Service provides transmission at the bit rate of 622.08 Mbps
- OC-48 Service provides transmission at the bit rate of 2488.32 Mbps

SONET service consists of nodes, ports, links, and interoffice mileage. Within point to point SONET service, the same payload content is maintained throughout the transmission path, i.e. if DS1s are mapped at one end they must also be mapped at the other end.

8.1.2 SONET Node

SONET Service provides connectivity to two or more customer-designated locations, or nodes. Nodes may be located in Telephone Company central offices or at customer premises. The Telephone Company reserves the right to limit the number of nodes on any SONET arrangement based on engineering considerations.

A SONET Node can function as an add/drop multiplexer for the underlying SONET transmission service, and can also function as the end point of a SONET transmission channel. To use the add/drop multiplexer function, the customer must also purchase the appropriate port(s) at the desired node.

Each SONET Node represents transmission capacity specific to the ordered SONET service. However, the Telephone Company does not guarantee the use of equipment specifically dedicated to any individual customer.

ACCESS SERVICE

8. Advanced Communications Services (Cont'd)

8.1 SONET Special Access Service (Cont'd)

8.1.3 SONET Link

A SONET Link is a fiber optic connection between a Telephone Company wire center and a customer premise. The SONET Link consists of two optical fibers connecting the customer premise and the Telephone Company wire center. The customer premise end of a SONET Link will be connected to a SONET Node at the customer premise. The central office end of a SONET Link may be connected to a SONET Node at the central office, or may be connected to one end of SONET Interoffice Mileage for the purpose of connecting to a SONET node at a different central office.

SONET Links are billed on a distance sensitive basis. The SONET Link rate is applied on the basis of the number of airline quarter miles from the customer premise to the central office. If the customer desires a four fiber connection to the SONET node at the customer premise (e.g., 1+1 protection), a second SONET Link may be ordered. If the customer requests diverse routing for the second SONET Link, special construction charges as specified in the applicable Interstate Special Construction Tariff will apply. The Telephone Company will comply with the request for diverse routing if it is technically feasible and the customer agrees to the cost of the special construction. If the diverse SONET Link is provided from an alternate wire center, the airline miles for the diverse link will be measured from the alternate wire center to the customer premise. In addition, SONET interoffice mileage will be needed even if it would not be needed absent the route diversity.

8.1.4 SONET Interoffice Mileage

SONET Interoffice Mileage provides a data transmission path between two Telephone Company central offices. The data transmission path provided will support the transmission speed of the selected SONET service, but is not guaranteed to be provided over fiber dedicated to a specific customer.

The end of a segment of SONET Interoffice Mileage may be connected to a SONET Node located in the appropriate central office, or to a SONET Link for connection to a SONET Node at a customer premise.

The SONET Interoffice mileage rate element consists of a fixed and mileage sensitive portion. The fixed portion of the rate element is billed per segment of SONET Interoffice Mileage. The mileage sensitive portion is billed per mile, based on the airline distance between the two wire centers involved.

ACCESS SERVICE

8. Advanced Communications Services (Cont'd)

8.1 SONET Special Access Service (Cont'd)

8.1.5 SONET Port

A SONET Port is an industry standard interface of the designated type and capacity. SONET Ports are provided at SONET Nodes, and provide the capacity to connect all or a portion of the SONET service to customer owned equipment or other Telephone Company provided services. SONET Ports represent mapping of the designated amount and type of capacity within the SONET service. Because this mapping must define a complete path through the SONET service, each SONET Port must be associated with another SONET Port of the same type on a different node of the SONET service. This has the practical effect of requiring SONET Ports to be ordered in pairs.

A SONET Port may be connected to another service of the same type, e.g. a DS1 SONET Port may be connected to a DS1 service or a DS3 SONET Port may be connected to a DS3 service. A SONET Port may be connected to a SONET Port of the same type on a different SONET service. For example, and OC-3c SONET Port on an OC-12 SONET node may be connected to an OC-3c SONET Port on an OC-3 SONET Node in the same central office. A SONET Port may not be connected to another SONET Port on the same SONET Node. When the SONET Node is at the customer location, a SONET Port may be connected to customer owned equipment.

SONET Ports do not include redundant protection from equipment failure. A customer wishing to have redundant protection from equipment failure at the port level may order a second pair of SONET Ports to protect the primary service. The protect ports will be provisioned at the same SONET Nodes as the primary ports.

8.1.6 SONET Reconfiguration Charge

The SONET Reconfiguration Charge is a non-recurring charge that is applied when the customer requests changes to an existing SONET service. The changes requested may include installation of additional ports; removal of existing ports; reconfiguration of an existing port to be located at a different node; or any combination of the above. One SONET Reconfiguration charge will apply per change request regardless of how many new, discontinued, and reconfigured ports are requested. The SONET Reconfiguration Charge does not apply to the initial order for a SONET service.

ACCESS SERVICE

8. Advanced Communications Services (Cont'd)

8.1 SONET Special Access Service (Cont'd)

8.1.7 Rate Regulations

SONET service is offered only under term commitment periods, or term plans. The applicable commitment periods are 12 months, 24 months, 36 months, or 60 months. If the customer discontinues service prior to the expiration of the chosen period, the regulations in Section 7.4.8 of this Guide will apply.

Additional charges may be billed to the customer when the Company is levied charges for space and power required to place multiplexers on the Company's side of the network interface.

The customer is responsible for identifying what service configuration is to be provided when the SONET service is initially installed. This information is to be provided on the service order.

The removal or addition of a SONET Node will be considered the termination of one SONET Service and installation of a different SONET Service. Appropriate termination charges will apply in this case.

Monthly recurring charges apply for SONET Nodes, SONET Links, SONET Interoffice Mileage, and SONET Ports. A nonrecurring SONET Reconfiguration Charge applies when SONET Ports are added to, removed from, or reconfigured within an existing SONET service. A Maintenance of Service Charge will apply if the customer reports trouble, the Telephone Company dispatches a technician, and no trouble is found in the Telephone Company's service or equipment. Additional charges may apply if extraordinary costs are incurred to provision SONET service. These charges will be determined as specified in Section 12 of this Guide.

SONET service is available with transmission capacity defined by Optical Carrier (OC) Rates. The Optical Carrier Rates are in multiples of an OC-1, which is equivalent to an STS1 (synchronous transport signal) (54.84 Mbps), SONET's basic rate. The OC Rates offered by the Telephone Company are:

<u>OC Rate</u>	<u>Bandwidth Capacity</u>
OC-3	155.520 Mbps
OC-12	622.080 Mbps
OC-48	2.488 Gbps

Rates for SONET service are set forth in Section 16 following.

ACCESS SERVICE

9. Grandfathered Service

9.1 General

Grandfathered services are offerings which are limited to existing customers and are not available to new customers. The services listed in this section are shown to be grandfathered or limited to existing service provided to existing customers. Existing service is service that was in place prior to the service being grandfathered. Existing customers are those customers who were already subscribing to a service prior to the service being grandfathered.

New customers are not eligible to subscribe to a grandfathered service. This includes previously grandfathered customers who have for any reason discontinued their grandfathered service.

ACCESS SERVICE

10. RESERVED FOR FUTURE USE

ACCESS SERVICE

11. Special Facilities Routing of Access Services

11.1 Description of Special Facilities Routing of Access Services

The services provided under this Guide are provided over such routes and facilities as the Telephone Company may elect. Special Facilities Routing is involved, when, in order to comply with requirements specified by the customer, the Telephone Company provides Switched Access Service, Special Access Service or Special Federal Government Access Service in a manner which includes one or more of the following conditions:

11.1.1 Diversity

Two or more services must be provided over not more than two different physical routes.

11.1.2 Avoidance

A service must be provided on a route which avoids specified geographical locations.

11.1.3 Cable-Only Facilities

Certain Voice Grade services are provided on Cable-Only Facilities to meet the particular needs of a customer.

Service is provided subject to the availability of Cable-Only facilities. In the event of service failure, restoration will be made through the use of any available facilities as selected by the Telephone Company.

Avoidance and Diversity are available on Voice Grade and Special Access Services as set forth in 7.2.3 preceding. Cable-Only Facilities are available for Voice Grade Special Access Services as set forth in 7.2.3 preceding.

ACCESS SERVICE

11. Special Facilities Routing of Access Services (Cont'd)

11.1 Description of Special Facilities Routing of Access Services (Cont'd)

11.1.3 Cable-Only Facilities (Cont'd)

In order to avoid the compromise of special routing information, the Telephone Company will only provide the required routing information for each specifically routed service to the ordering customer. If requested by the customer, this information will be provided when service is installed and prior to any subsequent changes in routing.

The rates and charges for Special Facilities Routing of Access Services as set forth in 11.2 following are in addition to all other rates and charges that may be applicable for services provided under other sections of this Guide.

11.2 Rates and Charges for Special Facilities Routing of Access Services

The rates and charges for Special Facilities Routing of Access Services are as follows:

11.2.1 Diversity

For each service provided in accordance with 11.1.1 preceding, the rates and charges will be developed on an Individual Case Basis.

11.2.2 Avoidance

For each service provided in accordance with 11.1.2 preceding, the rates and charges will be developed on an Individual Case Basis.

11.2.3 Diversity and Avoidance Combined

For each service provided in accordance with 11.1.1 and 11.1.2 preceding, combined, the rates and charges will be developed on an Individual Case Basis.

11.2.4 Cable-Only Facilities

For each service provided in accordance with 11.1.3 preceding, the rates and charges will be developed on an Individual Case Basis.

ACCESS SERVICE

12. RESERVED FOR FUTURE USE

ACCESS SERVICE

13. Additional Engineering, Additional Labor and Miscellaneous Services

In this section normally scheduled working hours are an employee's scheduled work period in any given calendar day (e.g., 7:00 a.m. to 4:00 p.m.) for the application of rates based on working hours.

13.1 Additional Engineering

Additional Engineering will be provided by the Telephone Company at the request of customer only when:

(A) A customer requests additional technical information after the Telephone Company has already provided the technical information normally included on the Design Layout Report (DLR) as set forth in 6.1.5 and 7.1.6 preceding.

(B) Additional engineering time is incurred by the Telephone Company to engineer a customer's request for a customized service as set forth in 7.2 preceding.

(C) A customer requests a design change which requires additional engineering review as set forth in 5.2.2(C). The charge for Additional Engineering will apply whether or not the customer authorizes the Telephone Company to proceed with the design change.

The Telephone Company will notify the customer that additional engineering charges, as set forth in Section 16 following will apply before any additional engineering is undertaken.

13.2 Additional Labor

Additional Labor is that labor requested by the customer on a given service as set forth in 13.2.1 through 13.2.5 following. The Telephone Company will notify the customer that additional labor charges as set forth in Section 16 following will apply before any additional labor is undertaken. Charges for additional labor will apply per order submitted.

13.2.1 Overtime Installation

Overtime Installation is that Telephone Company installation effort outside of normally scheduled working hours.

13.2.2 Overtime Repair

Overtime Repair is that Telephone Company maintenance effort performed outside of normally scheduled working hours.

ACCESS SERVICE

13. Additional Engineering, Additional Labor and Miscellaneous Services (Cont'd)

13.2 Additional Labor (Cont'd)

13.2.3 Stand By

Stand by includes all time in excess of one-half (1/2) hour during which Telephone Company personnel stand by to make installation acceptance tests or cooperative tests with a customer to verify facility repair on a given service.

13.2.4 Testing and Maintenance with Other Telephone Companies

Additional testing, maintenance or repair of facilities which connect to facilities of other telephone companies which is in addition to normal effort required to test, maintain or repair facilities provided solely by the Telephone Company.

13.2.5 Other Labor

Other labor is that additional labor not included in 13.2.1 through 13.2.4 preceding, including, but not limited to labor incurred for the installation of inside wire, used to extend the Point of Termination as set forth in 2.1.5 preceding, and labor incurred to accommodate a specific customer request that involves only labor which is not covered by any other section of this Guide.

13.3 Miscellaneous Services

13.3.1 Maintenance of Service

(A) When a customer reports a trouble to the Telephone Company for clearance, the customer shall be responsible for payment of a Maintenance of Service charge when Telephone Company personnel test the service and no trouble is found in the Telephone Company's facilities. Failure of Telephone Company personnel to find trouble in Telephone Company facilities will result in no charge if the trouble is actually in those facilities, but not discovered at the time.

(B) The customer shall be responsible for payment of a Maintenance of Service charge when the Telephone Company dispatches personnel to the customer's designated premises, and the trouble is in equipment or communications systems provided by other than the Telephone Company or in detariffed CPE provided by the Telephone Company.

In either (A) or (B) preceding, no credit allowance will be applicable for the interruption involved if the Maintenance of Service Charge applies.

The charges for Maintenance of Service are set forth in Section 16, following.

ACCESS SERVICE

13. Additional Engineering, Additional Labor and Miscellaneous Services (Cont'd)

13.3 Miscellaneous Services (Cont'd)

13.3.2 Emergency Services

(A) Restoration Priority

The Telephone Company will arrange a Special Access Service for Restoration Priority on receipt of certification in conformance with Part 64, Subpart D, Appendix A of the Federal Communication Commission's Rules and Regulations. A charge applies when a request to provide or change a Restoration Priority is received subsequent to the issuance of an Access Order to install the service. No charge applies when a Restoration Priority is discontinued. Rates for Restoration Priority are set forth in Section 16, following.

(B) Telecommunications Service Priority (TSP)

(1) Customers can request assignment to the TSP system through the following agencies:

<u>Customer</u>	<u>Referral</u>
Federal Agencies	TSP Program Office
State and Local Governments	Federal Emergency Management Agency
Foreign Governments	Departments of State or Defense
Private Industry	Any Federal Agency but normally one with whom they have a contractual relationship involving an NSEP function

The TSP Program Office is contained within the National Communications System.

(2) Once customers have received their TSP assignment, signified by a TSP Authorization Code, from the proper authorities, the customer must submit the code along with a service request to the Company.

The TSP Authorization Code contains two parts: the TSP Control ID, a number generated for tracking purposes and the TSP code. The TSP code had the following two elements:

- The Provisioning priority : E,1,2,3,4,5 or 0
- The restoration priority : 1,2,3,4,5, or 0

ACCESS SERVICE

13. Additional Engineering, Additional Labor and Miscellaneous Services (Cont'd)

13.3 Miscellaneous Services (Cont'd)

13.3.2 Emergency Services (Cont'd)

(B) Telecommunications Service Priority (TSP) (Cont'd)

(3) The Company will send a Service Confirmation to the TSP Program Office upon the completion of an ordered TSP service within 45 calendar days of the completion.

The Company may verify provisioning priority assignments with the TSP Program Office. However, the Company may not delay provisioning of an Emergency TSP service for verification purposes.

In obtaining TSP, the customer authorizes the Company to provide certain customer record information to the TSP Program Office so that that Office can maintain and administer the TSP System. This customer record information will include only the customer's name, TSP authorization code, Telephone Company circuit ID, customer telephone number and customer mailing address.

(4) The Company will provision and restore, when necessary, those telecommunication services with TSP assignments before services without such assignments.

When spare facilities are not available, it may be necessary for the Company to preempt the facilities required to provision or restore TSP service. When such preemption is necessary, the Company will make a reasonable effort to notify the preempted customer of the action to be taken prior to preemption. Credit allowances for such service preemption shall be made according to the provisions set forth in 2.4.4 (E) preceding. When preemption is necessary, the sequence in which existing services may be preempted is as follows:

Non-TSP services

TSP services selected in inverse order of their priority level assignment

ACCESS SERVICE

13. Additional Engineering, Additional Labor and Miscellaneous Services (Cont'd)

13.3 Miscellaneous Services (Cont'd)

13.3.2 Emergency Services (Cont'd)

(B) Telecommunications Service Priority (TSP) (Cont'd)

(5) A TSP service priority does not imply any actual lead time or a specific interval for either provisioning or restoration.

The Company is not authorized or required to provide priority treatment to provision TSP services to customers that have no provisioning priority (i.e., "0" is the first character of the TSP code).

(6) When the Company cannot meet an Essential TSP customer's request for receiving service within normal operating procedures, the Company will attempt to provide an alternative due date that is acceptable to the customer. If an agreement cannot be reached, the customer can invoke NSEP treatment and obtain provisioning priority assignment from the TSP Program Office if this service meets specific TSP Program Office guidelines. All order processing charges, including expedited order charge if applicable, will apply as set forth in Section 5.2, preceding.

(7) In the event that the Company must utilize specially constructed facilities in the priority installation of an access service, the regulations, rates and charges set forth in the applicable Interstate Special Construction Tariff for the service for which priority installation is required shall also apply. The Company will endeavor to notify the customer of such charges in advance. The customer, in invoking an installation priority, recognizes, however, that quoting charges and obtaining customer permission to proceed with service installation may unduly delay the installation, in contradiction to the underlying rules and regulations of TSP. In subscribing to TSP, the customer recognizes this condition and grants the Company the right to assess special construction charges after the installation has been completed.

(8) The Company will designate a 24-hour point of contact for receiving Emergency TSP provision requests and reports that a TSP service is out of service.

ACCESS SERVICE

13. Additional Engineering, Additional Labor and Miscellaneous Services (Cont'd)

13.3 Miscellaneous Services (Cont'd)

13.3.2 Emergency Services (Cont'd)

(B) Telecommunications Service Priority (TSP) (Cont'd)

(9) Control services or underwires wholly owned and supplied by the Company and needed for provisioning, restoration, or maintenance are exempt from TSP rules.

(10) In the event that the Company must utilize additional labor in the restoration of an access service, additional labor charges as outlined in Section 13.2, preceding, may apply. The Company will endeavor to notify the customer of such charges in advance. The customer, in invoking a restoration priority, recognizes, however, that quoting charges and obtaining customer permission to proceed with service restoration may unduly delay the restoration process, in contradiction to the underlying rules and regulations of TSP. In subscribing to TSP, the customer recognizes this condition and grants the Company the right to assess such additional labor charges as may be applicable after the restoration has been completed.

(11) Rates and Charges

TSP assignment charge is on a per circuit or access line basis. Customers wishing to establish TSP for auxiliary numbers or circuits associated with a main billing or calling number must purchase TSP for each line assigned.

The TSP Record Order Change Charge applies to all record modifications per TSP designated line or circuit.

Rates and charges for TSP are set forth in Section 16, following.

ACCESS SERVICE

13. Additional Engineering, Additional Labor and Miscellaneous Services (Cont'd)

13.3 Miscellaneous Services (Cont'd)

13.3.3 Reserved

13.3.4 Reserved

ACCESS SERVICE

13. Additional Engineering, Additional Labor and Miscellaneous Services (Cont'd)

13.3 Miscellaneous Services (Cont'd)

13.3.4 Billing Name and Address Service (Cont'd)

(A) Undertaking Of The Telephone Company

(1) Upon receipt of a magnetic tape of end user telephone numbers, the Telephone Company will, at the request of the customer, provide BNA Service on a mechanized basis. The Telephone Company will enter the BNA information on the telephone numbers tape and send the tape to the customer by first class U.S. Mail. Other methods of delivering the data may be negotiated, and charges based on cost will apply.

The Telephone Company will provide a response to customer-provided tapes by mail within ten (10) business days of receipt.

(2) The Telephone Company will specify the format in which requests and tapes are to be submitted.

(3) The BNA information will be provided for listed and published billing numbers to the extent a billing name and address exists in the Telephone Company database.

(4) The Telephone Company will provide the most current BNA information resident in its database. Due to normal end user account activity, there may be instances where the BNA information provided is not the BNA that was applicable at the time the message was originated.

(B) Obligations of the Customer

(1) With each order for BNA Service, the customer shall identify the authorized individual and address to receive the BNA information.

(2) A customer which orders BNA Service on a mechanized basis must do so in the format specified by the Telephone Company.

ACCESS SERVICE

13. Additional Engineering, Additional Labor and Miscellaneous Services (Cont'd)

13.3 Miscellaneous Services (Cont'd)

13.3.4 Billing Name and Address Service (Cont'd)

(B) Obligations of the Customer(Cont'd)

(3) The customer shall institute adequate internal procedures to insure that BNA information is used only for the purpose set forth in this Guide and that BNA information is available only to those customer personnel or agents with a need to know the information. The customer must handle all billing name and address information designated as confidential by the Telephone Company in accordance with Telephone Company's procedures concerning confidential information.

(4) The customer shall not publicize or represent to others that the Telephone Company jointly participates with the customer in the development of the customer's end user records, accounts, data bases or market data, records, files and data bases or other systems it assembles through the use of BNA Service.

(5) The Telephone Company shall use reasonable efforts to provide accurate and complete lists. The Telephone Company makes no warranties, expressed or implied, as to the accuracy or completeness of these lists.

(C) Rate Regulations

(1) Service Establishment Charges apply for the initial establishment of BNA Service on a manual or mechanized basis.

(2) A charge applies for each BNA request on a manual or mechanized basis. This charge will apply for each number searched whether or not the Telephone Company is able to provide BNA information.

(3) When a customer cancels an order for BNA Service after the order date, the Service Establishment Charge applies.

(D) Rates and Charges

Rates and charges for Billing Name and Address Service are set forth in Section 16, following.

ACCESS SERVICE

- 13. Additional Engineering, Additional Labor and Miscellaneous Services (Cont'd)
 - 13.3 Miscellaneous Services (Cont'd)
 - 13.3.5 Reserved
-

ACCESS SERVICE

- 13. Additional Engineering, Additional Labor and Miscellaneous Services (Cont'd)
 - 13.3 Miscellaneous Services (Cont'd)
 - 13.3.6 Testing Services (Cont'd)
-

ACCESS SERVICE

- 13. Additional Engineering, Additional Labor and Miscellaneous Services (Cont'd)
 - 13.3 Miscellaneous Services (Cont'd)
 - 13.3.6 Testing Services (Cont'd)
-

ACCESS SERVICE

- 13. Additional Engineering, Additional Labor and Miscellaneous Services (Cont'd)
 - 13.3 Miscellaneous Services (Cont'd)
 - 13.3.6 Testing Services (Cont'd)
-

ACCESS SERVICE

- 13. Additional Engineering, Additional Labor and Miscellaneous Services (Cont'd)
- 13.3 Miscellaneous Services (Cont'd)
- 13.3.6 Testing Services (Cont'd)

ACCESS SERVICE

13. Additional Engineering, Additional Labor and Miscellaneous Services (Cont'd)

13.3 Miscellaneous Services (Cont'd)

13.3.6 Testing Services (Cont'd)

(B) Special Access Service

The Telephone Company will, at the request of a customer, provide assistance in performing specific tests requested by the customer.

(1) Additional Cooperative Acceptance Testing (ACAT)

When a customer provides a technician at its premises or at an end user's premises, with suitable test equipment to perform the requested tests, the Telephone Company will provide a technician at its office for the purpose of conducting Additional Cooperative Acceptance Testing on Voice Grade Services. At the customer's request, the Telephone Company will provide a technician at the customer's premises or at the end user premises. These tests may, e.g., consist of the following:

- VG1 through VG5: Attenuation Distortion, and Echo Control.
- VG6 through VG12: Attenuation Distortion, Echo Control, Phase Jitter, Intermodulation Distortion, Envelope Delay Distortion and Frequency Shift.

(2) Additional Manual Testing (AMT)

The Telephone Company will provide a technician at its premises, and the Telephone Company or customer will provide a technician at the customer's designated premises with suitable test equipment to perform the requested tests.

(3) Obligation of the Customer

When the customer subscribes to Testing Service as set forth in this section, the customer shall make the facilities to be tested available to the Telephone Company at times mutually agreed upon.

ACCESS SERVICE

13. Additional Engineering, Additional Labor and Miscellaneous Services (Cont'd)
- 13.3 Miscellaneous Services (Cont'd)
- 13.3.7 Provision of Access Service Billing Information
- (A) The customer will receive its monthly bills in either a standard paper or magnetic tape format.
- (B) At the option of the customer, and for an additional charge:
- (1) Customer monthly bills may be provided on both magnetic tape and paper format.
- (2) Billing detail and/or information may be transmitted to the customer premises by data transmission.
- (3) Additional copies of the customer monthly bill may be provided in standard paper format.
- (C) Upon acceptance by the Telephone Company of an order for data transmission, the Telephone Company will determine the period of time to implement the transmission of such material on an individual order basis.
- (D) The rates and charges for the provision of Access Service Billing Information are set forth in Section 16 following.

ACCESS SERVICE

14. Exceptions to Access Service Offerings

The services offered under the provisions of this Guide are subject to availability as set forth in Section 2.1.4 preceding.

ACCESS SERVICE

15. Contract Services

15.1 Reserved

15.2 Reserved

15.3 Reserved

15.4 Reserved

15.5 Contract Services

This section contains terms and conditions and rates and charges for contract tariffs provided by the Telephone Company.

Contract tariffs are subject to the regulations specified in all other applicable sections of this Guide, unless otherwise specified.

ACCESS SERVICE

15. Metropolitan Statistical Area Services (Cont'd)

15.5 Contract Services (Cont'd)

15.5.1 Contract Tariff Option 1

Contract Tariff Option 1 is offered for a period of two years and provides a customer with annual credits when it meets certain billed revenue growth thresholds set forth in this section. The two year period begins with the first bills rendered after the effective date of the contract, which must be within 30 days of the effective date of this tariff.

Contract Tariff Option 1 is available in the portion of the Rochester, NY MSA that is served by Frontier Telephone of Rochester. Covered services are special access, and advanced services as described in Sections 7 and 8 of this tariff. The credits provided under Contract Tariff Option 1 are based on the growth in Monthly Recurring Charge (MRC) revenue billed to the customer.

A customer may subscribe to Contract Tariff Option 1 by submitting a written authorization in a manner designated by the Telephone Company in the 30 day period which begins on January 31, 2009 and ends on March 2, 2009.

(A) Volume and Growth Measurement

The volume and growth governed by Contract Tariff Option 1 are measured in Billed MRC Revenue, defined as revenue billed by the Telephone Company to the Customer for Monthly Recurring Charges for the covered services. Nonrecurring charges, surcharges, and other charges and credits will not be used to compute Billed MRC Revenue.

The customer commits to maintain Billed MRC Revenue of at least \$8,000,000 (\$8M) per year for the covered services.

The customer commits to grow Billed MRC Revenue for the covered services by at least four percent (4%) in each of the two years covered by the contract. The penalty for failing to meet the volume or growth commitments is loss of part or all of the credits available under Contract Tariff Option 1.

(B) Rates

The Monthly Recurring Charge rates paid by the customer for covered services will be the applicable tariffed rates for each covered service.

ACCESS SERVICE

15. Metropolitan Statistical Area Services (Cont'd)

15.5 Contract Services (Cont'd)

15.5.1 Contract Tariff Option 1 (Cont'd)

(C) Measurement of Growth and Credits

Growth of Billed MRC Revenue is measured against a Baseline Annualized Spend for each of the two years covered by the contract.

The Initial Baseline Annualized Spend (IBAS) is the Billed MRC Revenue for the month immediately preceding the start of the contract period, multiplied by 12.

Year 1 Annualized Spend (Y1AS) is the Billed MRC Revenue for the 12th month of the contract period, multiplied by 12.

Year 2 Baseline Annualized Spend (Y2BAS) is the greater of the Initial Baseline Annualized Spend or Year 1 Annualized Spend.

Year 2 Annualized Spend (Y2AS) is the Billed MRC Revenue for the 24th month of the contract period, multiplied by 12.

Year 1 growth is computed by comparing Year 1 Annualized Spend to the Initial Baseline Annualized Spend. Year 2 growth is computed by comparing Year 2 Annualized Spend to Year 2 Baseline Annualized Spend.

The Discount Factor is 30%.

Year 1 Growth Credit (Y1GC) is calculated as follows:

If $Y1AS < IBAS * 1.04$, $Y1GC = 0$. Otherwise,
 $Y1GC = (Y1AS - (IBAS * 1.03)) * \text{Discount Factor}$

Year 2 Growth Credit (Y2GC) is calculated as follows:

If $Y2AS < Y2BAS * 1.04$, $Y2GC = 0$. Otherwise,
 $Y2GC = (Y2AS - (Y2BAS * 1.03)) * \text{Discount Factor}$

Year 2 Carryover Credit (Y2CC) is calculated as follows:

If $Y2AS > Y1AS$, $Y2CC = Y1GC$
 If $Y2AS < IBAS * 1.04$, $Y2CC = 0$. Otherwise,
 $Y2CC = (Y2AS - (IBAS * 1.03)) * \text{Discount Factor}$

ACCESS SERVICE

15. Metropolitan Statistical Area Services (Cont'd)

15.5 Contract Services (Cont'd)

15.5.1 Contract Tariff Option 1 (Cont'd)

(D) Application of Credits

Credits earned under Contract Tariff Option 1 will be applied to the customer's bills every six months and trued up annually. Credits will be applied 90 days following the bill date of the 6th, 12th, 18th, and 24th months of the agreement.

The credits applied after the 6th month of the contract will be based on comparing the 4th, 5th, and 6th months of the contract to the same period from the preceding year. The credits applied after the 18th month of the contract will be based on comparing the 16th, 17th, and 18th months of the contract to the 4th, 5th, and 6th months of the contract. These comparisons will be used to compute estimated growth rates and credits. One half of the estimated credits computed on an annualized basis will be applied in this way. The true annual credits will be trued up following the 12th and 24th months of the contract.

The application of credits earned under this Contract Tariff Option 1 is contingent on payment in full by the customer of all undisputed billed amounts for covered services no later than 60 days from the bill date of the last bill used to compute an Annualized Spend. After 60 days, any amounts that remain disputed or are withheld by the customer shall be excluded from the calculation of the Year 1 Annualized Spend or Year 2 Annualized Spend, as appropriate to the date(s) the disputed amounts were billed.

ACCESS SERVICE

15. Metropolitan Statistical Area Services (Cont'd)

15.5 Contract Services (Cont'd)

15.5.1 Contract Tariff Option 1 (Cont'd)

(E) Mergers and Acquisitions

In the event the customer merges with another company, acquires a company or a portion of the business of another company, or is acquired in whole or in part by another company, the following terms and conditions will apply in addition to any other terms and conditions set forth in this Contract Tariff Option.

The customer may not combine or include any revenues from the merged, acquiring, or acquired company, or assets of such merged, acquiring, or acquired company in the calculation of Billed MRC Revenue for the covered services.

The customer shall continue subscribing to Contract Tariff Option 1 for the duration of the contract period based on its business with the Telephone Company as of the start of the contract period, without adding any revenues attributable to the expansion of the customer's purchase of services from the Telephone Company through merger, transfer, assignment, or acquisition.

If the customer commingles its legacy business with merged, acquiring, or acquired business in such a manner that the Telephone Company cannot distinguish between the two types of business, there will be no credits due the customer after the date of the first such commingling.

ACCESS SERVICE

15. Metropolitan Statistical Area Services (Cont'd)

15.5 Contract Services (Cont'd)

15.5.2 Contract Tariff Option 2

(A) Scope

Contract Tariff Option 2 (**Option 2**) provides Quarterly Billing Credits or Adjustments on certain Special Access Services if the customer maintains an Annual Spend Premium of specified amounts. In this Option 2, all references to amounts represented in dollars followed by the letter "M" shall refer to such number in millions (e.g., \$17.25M shall mean \$17,250,000).

(B) Specific Terms

Unless otherwise defined in this Option 2, the following terms are used in this Option 2.

- (1) **Annual Spend Premium** shall mean the amount the customer spends in each year for Qualifying Services above the average rates in effect in July 2012. The Annual Spend Premium shall be calculated as the difference between the Total Flat Rate Spend less the Total Baseline Reference Spend on an annual basis.
- (2) **BANs** shall mean the Billing Account Numbers of the customer.
- (3) **Baseline Reference Spends** shall mean the amounts the customer would have spent for DS1, Multiplexed DS3, or PTP DS3 service at the customer's Baseline Unit Reference Costs for these services. The Baseline Reference Spends shall be calculated as follows:

Baseline Reference DS1 Spend = DS1 Billed Units * DS1 Baseline Unit Reference Cost

Baseline Reference Multiplexed DS3 Spend
= Multiplexed DS3 Billed Units * Multiplexed DS3 Unit Reference Cost

Baseline Reference PTP DS3 Spend
= PTP DS3 Billed Units * PTP DS3 Unit Reference Cost

Total Baseline Reference Spend
= Baseline Reference DS1 Spend
+ Baseline Reference Multiplexed DS3 Spend
+ Baseline Reference PTP DS3 Spend

ACCESS SERVICE

15. Metropolitan Statistical Area Services (Cont'd)

15.5 Contract Services (Cont'd)

15.5.2 Contract Tariff Option 2 (Cont'd)

(B) Specific Terms (Cont'd)

- (4) **Baseline Unit Reference Costs** shall mean the unit cost per circuit for the customer's Billed DS1 Units, Billed Multiplexed DS3 Units, and Billed PTP DS3 Units calculated as of July 2012 billing to the customer, net of any credits earned under tariff arrangements or contract tariffs in effect during July 2012.
- (5) **Billed DS1 Unit** shall mean, with respect to each month during the Service Period, a DS1 Unit for which one or more monthly recurring charge was billed using any of the applicable Universal Service Order Codes (**USOCs**) set forth in (F)(2)(a) following, to the customer under the Customer ACNAs (as defined in (B)(11) following) in the monthly recurring charge (**MRC**) section of Telephone Company's Access Service bill to the customer for that month. For the avoidance of any doubt, a DS1 circuit that is provided in a meet point arrangement by two or more Telephone Company entities under a single unique circuit identifier will count as two units. Additionally, a DS1 circuit that is provided in a meet point arrangement by two or more billing entities under a single unique circuit identifier, where only one of the billing entities is affiliated with the Telephone Company, will count as one unit.
- (6) **Billed Multiplexed DS3 Unit** shall mean, with respect to each month during the Service Period, a Multiplexed DS3 Unit for which one or more MRCs, using any of the applicable USOCs set forth in (F)(2)(b) following, was billed to the customer under the Customer ACNAs (as defined in (B)(11) following) in the MRC section of Telephone Company's Access Service bill to the customer for that month. For the avoidance of any doubt, a Multiplexed DS3 circuit that is provided in a meet point arrangement by two or more Telephone Company entities under a single unique circuit identifier will count as two units. Additionally, a Multiplexed DS3 circuit that is provided in a meet point arrangement by two or more billing entities under a single unique circuit identifier, where only one of the billing entities is affiliated with the Telephone Company, will count as one unit.

ACCESS SERVICE

15. Metropolitan Statistical Area Services (Cont'd)

15.5 Contract Services (Cont'd)

15.5.2 Contract Tariff Option 2 (Cont'd)

(B) Specific Terms (Cont'd)

- (7) **Billed PTP DS3 Unit** shall mean, with respect to each month during the Service Period, a point-to-point (PTP) DS3 Unit for which one or more MRCs, using any of the applicable USOCs set forth in (F)(2)(c) following, was billed to the customer under the Customer ACNAs (as defined in (B)(11) following) in the MRC section of Telephone Company's Access Service bill to the customer for that month. For the avoidance of any doubt, a PTP DS3 circuit that is provided in a meet point arrangement by two or more Telephone Company entities under a single unique circuit identifier will count as two units. Additionally, a PTP DS3 circuit that is provided in a meet point arrangement by two or more billing entities under a single unique circuit identifier, where only one of the billing entities is affiliated with the Telephone Company, will count as one unit.
- (8) **Billed Qualifying Service Revenue** shall mean each of Billed DS1 Qualifying Service Revenue, Billed Multiplexed DS3 Qualifying Service Revenue, and Billed PTP DS3 Qualifying Service Revenue as further described in (F) following, subject to the exclusions specified in (F)(2)(d) and (F)(3) following.
- (9) **Billed Qualifying Service Unit(s)** shall mean Billed DS1 Units, Billed Multiplexed DS3 Units, and/or Billed PTP DS3 Units, subject to the exclusions set forth in (F)(2)(d) and (F)(3) following.
- (10) **Billed Spends** shall mean the amounts the customer is billed for Qualifying Services by the Telephone Company under the applicable tariffed rates, terms, and conditions. Billed DS1 Spend is the amount billed by the Telephone Company for DS1 Qualifying Services; Billed Multiplexed DS3 Spend is the amount billed by the Telephone Company for Multiplexed DS3 Qualifying Services; Billed PTP DS3 Spend is the amount billed by the Telephone Company for PTP DS3 Qualifying Services; and Total Billed Spend is the sum of Billed DS1 Spend, Billed Multiplexed DS3 Spend, and Billed PTP DS3 Spend.
- (11) **Customer ACNA(s)** shall mean the customer's Access Customer Name Abbreviations (ACNAs) that are provided to the Telephone Company by the customer in its subscription to this Option 2, Option 63 of FCC 4, and Option 32 of FCC 5 in accordance with (C)(2) following, which Customer ACNA(s) are agreed to by the Telephone Company in writing for inclusion in this Option 2, Option 63 of FCC 4, and Option 32 of FCC 5.

ACCESS SERVICE

15. Metropolitan Statistical Area Services (Cont'd)

15.5 Contract Services (Cont'd)

15.5.2 Contract Tariff Option 2 (Cont'd)

(B) Specific Terms (Cont'd)

- (12) **DS1 Unit** shall mean an individual Qualifying Service circuit of DS1 capacity (i.e., 1.544 Mbps) that that both: (i) has a unique facilities formatted circuit identifier in accordance with the Common Language Circuit Identifier (CLCI) format administered by Telcordia, and (ii) is billed using any of the applicable USOCs set forth in F(2)(b) below.

For the avoidance of any doubt, a DS1 circuit that is provided in a meet point arrangement by two or more Telephone Company entities under a single unique circuit identifier will count as two units . Additionally, a DS1 circuit that is provided in a meet point arrangement by two or more billing entities under a single unique circuit identifier, where only one of the billing entities is affiliated with the Telephone Company, will count as one unit. For the avoidance of any doubt, sub-rate DS1s (e.g., 128 kbps, 256 kbps, 384 kbps, 512 kbps, and 768 kbps) are not counted as DS1 Units.

- (13) **Flat Rate** shall mean the flat rate monthly recurring charge that applies per Billed Qualifying Service Unit, per service type (i.e., DS1, Multiplexed DS3, and PTP DS3), for a given Plan Year as calculated in accordance with (H)(1) following.

- (14) **Flat Rate Spend** shall mean the billed units for a given period multiplied by the Baseline Unit Reference Costs, by service type:

Flat Rate DS1 Spend = DS1 Billed Units * DS1 Flat Rate

Flat Rate Multiplexed DS3 Spend = Multiplexed DS3 Units * Multiplexed DS3 Flat Rate

Flat Rate PTP DS3 Spend = PTP DS3 Units * PTP DS3 Flat Rate

Total Flat Rate Spend = Flat Rate DS1 Spend
+ Flat Rate Multiplexed DS3 Spend + Flat Rate PTP DS3 Spend

- (15) **Groom(s)** shall mean a change in the connecting facility assignment (**CFA**) or termination point of a DS3 Service, and shall include any of the following types of moves, rearrangements, re-terminations, and disconnection and subsequent reconnection, to the DS3 Service: (i) a change in the CFA or termination point within a single Telephone Company wire center; (ii) a change in the CFA or termination point from one Telephone Company wire center to CFA in another Telephone Company wire center (CFA can be a facility provided by the Telephone Company or by a collocator.)

ACCESS SERVICE

15. Metropolitan Statistical Area Services (Cont'd)

15.5 Contract Services (Cont'd)

15.5.2 Contract Tariff Option 2 (Cont'd)

(B) Specific Terms (Cont'd)

- (16) **Multiplexed DS3 Unit** shall mean an individual Qualifying Service circuit of DS3 capacity (i.e., 44.736 Mbps) that both: (i) has a unique circuit identifier that conforms to the Common Language Circuit Identifier (CLCI) facility format administered by Telcordia and (ii) is billed using one or more of the USOCs specified in (F)(2)(b) following.

DSEF Service associated with a Multiplexed DS3 Unit (i.e. billed under the unique circuit identifier for that Multiplexed DS3 Unit) will not be counted as a unit separate from that Multiplexed DS3 Unit.

For purposes of administering the terms and conditions of this Option 2, all calculations involving Multiplexed DS3 Unit volumes shall exclude any portion of a circuit that is not used for Special Access. Where this calculation results in a fraction of a Multiplexed DS3 Unit, round to the nearest whole Multiplexed DS3 Unit. Thus, for example, if there were two (2) Shared Use Multiplexed DS3, and where one of the facilities is reduced by forty-five percent (45%) and the other facility is reduced by sixty-five percent (65%) in accordance with Section 5.2.7 preceding, then together they would count as only one (1) Multiplexed DS3 Unit (.45 + .65 = 1.10, rounded to the nearest integer, which in this case is one (1) Multiplexed DS3 Unit).

For purposes of administering the terms and conditions of this Option 2: (i) all DS1 FMS Services are converted to Multiplexed DS3 Units by dividing the total number of DS1 FMS Services by twenty-eight (28), and (ii) all DS3 FMS Services are quantified as either Multiplexed DS3 Units or PTP DS3 Units, depending on the format of the circuit identifier and the corresponding USOCs as described in the definitions of Multiplexed DS3 Unit and PTP DS3 Unit.

For the avoidance of any doubt, a Multiplexed DS3 circuit that is provided in a meet point arrangement by two or more Telephone Company entities under a single unique circuit identifier will count as two units. Additionally, a PTP DS3 circuit that is provided in a meet point arrangement by two or more billing entities under a single unique circuit identifier, where only one of the billing entities is affiliated with the Telephone Company, will count as one unit.

ACCESS SERVICE

15. Metropolitan Statistical Area Services (Cont'd)

15.5 Contract Services (Cont'd)

15.5.2 Contract Tariff Option 2 (Cont'd)

(B) Specific Terms (Cont'd)

(17) **Plan Year** shall mean each of the following periods during the Service Period: Plan Year 1 shall commence on the date on which the customer subscribes to this Option 2 and end on December 31, 2013; Plan Year 2 shall commence on January 1, 2014 and end on December 31, 2014; and Plan Year 3 shall commence on January 1, 2015 and end on December 31, 2015. In the event of any extension(s) of the Service Period pursuant to Section (E) following, "Plan Year" may also be used to refer to an applicable calendar year (i.e., January 1 through December 31) subsequent to Plan Year 3.

(18) **PTP DS3 Unit** shall mean an individual Qualifying Service circuit of DS3 capacity (i.e., 44.736 Mbps) that both: (i) has a unique circuit identifier that conforms to the CLCI serial number format administered by Telcordia and (ii) is billed using one or more of the USOCs specified in (F)(2)(c) following.

DSEF Service associated with a PTP DS3 Unit (i.e. billed under the unique circuit identifier for that PTP DS3 Unit) will not be counted as a unit separate from that PTP DS3 Unit.

For purposes of administering the terms and conditions of this Option 2, all DS3 FMS Services are quantified as either Multiplexed DS3 Units or PTP DS3 Units, depending on the format of the circuit identifier and the corresponding USOCs as described in the definitions of Multiplexed DS3 Unit and PTP DS3 Unit.

For the avoidance of any doubt, a PTP DS3 circuit that is provided in a meet point arrangement by two or more Telephone Company entities under a single unique circuit identifier will count as two units. Additionally, a PTP DS3 circuit that is provided in a meet point arrangement by two or more billing entities under a single unique circuit identifier, where only one of the billing entities is affiliated with the Telephone Company, will count as one unit.

(19) **Quarter** shall mean either of the following periods, as applicable: (i) the first Quarter of each Plan Year is the period beginning with the first date of the applicable Plan Year and ending on the last day of the second calendar month after the month in which the first date occurs (i.e., approximately ninety (90) calendar days thereafter), except for the initial Quarter of Plan Year 1, which shall commence on the date on which the customer subscribes to this Option 2, and shall end on March 31, 2013; or (ii) each consecutive three (3) month period thereafter commencing on the first day of the calendar month following the end of the prior Quarter and ending on the last day of the second calendar month after the month in which the first day appears.

ACCESS SERVICE

15. Metropolitan Statistical Area Services (Cont'd)

15.5 Contract Services (Cont'd)

15.5.2 Contract Tariff Option 2 (Cont'd)

(B) Specific Terms (Cont'd)

- (20) **Quarterly Flat Rate Billing Adjustment** shall mean the quarterly credit or debit that is calculated per service type (i.e., DS1, Multiplexed DS3, and PTP DS3) as described in (H) following.
- (21) **Quarterly Spend Premium** shall mean Total Flat Rate Spend less Total Baseline Reference Spend for the Quarter.
- (22) **Quarterly Spend Premium Target** shall mean the amount of Quarterly Spend Premium the customer has committed to. Quarterly Spend Premium Targets are set forth in (H) following.
- (22) **Quarterly Spend Premium Adjustment** shall mean the amount credited or debited to the customer to true up to the Quarterly Spend Premium Target. It is calculated as Quarterly Spend Premium Target less Quarterly Spend Premium.

(C) Eligibility

The customer must meet all of the following criteria in order to be eligible to receive the Quarterly Billing Credits as set forth in (I) following and other benefits of this Option 2.

- (1) During the twelve (12) month period ending on December 31, 2011, the customer must have achieved a minimum of \$250M in aggregate billed monthly recurring charges for all Qualifying Services purchased by the customer from the Telephone Company.
- (2) The customer must subscribe to Option 2 by submitting a written authorization in a manner designated by the Telephone Company during the period that begins January 5, 2013 and ends February 15, 2013. Such subscription must include a list of Customer ACNA(s) as defined in (B)(11) preceding.
- (3) The customer must concurrently subscribe to Option 63 of FCC 4, this Option 2, and Option 32 of FCC 5.
- (4) As of January 1, 2013, the customer must be concurrently subscribed, and must remain concurrently subscribed during the Service Period, to the Commitment Discount Plan (as set forth in Section 25.1 of FCC 4- and the Eight-and Ten-Year DS1 Term and Volume Plan (ETTVP) as set forth in Section 5.6.14 of FCC 5), (collectively, **Existing Plans**).
- (5) As of January 1, 2013, the customer may not be subscribed to the National Discount Plan ("NDP") as set forth in FCC 4, FCC 5, and FCC 6.

ACCESS SERVICE

15. Metropolitan Statistical Area Services (Cont'd)

15.5 Contract Services (Cont'd)

15.5.2 Contract Tariff Option 2 (Cont'd)

(D) Terms and Conditions

- (1) If the customer is currently subscribed to a contract tariff option that provides a discount, credit, or other reduction in rates or terms based on achievement of revenue or volume targets/levels by the customer, the customer's subscription to such contract tariff option shall be cancelled coincident with the customer's subscription to this Option 2, Option 63 of FCC 4, and Option 32 of FCC 5, and the Telephone Company will conduct a final true-up of any billing credits the customer was entitled to through the date of cancellation.
- (2) Except for the Existing Plans and any FMS Services to which the customer subscribes to as of January 1, 2013, the customer may not concurrently subscribe the Qualifying Services to any other tariff arrangement, contract tariff option, specialized service arrangement, or Individual Case Basis (**ICB**) arrangement offered by the Telephone Company under this tariff, FCC 4, or FCC 5 and available to the customer either currently or at any time during the Service Period, which tariff arrangement, contract tariff option, specialized service or arrangement, or ICB provides a discount, credit, or other reduction in rates or terms based on achievement of revenue or volume targets/levels by the customer for any of the Qualifying Services during the Service Period. Except as set forth in this (D)(2) and (D)(1) preceding, the customer's subscription to any such Alternate Tariff Arrangement as of January 1, 2013 shall be terminated upon subscription to this Option 2, Option 63 of FCC 4, and Option 32 of FCC 5. The Telephone Company shall perform any final review/true-up that it determines to be necessary to reconcile any credits and debits that remain outstanding under such Alternate Tariff Arrangement.
- (3) To the extent the customer, as of January 1, 2013 or at any time during the Service Period, is not subscribed to the Existing Plans (i.e., with respect to the applicable Qualifying Services that the Telephone Company offers under the respective Existing Plans), the applicable Qualifying Services shall not be eligible to receive the Flat Rate pricing set forth in (H) following.

ACCESS SERVICE

15. Metropolitan Statistical Area Services (Cont'd)

15.5 Contract Services (Cont'd)

15.5.2 Contract Tariff Option 2 (Cont'd)

(E) Service Period

- (1) Subject to terms and conditions set forth in (E)(2) following and all other applicable terms set forth herein, the **Service Period** of this Option 2 shall commence on the date the customer subscribes to this Option 2 and end on December 31, 2015 (except that the Service Period shall include any extensions that take effect pursuant to (E)(2) following).
- (2) At the expiration of Plan Year 3 of the Service Period, and unless otherwise terminated as set forth herein, the customer may elect to extend the Service Period for one (1) year beyond expiration of the initial three (3) Plan Years of the Service Period at the Flat Rates and Premium Spend Target for Plan Year 3. Five (5) of such one (1) year extensions are permitted. For avoidance of doubt, this discretionary extension period begins January 1 of each of the subsequent years 2016, 2017, 2018, 2019 and 2020. The customer must notify the Telephone Company in writing of its election to extend the Service Period at least thirty (30) calendar days prior to the expiration date of Plan Year 3 or the end of first one (1) year extension period, as applicable.

(F) Qualifying Services

- (1) Qualifying Services will be comprised of the following:
 - (a) Special Access 1.544 Mbps Services as set forth in Section 7.8 of FCC 1, Section 7.2.6 preceding of this tariff, Section 5.2.2 of FCC 3, Section 7.2.9 of FCC 4, Section 5.3.6 of FCC 5, Section 7.11.1 of FCC 6, and Section 7 of FCC 10, in each case as the same may be amended from time to time (collectively, **DS1 Services**); and
 - (b) Special Access 44.736 Mbps Services as set forth in Section 7.8 of FCC 1, Section 7.2.6 preceding of this tariff, Section 5.2.2 of FCC 3, Section 7.2.9 of FCC 4, Section 5.3.6 of FCC 5, Section 7.11.1 of FCC 6, and Section 7 of FCC 10, in each case as the same may be amended from time to time (collectively, **DS3 Services**); and
 - (c) Special Access 1.544 Mbps and 44.736 Mbps Facilities Management Services, as described in Section 7.2.13 of FCC 4 as the same may be amended from time to time (**FMS Services**).

ACCESS SERVICE

15. Metropolitan Statistical Area Services (Cont'd)

15.5 Contract Services (Cont'd)

15.5.2 Contract Tariff Option 2 (Cont'd)

(F) Qualifying Services (Cont'd)

(1) Qualifying Services will be comprised of the following: (Cont'd)

(d) Special Access Dedicated SONET Entrance Facilities Service with a 44.736 Mbps electrical interface, as described in Section 7.2.15 of FCC 4, Section 20.4 of FCC 5, and Section 20.4 of FCC 6, in each case as the same may be amended from time to time (collectively, **DSEF Services**).

Any services other than the services explicitly listed in this (F)(1) (including any Telephone Company provided SONET entrance facility service) are not included herein as a Qualifying Service. Additionally, Qualifying Services do not include any Switched Access Services.

For purposes of this Option 2: (i) all Qualifying Service volumes and revenues are quantified according to three categories (DS1 Units, Multiplexed DS3 Units, and PTP DS3 Units) as described further in (F)(2) following; and (ii) subject to (F)(2)(d) and (F)(4) following, the USOCs set forth in (F)(2) following reflect the entire list of USOCs included in the definition of Qualifying Services and counted as contributory toward Billed Qualifying Service Revenue.

(2) Revenues Included in Calculation of Billed Qualifying Service Revenue

Subject to the exceptions and requirements set forth in this Section (F), Billed Qualifying Service Revenue includes monthly recurring charges billed to the customer under the Customer ACNAs for Billed Qualifying Service Units in the operating territories of this tariff, FCC 1, FCC 3, FCC 4, FCC 5, FCC 6, and FCC 10. **Billed DS1 Qualifying Service Revenue** is described in (F)(2)(a) following, subject to (F)(2)(d) and (F)(3) following. **Billed Multiplexed DS3 Qualifying Service Revenue** is described in (F)(2)(b) following, subject to (F)(2)(d) and (F)(3) following. **Billed PTP DS3 Qualifying Service Revenue** is described in (F)(2)(c) following, subject to (F)(2)(d) and (F)(3) following.

ACCESS SERVICE

15. Metropolitan Statistical Area Services (Cont'd)

15.5 Contract Services (Cont'd)

15.5.2 Contract Tariff Option 2 (Cont'd)

(F) Qualifying Services (Cont'd)

(2) Revenues Included in Calculation of Billed Qualifying Service Revenue (Cont'd)

(a) Billed DS1 Units

With respect to Billed DS1 Units, Billed Qualifying Service Revenue includes only MRCs billed under rate elements using one or more of the following USOCs:

1A4YS	1A5ZS	1CF21	1CF22	1CF23	1CF25
1CF33	1CF35	1CF3W	1CF41	1CF42	1CF43
1CF45	1CF51	1CF52	1CF53	1CF55	1CF61
1CF62	1CF63	1CF65	1CF71	1CF72	1CF73
1CF75	1CF81	1CF82	1CF83	1CF85	1CF91
1CF92	1CF93	1CF95	1CFA1	1CFA2	1CFA3
1CFA5	1CFB1	1CFB2	1CFB3	1CFB5	1CFC1
1CFC2	1CFC3	1CFC5	1CFR8	1CFRJ	1CFS8
1CFSJ	1CFT8	1CFTJ	1CFU8	1CFUJ	1CFV8
1CFVJ	1CKDF	1CKDX	1J53S	1J54S	1L5LS
1L5XX	1LFMX	1LFSX	1OX1X	1OX2X	1OX3X
1OX5X	1OXTX	1T58S	1X7VX	1XCDX	1Y3AC
1YWPS	7CT15	7CTDC	7FT01	7FT60	7OFFV
7TD60	A1VA1	C2X9A	C6H6X	C6H7X	CCO
CTG	DVA	EU4DF	EU4DX	EU7VX	EUEU7VX
EUEUW	EUU21	EUU22	EUU23	EUU25	EUU33
EUU35	EUU3W	EUU41	EUU42	EUU43	EUU45
EUU51	EUU52	EUU53	EUU55	EUU61	EUU62
EUU63	EUU65	EUU71	EUU72	EUU73	EUU75
EUU81	EUU82	EUU83	EUU85	EUU91	EUU92
EUU93	EUU95	EUUA1	EUUA2	EUUA3	EUUA5
EUUB1	EUUB2	EUUB3	EUUB5	EUUC1	EUUC2
EUUC3	EUUC5	EUUR8	EUURJ	EUUS8	EUUSJ
EUUT8	EUUTJ	EUUU8	EUUUJ	EUUV8	EUUVJ
EUW	HCCMF	HCCMT	HCCT4	HCCTA	HCCTV
HCHCCMT	HCHCCT4	HCHCMLT	HCM10	HCM1V	HCMF5
HCMLT	HGV1X	HGVTX	MQ1	MQ6	MQK
MXN12	MXN13	MXN15	MXN17	MXNF3	MXNF5
MXNFX	PR9PX	PR9SX	QMU	TJ4DX	TJ4DY
TJ4DZ	TMECS	TMTMECS	TNJZX	TNT3X	TNT4X
TNT8X	TNTNT3X	TNTNT4X	TNTNT8X	TQ2KM	TRG
TSP	TWTF6	TYF1X	TZGHX	VPQSP	

(N)

(N)

ACCESS SERVICE

15. Metropolitan Statistical Area Services (Cont'd)

15.5 Contract Services (Cont'd)

15.5.2 Contract Tariff Option 2 (Cont'd)

(F) Qualifying Services (Cont'd)

(2) Revenues Included in Calculation of Billed Qualifying Service Revenue (Cont'd)

(b) Billed Multiplexed DS3 Units

With respect to Billed Multiplexed DS3 Units, Billed Qualifying Service Revenue includes only MRCs billed under rate elements using one or more of the following USOCs:

1A4ZS	1A59S	1A5LX	1A5YS	1A87S	1A88S
1A89S	1C4A3	1C4A5	1C4A7	1C4B3	1C4B5
1C4B7	1C4C3	1C4C5	1C4C7	1C4D3	1C4D5
1C4D7	1C4E3	1C4E5	1C4E7	1C4F3	1C4F5
1C4F7	1C4G3	1C4G5	1C4G7	1C4H3	1C4H5
1C4H7	1C4J3	1C4J5	1C4J7	1C4K3	1C4K5
1C4K7	1CFD1	1CFD3	1CFD5	1CFD7	1CFE1
1CFE3	1CFE5	1CFE7	1CFF1	1CFF3	1CFF5
1CFF7	1CFG1	1CFG3	1CFG5	1CFG7	1CFH1
1CFH3	1CFH5	1CFH7	1CFJ1	1CFJ3	1CFJ5
1CFJ7	1CFK1	1CFK3	1CFK5	1CFK7	1CFL1
1CFL3	1CFL5	1CFL7	1CFM1	1CFM3	1CFM5
1CFM7	1CFN1	1CFN3	1CFN5	1CFN7	1CKMF
1CKNX	1CKPF	1CKSX	1L5H3	1L5LS	1L5RS
1L5XX	1LFSX	1U5PS	1Y3AD	1YA8S	1YAMS
1YWQS	7CT45	7D3D1	7OF01	7OF18	7OF36
7OF60	7OT18	7OT36	7OT60	A1VXG	ABVBA
B2CDP	B2CDV	B2CEP	B2CEV	B2CFP	C2X8A
CCO	DVA	EQUA3	EQUA5	EQUA7	EQUB3
EQUB5	EQUB7	EQUC3	EQUC5	EQUC7	EQUD3
EQUD5	EQUD7	EQUE3	EQUE5	EQUE7	EQUF3
EQUF5	EQUF7	EQUG3	EQUG5	EQUG7	EQUH3
EQUH5	EQUH7	EQUJ3	EQUJ5	EQUJ7	EQUK3
EQUK5	EQUK7	EU4MF	EU4NX	EU4PF	EU4SX
EUUD1	EUUD3	EUUD5	EUUD7	EUUE1	EUUE3
EUUE5	EUUE7	EUUF1	EUUF3	EUUF5	EUUF7
EUUG1	EUUG3	EUUG5	EUUG7	EUUH1	EUUH3
EUUH5	EUUH7	EUUJ1	EUUJ3	EUUJ5	EUUJ7
EUUK1	EUUK3	EUUK5	EUUK7	EUUL1	EUUL3
EUUL5	EUUL7	EUUM1	EUUM3	EUUM5	EUUM7
EUUN1	EUUN3	EUUN5	EUUN7	FQYU1	FQYU2
FQYU3	FQYU4	FQYU5	FQYU6	GMGX3	HCM31

(N)

ACCESS SERVICE

15. Metropolitan Statistical Area Services (Cont'd)

15.5 Contract Services (Cont'd)

15.5.2 Contract Tariff Option 2 (Cont'd)

(F) Qualifying Services (Cont'd)

(2) Revenues Included in Calculation of Billed Qualifying Service Revenue (Cont'd)

(b) Billed Multiplexed DS3 Units (Cont'd)

HF12A	HF12F	HF3EA	HF3OA	HF3OF	HFCMF
HFCMT	HFCT1	HFCT4	HFCTA	HFCTV	HFHFCMT
HFHFCT4	HFMF1	HFMF3	HFMF5	HFOT4	HFOTA
HFUEA	HFUEF	HFUOA	HFUOF	HKTJS	HKTJX
HKTLS	MKM	MKW3X	MQ3	MXNM3	MXNM5
MXNMX	MXNRX	N2M	NDPCM	NDPDM	P8T13
P8T15	P8T33	P8T35	PR9SX	SLHA1	SLHA3
SLHA5	SLHA7	SLHB1	SLHB3	SLHB5	SLHB7
SLHC1	SLHC3	SLHC5	SLHC7	SLHD1	SLHD3
SLHD5	SLHD7	SLHE1	SLHE3	SLHE5	SLHE7
T7TAX	T8XJ3	T8XJ5	TJ4EX	TJ4EY	TJ4EZ
TJ59X	TKTPX	TNW3X	TNW5X	TNWZX	TQ2LM
TRG	TSP	TUTFX	TUTPX	TUTUTPX	TWBNX
TWBPX	TWTF7	TYF3S	TYF3X	TYF8S	TYF8X
TYFLS	TYFLX	TYFMS	TYFMX	TYFNX	TYFOX
TYFPX	TYFQX	TYFRX	TYFSX	TYFTX	TYFUX
TYFVS	TYFVX	TYFWS	TYFWX	TYTYF8X	TYTYFLS

DSEF USOCs mapped to Billed Multiplexed DS3 Units will be included in the Billed Qualifying Service Revenue for those Units.

(N)

(N)

ACCESS SERVICE

15. Metropolitan Statistical Area Services (Cont'd)

15.5 Contract Services (Cont'd)

15.5.2 Contract Tariff Option 2 (Cont'd)

(F) Qualifying Services (Cont'd)

(2) Revenues Included in Calculation of Billed Qualifying Service Revenue (Cont'd)

(c) Billed PTP DS3 Units

With respect to Billed PTP DS3 Units, Billed Qualifying Service Revenue includes only MRCs billed under rate elements using one or more of the following USOCs:

1A4ZS	1A59S	1A5LX	1A5YS	1A87S	1A88S
1A89S	1C4A3	1C4A5	1C4A7	1C4B3	1C4B5
1C4B7	1C4C3	1C4C5	1C4C7	1C4D3	1C4D5
1C4D7	1C4E3	1C4E5	1C4E7	1C4F3	1C4F5
1C4F7	1C4G3	1C4G5	1C4G7	1C4H3	1C4H5
1C4H7	1C4J3	1C4J5	1C4J7	1C4K3	1C4K5
1C4K7	1CFD1	1CFD3	1CFD5	1CFD7	1CFE1
1CFE3	1CFE5	1CFE7	1CFF1	1CFF3	1CFF5
1CFF7	1CFG1	1CFG3	1CFG5	1CFG7	1CFH1
1CFH3	1CFH5	1CFH7	1CFJ1	1CFJ3	1CFJ5
1CFJ7	1CFK1	1CFK3	1CFK5	1CFK7	1CFL1
1CFL3	1CFL5	1CFL7	1CFM1	1CFM3	1CFM5
1CFM7	1CFN1	1CFN3	1CFN5	1CFN7	1CKMF
1CKNX	1CKPF	1CKSX	1L5H3	1L5LS	1L5RS
1L5XX	1LFSX	1U5PS	1Y3AD	1YA8S	1YAMS
1YWQS	7CT45	7OF01	7OF18	7OF36	7OF60
7OT18	7OT36	7OT60	A1VXG	ABVBA	B2CDP
B2CDV	B2CEP	B2CEV	B2CFP	C2X8A	CCO
DVA	EQUA3	EQUA5	EQUA7	EQUB3	EQUB5
EQUB7	EQUC3	EQUC5	EQUC7	EQU3D	EQU3D5
EQU3D7	EQUE3	EQUE5	EQUE7	EQUF3	EQUF5
EQUF7	EQU3G	EQU3G5	EQU3G7	EQUH3	EQUH5
EQUH7	EQUJ3	EQUJ5	EQUJ7	EQUK3	EQUK5
EQUK7	EU4MF	EU4NX	EU4PF	EU4SX	EUUD1
EUUD3	EUUD5	EUUD7	EUUE1	EUUE3	EUUE5
EUUE7	EUUF1	EUUF3	EUUF5	EUUF7	EUUG1
EUUG3	EUUG5	EUUG7	EUUH1	EUUH3	EUUH5
EUUH7	EUUJ1	EUUJ3	EUUJ5	EUUJ7	EUUK1
EUUK3	EUUK5	EUUK7	EUUL1	EUUL3	EUUL5
EUUL7	EUUM1	EUUM3	EUUM5	EUUM7	EUUN1
EUUN3	EUUN5	EUUN7	FQYU1	FQYU2	FQYU3

(N)

(N)

ACCESS SERVICE

15. Metropolitan Statistical Area Services (Cont'd)

15.5 Contract Services (Cont'd)

15.5.2 Contract Tariff Option 2 (Cont'd)

(F) Qualifying Services (Cont'd)

(2) Revenues Included in Calculation of Billed Qualifying Service Revenue (Cont'd)

(c) Billed PTP DS3 Units (Cont'd)

FQYU4	FQYU5	FQYU6	GMGX3	HF12A	HF12F
HF3EA	HF3OA	HF3OF	HFCMF	HFCMT	HFCT1
HFCT4	HFCTA	HFCTV	HFHFCMT	HFHFCT4	HFMF1
HFMF3	HFMF5	HFOT4	HFOTA	HFUEA	HFUEF
HFUOA	HFUOF	HKTJS	HKTJX	HKTLS	MXNM5
N2M	NDPCM	NDPDM	P8T13	P8T15	P8T33
P8T35	PR9SX	SLHA1	SLHA3	SLHA5	SLHA7
SLHB1	SLHB3	SLHB5	SLHB7	SLHC1	SLHC3
SLHC5	SLHC7	SLHD1	SLHD3	SLHD5	SLHD7
SLHE1	SLHE3	SLHE5	SLHE7	T7TAX	T8XJ3
T8XJ5	TJ4EX	TJ4EY	TJ4EZ	TJ59X	TKTPX
TNW3X	TNW5X	TNWZX	TQ2LM	TRG	TSP
TUTFX	TUTPX	TUTUTPX	TWBNX	TWBPX	TWTF7
TYF3S	TYF3X	TYF8S	TYF8X	TYFLS	TYFLX
TYFMS	TYFMX	TYFNX	TYFOX	TYFPX	TYFQX
TYFRX	TYFSX	TYFTX	TYFUX	TYFVS	TYFVX
TYFWS	TYFWX	TYTYF8X	TYTYFLS		

DSEF USOCs mapped to Billed PTP DS3 Units will be included in the Billed Qualifying Service Revenue for those Units.

- (d) If any of the USOCs listed in (F)(2)(a) through (F)(2)(c) preceding bill both MRCs and other charges (e.g., NRCs), then only the MRC amounts (i.e., only those amounts appearing in the MRC section of the customer's bill from the Telephone Company) of such USOCs shall be counted towards the calculation of Billed Qualifying Service Revenue.

ACCESS SERVICE

15. Metropolitan Statistical Area Services (Cont'd)

15.5 Contract Services (Cont'd)

15.5.2 Contract Tariff Option 2 (Cont'd)

(F) Qualifying Services (Cont'd)

(3) Examples of Revenues Not Included in Calculation of Billed Qualifying Service Revenue

Billed Qualifying Service Revenue does not include (the following list being illustrative only) any of the following:

- (a) any non-recurring charges (**NRCs**), surcharges, taxes, late payment charges, credits (including any credits provided herein), fractional debit/credit amounts, adjustments, minimum period charges, termination liabilities, or any other billings other than billed amounts that are applied on a recurring monthly basis for the applicable Quarter or Plan Year of the Service Period;
- (b) taxes, or other charges imposed by a federal, state, local, or other governmental entity (e.g., Federal Universal Service Fund);
- (c) service or administrative fees or charges imposed by the Telephone Company (e.g. interest penalty, late payment penalty);
- (d) any amount that appears in the Other Charges and Credits section of the Telephone Company's bill to the customer (e.g., prorated charges);
- (e) any other charges that are not applied on a monthly recurring basis and/or do not appear in the MRC section (typically labeled "Monthly Access Charges") of the Telephone Company's bill to the customer;
- (f) any amount for which payment is being withheld by the customer or for which the Telephone Company has issued a credit in response to a customer dispute;
- (g) any amount billed under a particular bill for services provided outside of the service period that is ordinarily covered by such bill;
- (h) shortfall or overage charges associated with Existing Plan scheduled reviews/true-ups (e.g., for failure to satisfy commitment levels pursuant to a CDP);
- (i) billed amounts associated with any service (or any portion of a service) that is not a Qualifying Service;
- (j) any Quarterly Billing Credits or other Credits that the customer receives in connection with (H) following.

ACCESS SERVICE

15. Metropolitan Statistical Area Services (Cont'd)

15.5 Contract Services (Cont'd)

15.5.2 Contract Tariff Option 2 (Cont'd)

(F) Qualifying Services (Cont'd)

(4) USOC Updates

If, during the Service Period, the Telephone Company revises Section 7 preceding of this tariff, Section 7 of FCC 1, Section 7 of FCC 4, Section 5 of FCC 3, Section 5 of FCC 5, Section 7 of FCC 6, or Section 7 of FCC 10 to (i) replace or substitute a USOC for a rate element of a Qualifying Service as set forth in (F)(2) preceding; or (ii) add a USOC for a rate element of a Qualifying Service as used herein that was inadvertently omitted from this tariff, then (effective as of the date on which such revision becomes effective) such new USOC shall be included in the definition of the applicable Qualifying Service(s) and such new USOC, provided it otherwise qualifies to be contributory under (F)(2) and (F)(3) preceding and all other terms set forth herein, will be counted as contributory towards Billed Qualifying Service Revenue.

(G) Serving Area

Notwithstanding any other provision set forth herein, any Quarterly Billing Adjustments or other credits will be provided only in the MSAs that have achieved Phase I or Phase II pricing flexibility under Section 14.3 of FCC 4, Section 15 of this tariff, and Section 19.1 of FCC 5. Wire centers for the Phase II MSAs are listed in Section 14.3 of FCC 4 and Section 19.1 of FCC 5. Any additions of, or changes to, the MSAs (including changes to wire centers or Level 1/Level 2 pricing status as described in Section 14.3 of FCC 4 and Section 19.1 of FCC 5) that occur during the Service Period will apply. No Quarterly Billing Adjustments or other credits will be provided in the operating territories of FCC 1, FCC 3, FCC 6, or FCC 10.

ACCESS SERVICE

15. Metropolitan Statistical Area Services (Cont'd)

15.5 Contract Services (Cont'd)

15.5.2 Contract Tariff Option 2 (Cont'd)

(H) Calculation and Payment of Quarterly Billing Adjustments

The customer will receive a Final Quarterly Billing Adjustment based on a two phase process. Phase 1 consists of a Flat Rate Billing Adjustment, and Phase 2 consists of a Premium Spend Adjustment.

(1) Rate Calculation Methodology for Flat Rate Pricing

The Flat Rate pricing for Qualifying Services under this Option 2 shall be achieved by applying a discount to the average revenue per Billed DS1 Unit, per Billed Multiplexed DS3 Unit, and per Billed PTP DS3 Unit using the calculation [average revenue per Billed Qualifying Service Unit x (1 – discount)] as follows:

(a) DS1 Flat Rate Pricing

(Step 1) Calculate the average revenue per DS1 Unit (**DS1 ARPU**) by summing (i) the total MRC associated with the customer's Qualifying DS1 Services for which the customer was billed by the Telephone Company for the month of July 2012 and dividing by (ii) the total number of the DS1 Units for such DS1 Qualifying Services during the same period of time.

The DS1 ARPU calculated in this Step 1 is used to determine the Flat Rate per DS1 Unit for each Plan Year of the Service Period.

(Step 2) To determine the Flat Rate per Billed DS1 Unit, multiply (i) the DS1 ARPU determined in Step 1; by (ii) 1 minus the discount for the applicable Plan Year from Table 1 below.

Table 1

<u>Plan Year</u>	<u>Discount</u>
1	24.22%
2	24.22%
3	25.13%

ACCESS SERVICE

15. Metropolitan Statistical Area Services (Cont'd)

15.5 Contract Services (Cont'd)

15.5.2 Contract Tariff Option 2 (Cont'd)

(H) Calculation and Payment of Quarterly Billing Adjustments (Cont'd)

(1) Rate Calculation Methodology for Flat Rate Pricing (Cont'd)

(b) Multiplexed DS3 Flat Rate Pricing

(Step 1) Calculate the average revenue per Multiplexed DS3 Unit (**Multiplexed DS3 ARPU**) by summing (i) the total MRC associated with the customer's Qualifying Multiplexed DS3 Services for which the customer was billed by the Telephone Company for the month of July 2012 and dividing by (ii) the total number of the Multiplexed DS3 Units for such Multiplexed DS3 Qualifying Services during the same period of time.

The Multiplexed DS3 ARPU calculated in this Step 1 is used to determine the Flat Rate per Multiplexed DS3 Unit for each Plan Year of the Service Period.

(Step 2) To determine the Flat Rate per Billed Multiplexed DS3 Unit, multiply (i) the Multiplexed DS3 ARPU calculated in Step 9; by (ii) one (1) minus the discount for the applicable Plan Year from Table 2 below [Multiplexed DS3 ARPU x (1 – discount)].

Table 2

<u>Plan Year</u>	<u>Discount</u>
1	25.80%
2	25.80%
3	25.80%

ACCESS SERVICE

15. Metropolitan Statistical Area Services (Cont'd)

15.5 Contract Services (Cont'd)

15.5.2 Contract Tariff Option 2 (Cont'd)

(H) Calculation and Payment of Quarterly Billing Adjustments (Cont'd)

(1) Rate Calculation Methodology for Flat Rate Pricing (Cont'd)

(c) PTP DS3 Flat Rate Pricing

(Step 1) Calculate the average revenue per PTP DS3 Unit (**PTP DS3 ARPU**) by summing (i) the total MRC associated with the customer's Qualifying PTP DS3 Services for which the customer was billed by the Telephone Company for the month of July 2012 and dividing by (ii) the total number of the PTP DS3 Units for such PTP DS3 Qualifying Services during the same period of time.

The PTP DS3 ARPU calculated in this Step 1 is used to determine the Flat Rate per PTP DS3 Unit for each Plan Year of the Service Period.

(Step 2) To determine the Flat Rate per Billed PTP DS3 Unit, multiply (i) the PTP DS3 ARPU calculated in Step 9; by (ii) one (1) minus the discount for the applicable Plan Year from Table 2 below [PTP DS3 ARPU x (1 – discount)].

Table 3

<u>Plan Year</u>	<u>Discount</u>
1	23.37%
2	23.37%
3	23.37%

ACCESS SERVICE

15. Metropolitan Statistical Area Services (Cont'd)

15.5 Contract Services (Cont'd)

15.5.2 Contract Tariff Option 2 (Cont'd)

(H) Calculation and Payment of Quarterly Billing Adjustments (Cont'd)

(2) Phase I: Calculation of the Flat Rate Billing Adjustment

To calculate the Quarterly Flat Rate Billing Adjustment:

- Step 1 Determine the total number of Billed DS1 Units, Billed Multiplexed DS3 Units, and Billed PTP DS3 Units for the Quarter in accordance with (H)(1) preceding.
- Step 2 Determine the Billed Qualifying Service Revenue for the Quarter for each Qualifying Service type (i.e., based on Billed DS1 Units, Billed Multiplexed DS3 Units, and Billed PTP DS3 Units) in accordance with (H)(1) preceding.
- Step 3 Calculate the Flat Rate for the Quarter for each Qualifying Service type (DS1, Multiplexed DS3, and PTP DS3) in accordance with (H)(1) preceding.
- Step 4 Calculate the Flat Rate Spend for each Qualifying Service type (DS1, Multiplexed DS3, and PTP DS3) by multiplying the Flat Rate determined in Step 3 by the Billed Units determined in Step 1.
- Step 5 Calculate the Quarterly Flat Rate Billing Adjustment for each Qualifying Service type (DS1, Multiplexed DS3, and PTP DS3) by and subtracting the Flat Rate Spend determined in Step 4 from the total of the applicable Billed Qualifying Service Revenue determined in Step 2. This Quarterly Flat Rate Billing Adjustment will be a credit if the Billed Qualifying Service Revenue is higher than the Flat Rate Spend or a debit if the the Billed Qualifying Service Revenue is lower than the Flat Rate Spend.

To the extent that the customer fails to pay any amounts due to Telephone Company for Qualifying Services under this Option 2, excluding bill disputes, Telephone Company may offset such amounts against any Quarterly Billing Adjustments owed to Customer by Telephone Company under this Option 2.

ACCESS SERVICE

15. Metropolitan Statistical Area Services (Cont'd)

15.5 Contract Services (Cont'd)

15.5.2 Contract Tariff Option 2 (Cont'd)

(H) Calculation and Payment of Quarterly Billing Adjustments (Cont'd)

(3) Phase II: Calculation of the Spend Premium Adjustment

To calculate the Spend Premium Adjustment:

- Step 1 Calculate the Total Baseline Reference Spend by multiplying the Billed Units for each Qualifying Service Type (DS1, Multiplexed DS3, and PTP DS3) by the Baseline Unit Reference Cost for each Qualifying Service Type (DS1, Multiplexed DS3, and PTP DS3), and summing the results.
- Step 2 Calculate the Quarterly Spend Premium by subtracting the Total Baseline Reference Spend from the Quarterly Total Flat Rate Spend, which is the sum of the Flat Rate Spends by Qualifying Service Type calculated in (H)(2) preceding
- Step 3 Compare the Quarterly Spend Premium to the Quarterly Spend Premium Target for the applicable year found in Table 4 below. The resulting difference ("Quarterly Spend Premium Adjustment") will be a credit if the Quarterly Spend Premium is higher than the Quarterly Spend Premium Target or a debit if the Quarterly Spend Premium is lower than the Quarterly Spend Premium Target.

Table 4

<u>Plan Year</u>	<u>Premium Spend Target</u>
1	\$3.75M per quarter (\$15M Annually)
2	\$3.75M per quarter (\$15M Annually)
3	\$3.25M per quarter (\$13M Annually)

(4) Final Quarterly Billing Adjustment

The Telephone Company will net the Quarterly Flat Rate Billing Adjustment and the Quarterly Spend Premium Adjustment determined in (H)(2) and (H)(3) preceding. If the net result is a credit, the Telephone Company will provide a credit on its invoice to the customer within 120 calendar days after the end of the applicable Quarter, and if the net result is a debit, the Telephone Company will bill the net debit to the customer within 120 days after the end of the applicable Quarter.

ACCESS SERVICE

15. Metropolitan Statistical Area Services (Cont'd)

15.5 Contract Services (Cont'd)

15.5.2 Contract Tariff Option 2 (Cont'd)

(I) Limitation on Grooms

There shall be no limits on number of Grooms for Qualifying Services.

(J) Suspension of True-ups and Extension of Existing Plans During Service Period

During the Service Period, the customer's Existing Plans as defined in (C)(4) preceding, shall be subject to the following provisions (both as to Qualifying Services as well as all other services covered by such Existing Plans):

(1) Suspension of True-ups

The scheduled review/true-up requirements for the customer's Existing Plans, and FMS Plans, if applicable, including any shortfall payments or penalties that would otherwise result for failure to maintain volume commitments, shall be suspended during the Service Period. Upon termination of the customer's subscription to this Option 2, Option 63 of FCC 4, or Option 32 of FCC 5 for any reason, the review/true-up requirements shall be re-activated for the Existing Plans and new commitments shall be established in accordance with the regulations for the type of Existing Plan involved. For Existing Plans, Time-In-Service-Credits (**TISC**), when applicable, will be granted based on credit already earned as of January 1, 2013 plus any additional credit earned during the customer's subscription to this Option 2, Option 63 of FCC 4, or Option 32 of FCC 5, which collectively shall not be greater than the TISC available under the terms of the applicable Existing Plan.

(2) Extension of Existing Plans

Subject to any early termination of the customer's subscription to this Option 2, Option 63 of FCC 4, or Option 32 of FCC 5, the Existing Plans are deemed extended as necessary to be coterminous with the Service Period. Upon expiration of the Service Period, the Existing Plans will be subject to the regulations for the type of Existing Plan involved that ordinarily apply upon expiration of the respective Existing Plans (including establishment of new commitments). TISC will be granted based on credit already earned as of January 1, 2013 plus any additional credit earned during the customer's subscription to this Option 2, Option 63 of FCC 4, or Option 32 of FCC 5, which collectively shall not be greater than the TISC available under the terms of the applicable Existing Plan.

(3) Other Tariff Provisions

All other terms and conditions applicable to the Existing Plans (including discounts and minimum period requirements) remain unchanged by this Section (J).

ACCESS SERVICE

15. Metropolitan Statistical Area Services (Cont'd)

15.5 Contract Services (Cont'd)

15.5.2 Contract Tariff Option 2 (Cont'd)

(K) Mergers, Acquisitions, Divestitures, and Other Changes in Control of Customer

(1) Sale or Other Transfer of Ownership From the Customer to an Unaffiliated Third Party

If the customer sells to an unaffiliated third party, or otherwise transfers to an unaffiliated third party its ownership of (collectively, a **Third Party Sale**), one or more Customer ACNA(s), or a line of business, division, affiliate, or license to operate in a particular geographic area (e.g., a Commercial Mobile Radio Service (CMRS) license) (collectively, **Sold Properties**), then the terms and conditions set forth in this Section (K) shall apply to account for the effect of such Third Party Sale on this Option 2:

(a) No later than sixty (60) calendar days prior to closure of the Third Party Sale, the customer shall notify the Telephone Company of such Third Party Sale via a written notice that includes the following information:

- (1) the date on which the Third Party Sale is expected to close; and
- (2) the affected Customer ACNA(s); and
- (3) the affected state(s) or other relevant geographic area(s); and
- (4) Information sufficient to begin the identification process of the volumes and circuit identifiers of all DS1 Units, Multiplexed DS3 Units, and PTP DS3 Units associated with the Sold Properties that the customer will no longer obtain from the Telephone Company as a result of the Third Party Sale (**Sold Qualifying Units**). After sending this notification, the customer will work cooperatively with the Telephone Company (and the third-party carrier, if necessary) to complete the exchange of this information.

(b) If the customer provides notice as described in (K)(1)(a) preceding, then effective upon closure of the Third Party Sale if such closure occurs on the first day of a calendar month (or effective upon the first day of the calendar month following closure of the Third Party Sale if such closure occurs on a day other than the first day of a calendar month): (i) all Sold Qualifying Units shall not be counted as Billed Qualifying Service Units, shall not be eligible for the Quarterly Billing Adjustments, and shall cease to be covered by this Option 2 for all other purposes, and (ii) the Flat Rates and Quarterly Spend Premium Targets shall be proportionally adjusted to account for the reduced number of ACNAs covered by this Option 2, Option 63 of FCC 4, and Option 32 of FCC 5.

ACCESS SERVICE

15. Metropolitan Statistical Area Services (Cont'd)

15.5 Contract Services (Cont'd)

15.5.2 Contract Tariff Option 2 (Cont'd)

(K) Mergers, Acquisitions, Divestitures, and Other Changes in Control of Customer (Cont'd)

(2) Mergers and Acquisitions of the Customer

- (a) In the event the customer merges with another company or acquires a company or a portion of the business of another company (including any ACNA(s) that are not Customer ACNAs) (the company with which the customer merges and the company or portion of the business thereof that the customer acquires (including an ACNA(s) that is not a Customer ACNA(s)) may be referred to collectively as the **Customer Acquired Properties** and such merger or acquisition may be referred to in either case as an **Acquisition**), and the Telephone Company provides any Qualifying Services in connection with such Customer Acquired Properties, then the customer shall notify the Telephone Company prior to the closing of the Acquisition and the Parties shall determine whether the Customer Acquired Properties shall be included in or excluded from the terms and conditions (including the calculation of Quarterly Billing Adjustment) of this Option 2, Option 63 of FCC 4, and Option 32 of FCC 5. No Customer Acquired Properties shall be included in these contract tariffs absent the mutual agreement of the Parties.
- (b) The Parties shall work cooperatively and in good faith with each other to take such action as may be necessary to achieve the intent of this Section (K), and neither Party shall unreasonably withhold from the other Party any data that is necessary or reasonably required to achieve such intent.

(N)

(X)

(N)

ACCESS SERVICE

15. Metropolitan Statistical Area Services (Cont'd)

15.5 Contract Services (Cont'd)

15.5.2 Contract Tariff Option 2 (Cont'd)

(L) Sale or Acquisition of Properties by the Telephone Company

(1) Sale of an Operating Telephone Company

- (a) In the event that the Telephone Company sells all or part of one of its operating telephone companies (a **Sold Operating Company**) that provides Qualifying Services under this tariff, FCC 1, FCC 3, FCC 4, FCC 5, FCC 6 or FCC 10 during the Service Period (a **Property Sale**), the terms and conditions set forth in this Section (L) shall apply.
- (b) Prior to closure of the Property Sale or as expeditiously as practical after such closure, the Telephone Company shall notify the customer of such Property Sale via a written notice, which shall include the date on which the Property Sale is expected to close (or has closed) and the affected state(s) or other relevant geographic area(s).
- (c) Effective upon closure of the Property Sale if such closure occurs on the first day of a calendar month (or effective upon the first day of the calendar month following closure of the Property Sale if such closure occurs on a day other than the first day of a calendar month), all DS1 Units, Multiplexed DS3 Units, and PTP DS3 Units associated with the Sold Operating Company shall not be counted as Billed Qualifying Service Units, shall not be eligible for the Flat Rates, and shall cease to be covered by this Option 2, Option 63 of FCC 4, and Option 32 of FCC 5 for all other purposes, and the Flat Rates and Quarterly Spend Premium Targets shall be proportionally adjusted to account for the reduced operating territory covered by this Option 2, Option 63 of FCC 4, and Option 32 of FCC 5.

ACCESS SERVICE

15. Metropolitan Statistical Area Services (Cont'd)

15.5 Contract Services (Cont'd)

15.5.2 Contract Tariff Option 2 (Cont'd)

(L) Sale or Acquisition of Properties by the Telephone Company (Cont'd)

(2) Mergers and Acquisitions of the Telephone Company

- (a) In the event the Telephone Company merges with another company, acquires a company or a portion of the business of another company, or is acquired in whole or in part by another company (the company with which the Telephone Company merges, the company or portion of the business thereof that the Telephone Company acquires, and the company that acquires the Telephone Company in whole or in part may be referred to collectively as the **Acquired Properties** and such merger or acquisition may be referred to in either case as a **Telco Acquisition**), the Telephone Company shall determine whether such Acquired Properties shall be included in or excluded from the terms and conditions (including the calculation of Quarterly Billing Adjustments) of this Option 2, Option 63 of FCC 4, and Option 32 of FCC 5 in accordance with (b) following.
- (b) The Parties shall work cooperatively to determine whether such Acquired Properties shall be included in or excluded from this Option 2, Option 63 of FCC 4, and Option 32 of FCC 5. No Acquired Properties shall be included in these contract tariffs absent the mutual agreement of the Parties.

ACCESS SERVICE

15. Metropolitan Statistical Area Services (Cont'd)

15.5 Contract Services (Cont'd)

15.5.2 Contract Tariff Option 2 (Cont'd)

(M) Termination

(1) Mutual Agreement

The Parties, by mutual written agreement in their sole discretion, may terminate the customer's subscription to this Option 2. Except as otherwise mutually agreed in writing by the Parties, any termination under this Section (M)(1) shall be effective as of the end of the Plan Year preceding the termination. Termination of the customer's subscription to this Option 2 shall be an automatic termination of the customer's subscription to Option 63 of FCC 4 and Option 32 of FCC 5. Upon any such termination, the customer shall be entitled to all Quarterly Billing Adjustments for the Plan Year preceding the termination, but shall not be eligible for any Quarterly Billing Adjustments for any period of time after the end of such Plan Year.

(N) Expiration of the Service Period

Upon expiration of Service Period (including any extensions permitted under (E)(2) preceding), the customer has the following options:

(1) continue with the services under the Existing Plans, in which case the review/true-up requirements shall be re-activated in accordance with (J)(1) preceding; or

(2) Subject to the re-activation of Existing Plans as set forth in (J) preceding, disconnect the services without the application of termination liability under this Option 2. In accordance with termination requirements set forth in the Existing Plans which the services are subscribed to, termination charges may apply under such Existing Plans upon any such disconnection.

ACCESS SERVICE

16. Rates and Charges

Rates and charges for Access Service set forth below apply to all of the Issuing Carriers shown on Title Pages 2 through 5.

16.1 RESERVED FOR FUTURE USE

ACCESS SERVICE

16. Rates and Charges (Cont'd)

16.2 RESERVED FOR FUTURE USE

ACCESS SERVICE

16. Rates and Charges (Cont'd)

16.3 Access Ordering

Service Order Charges

Service Charge	\$66.00		
Additional Line Charge	\$44.00		
Service Date Change Charge	\$50.00		
Design Change Charge			
Alabama	\$10,946.23	(C)	
Florida	\$10,946.23		
Georgia	\$10,946.23		
Illinois	\$10,946.23		
Indiana	\$10,946.23		
Michigan	\$10,946.23		
New York	\$10,946.23		
Ohio	\$10,946.23		
Pennsylvania	\$10,946.23		
Wisconsin	\$10,946.23		(C)
Expedited Order Charge per order, per day advanced	\$300.00		

ACCESS SERVICE

16. Rates and Charges (Cont'd)

16.4 RESERVED FOR FUTURE USE

ACCESS SERVICE

16. Rates and Charges (Cont'd)

16.4 Reserved

ACCESS SERVICE

16. Rates and Charges (Cont'd)

16.4 RESERVED FOR FUTURE USE

ACCESS SERVICE

16. Rates and Charges (Cont'd)

16.4 RESERVED FOR FUTURE USE

ACCESS SERVICE

16. Rates and Charges (Cont'd)

16.4 RESERVED FOR FUTURE USE

ACCESS SERVICE

16. Rates and Charges (Cont'd)

16.4 RESERVED FOR FUTURE USE

ACCESS SERVICE

16. Rates and Charges (Cont'd)

16.5 Special Access, Competitive Counties

Surcharge for Special Access Service

rate per Voice Grade Equivalent channel

Rochester	\$0.00
All Other Companies	\$25.00

Metallic Service

Channel Termination

rate per termination, per month

Rochester	\$150.00
Illinois	\$150.00
Midland	\$150.00
Mt. Pulaski	\$150.00
Lakeside	\$150.00
Prairie	\$150.00
Schuler	\$150.00
Orion	\$150.00
All Other Companies	\$150.00

Nonrecurring Charge

Rochester	\$1,000.00
Illinois	\$1,000.00
Midland	\$1,000.00
Mt. Pulaski	\$1,000.00
Lakeside	\$1,000.00
Prairie	\$1,000.00
Schuler	\$1,000.00
Orion	\$1,000.00
All Other Companies	\$1,000.00

ACCESS SERVICE

16. Rates and Charges (Cont'd)

16.5 Special Access (Cont'd)

Metallic Service (Cont'd)

Channel Mileage

Channel Mileage Facility, per mile, per month

Rochester \$12.00

All Other Companies \$12.00

Channel Mileage Termination, per termination, per month

Rochester \$0.00

Illinois \$40.00

Midland \$57.21

Mt. Pulaski \$10.24

Lakeside \$73.58

Schuler \$54.80

Orion \$33.53

All Other Companies \$0.00

Optional Features & Functions

Bridging, per port per month

Three premises bridging, Rochester ICB

Series bridging, Rochester ICB

ACCESS SERVICE

16. Rates and Charges (Cont'd)

16.5 Special Access, Competitive Counties (Cont'd)

Telegraph Grade Service

Channel Termination

rate per termination, per month

Rochester \$150.00

All Other Companies \$150.00

Nonrecurring Charge

Rochester \$1,000.00

All Other Companies \$1,000.00

Channel Mileage

Channel Mileage Facility, per mile, per month

Rochester \$12.00

All Other Companies \$12.00

Channel Mileage Termination, per termination, per month

Rochester \$0.00

All Other Companies \$0.00

Optional Features & Functions

Bridging, per port per month

Three premises bridging, Rochester ICB

Series bridging, Rochester ICB

ACCESS SERVICE

16. Rates and Charges (Cont'd)

16.5 Special Access, Competitive Counties (Cont'd)

Voice Grade Service

Channel Termination –

Two-wire rate per termination, per month

- Competitive Exchanges – End User (C)

- IC CDL – includes Non-Competitive Exchanges

Rochester, NY	\$2,738.37
FC of IL, IL	\$6,496.74
Midland, IL	\$8,899.87
Mt. Pulaski IL	\$1,873.15
Lakeside, IL	\$8,899.87
Prairie, IL	\$8,899.87
Schuyler, IL	\$8,899.87
Orion, IL	\$6,409.29
AuSable, NY	\$5,476.80
Breezewood, PA	\$5,476.80
Canton, PA	\$5,476.80
FC of Michigan, MI	\$5,476.80
FC of Pennsylvania, PA	\$5,476.80
FC of Georgia, GA	\$5,476.80
FC of New York, NY	\$5,476.80
Lakewood, PA	\$5,476.80
FC of Wisconsin, WI	\$5,476.80
Mondovi, WI	\$5,476.80
FC of the South, AL	\$5,476.80
Oswayo, PA	\$5,476.80
Seneca Gorham	\$5,476.80
FC of the South, FL and AL (study areas OCN 4464,4465)	\$5,476.80
Sylvan, NY	\$5,476.80
Thorntown, IN	\$5,476.80
FC of WI, WI (WI Study area OCN 0964)	\$5,476.80

Four-wire rate per termination, per month

- Competitive Exchanges – End User

- IC CDL– includes Non-Competitive Exchanges

Rochester, NY	\$4,381.58
FC of Illinois, IL	\$8,899.87
Midland, IL	\$8,899.87
Mt. Pulaski, IL	\$2,997.12
Lakeside, IL	\$8,899.87
Prairie, IL	\$8,899.87
Schuyler, IL	\$8,899.87
Orion, IL	\$8,899.87
AuSable, NY	\$8,899.87
Breezewood, PA	\$8,899.87
Canton, PA	\$8,899.87
FC of Michigan, MI	\$8,899.87
FC of Pennsylvania, PA	\$8,899.87
FC of Georgia, GA	\$8,899.87

(C)

ACCESS SERVICE

16. Rates and Charges (Cont'd)

16.5 Special Access, Competitive Counties (Cont'd)

Voice Grade Service

Channel Termination – (cont'd)

Four-wire rate per termination, per month

- Competitive Exchanges – End User
- IC CDL– includes Non-Competitive Exchanges (cont'd)

FC of New York, NY	\$8,899.87	(C)
Lakewood, PA	\$8,899.87	
FC of Wisconsin, WI	\$8,899.87	
Mondovi, WI	\$8,899.87	
FC of the South, AL	\$8,899.87	
Oswayo, PA	\$8,899.87	
Seneca Gorham	\$8,899.87	
FC of the South, FL and AL (study areas OCN 4464,4465)	\$8,899.87	
Sylvan, NY	\$8,899.87	
Thorntown, IN	\$8,899.87	
FC of WI, WI (WI Study area OCN 0964)	\$8,899.87	

Nonrecurring Charge –

Rochester, NY	\$58,190.44	
FC of Illinois, IL	\$10,953.46	
Midland, IL	\$10,953.46	
Mt. Pulaski, IL	\$10,953.46	
Lakeside, IL	\$10,953.46	
Prairie, IL	\$10,953.46	
Schuyler, IL	\$10,953.46	
Orion, IL	\$10,953.46	
AuSable, NY	\$59,559.94	
Breezewood, PA	\$59,559.94	
Canton, PA	\$59,559.94	
FC of Michigan, MI	\$59,559.94	
FC of Pennsylvania, PA	\$59,559.94	
FC of Georgia, GA	\$59,559.94	
FC of New York, NY	\$59,559.94	
Lakewood, PA	\$59,559.94	
FC of Wisconsin, WI	\$59,559.94	
Mondovi, WI	\$59,559.94	
FC of the South, AL	\$59,559.94	
Oswayo, PA	\$59,559.94	
Seneca Gorham	\$59,559.94	
FC of the South, FL and AL (study areas OCN 4464,4465)	\$59,559.94	
Sylvan, NY	\$59,559.94	
Thorntown, IN	\$59,559.94	
FC of WI, WI3 (WI Study area OCN 0964)	\$59,559.94	(C)

ACCESS SERVICE

16.	<u>Rates and Charges (Cont'd)</u>		
16.5	<u>Special Access, Competitive Counties (Cont'd)</u>		
	<u>Voice Grade Service (Cont'd)</u>		
	<u>Channel Mileage – includes Non-Competitive Exchanges</u>		
	Channel Mileage Facility, per mile, per month		
	Rochester, NY	\$1,643.22	(C)
	FC of Illinois, IL	\$1,610.14	
	Midland, IL	\$1,048.85	
	Mt. Pulaski, IL	\$875.09	
	Lakeside, IL	\$1,591.00	
	Schuyler, IL	\$1,028.23	
	Orion, IL	\$507.92	
	Prairie, IL	\$1,643.22	
	AuSable, NY	\$1,643.22	
	Breezewood, PA	\$1,643.22	
	Canton, PA	\$1,643.22	
	FC of Michigan, MI	\$1,643.22	
	FC of Pennsylvania, PA	\$1,643.22	
	FC of Georgia, GA	\$1,643.22	
	FC of New York, NY	\$1,643.22	
	Lakewood, PA	\$1,643.22	
	FC of Wisconsin, WI	\$1,643.22	
	Mondovi, WI	\$1,643.22	
	FC of the South, AL	\$1,643.22	
	Oswayo, PA	\$1,643.22	
	Seneca Gorham	\$1,643.22	
	FC of the South, FL and AL (study areas OCN 4464,4465)	\$1,643.22	
	Sylvan, NY	\$1,643.22	
	Thorntown, IN	\$1,643.22	
	FC of WI, WI3	\$1,643.22	(C)
	(WI Study area OCN 0964)		
	Channel Mileage Termination, per termination, per month		
	Rochester, NY	\$ 0.00	
	FC of Illinois, IL	\$5,476.80	(C)
	Midland, IL	\$7,833.18	
	Mt. Pulaski, IL	\$1,402.14	
	Lakeside, IL	\$10,074.61	
	Schuler, IL	\$7,503.20	
	Orion, IL	\$4,590.81	(C)
	All Other Companies	\$ 0.00	
	<u>Discontinuance Non-Recurring Charge – Per Circuit</u>		
	Voice Grade 2Wire/4Wire, All Companies	\$975.00	
	<u>Optional Features & Functions – includes Non-Competitive Exchanges</u>		
	<u>Bridging</u>		
	Voice Bridging, per port per month		
	Rochester	ICB	
	All Other Companies	ICB	
	Data Bridging, per port per month		
	Rochester	\$6.00	
	All Other Companies	\$6.00	
	Telemetry and Alarm Bridging		
	Passive Bridging Channel Connections, per channel Connected		
	Rochester	\$15.37	
	All Other Companies	\$15.37	

ACCESS SERVICE

16. Rates and Charges (Cont'd)

16.5 Special Access, Competitive Counties (Cont'd)

Voice Grade Service (Cont'd)

Optional Features & Functions – includes Non-Competitive Exchanges (Cont'd)

Conditioning

C-Type Conditioning, Rochester		
per point of termination, per month		\$1.00
Nonrecurring Charge		\$180.00

C-Type Conditioning, All Other Companies		
per point of termination, per month		\$4.05
Nonrecurring Charge		\$180.00

Sealing Current, per month		
Rochester	\$0.00	
All Other Companies	\$0.00	

Improved Return Loss, Rochester		
for Effective two-wire or four-wire transmission,		
per point of termination, per month		ICB
Nonrecurring Charge		\$280.00

Customer Specified Receive Level, Rochester		
per two wire point of termination, per month		ICB
Nonrecurring Charge		\$170.00

Data Capability, Rochester		
per point of termination, per month	\$1.50	
Nonrecurring Charge	\$225.00	

Data Capability, All Other Companies		
per point of termination, per month	\$1.00	
Nonrecurring Charge	\$225.00	

Telephoto Capability, Rochester		
per point of termination, per month	ICB	
Nonrecurring Charge	\$300.00	

ACCESS SERVICE

16. Rates and Charges (Cont'd)

16.5 Special Access, Competitive Counties (Cont'd)

Voice Grade Service (Cont'd)

Optional Features & Functions – includes Non-Competitive Exchanges (Cont'd)

Channel Interface, Rochester
per point of termination, per month, signaling type:

AL	ICB
DA	\$1.00
DB	\$1.00
DD	ICB
DE	ICB
DS	ICB
DX	\$1.00
DY	ICB
EA	\$1.00
EB	\$1.00
GO	\$1.00
GS	\$1.00
LA	\$1.00
LB	\$1.00
LC	\$1.00
LO	\$1.00
LR	\$1.00
LS	\$1.00
NO	\$1.00
SF	\$1.00
TF	\$1.00

ACCESS SERVICE

16. Rates and Charges (Cont'd)

16.5 Special Access, Competitive Counties (Cont'd)

Voice Grade Service (Cont'd)

Optional Features & Functions – includes Non-Competitive Exchanges (Cont'd)

Channel Interface, Specified Companies

for all signaling types, per point of termination per month

Illinois	\$0.00
Lakeside	\$0.00
Midland	\$0.00
Mt. Pulaski	\$0.00
Prairie	\$0.00
Schuyler	\$0.00

Channel Interface, All Other Companies

per point of termination, per month, signaling type:

AL	ICB
DA	\$0.72
DB	\$0.72
DD	ICB
DE	ICB
DS	ICB
DX	\$0.72
EA	\$0.72
EB	\$0.72
GO	\$0.72
GS	\$0.72
LA	\$0.72
LB	\$0.72
LC	\$0.72
LO	\$0.72
LR	\$0.72
LS	\$0.72
NO	\$0.72
SF	\$0.72
TF	\$0.72

ACCESS SERVICE

16. Rates and Charges (Cont'd)

16.5 Special Access, Competitive Counties (Cont'd)

Voice Grade Service (Cont'd)

Optional Features & Functions – includes Non-Competitive Exchanges (Cont'd)

Rochester Nonrecurring Charges
per Voice Grade package installed, package:

1	ICB
2	\$ 425.00
3	\$ 425.00
4	\$ 425.00
5	\$ 425.00
6	\$ 425.00
7	\$ 425.00
8	\$ 425.00
9	\$ 425.00
10	ICB
11	\$ 425.00

All Other Companies Nonrecurring Charges
per Voice Grade package installed, package:

1	ICB
2	\$ 425.00
3	\$ 425.00
4	\$ 425.00
5	\$ 425.00
6	\$ 425.00
7	\$ 425.00
8	\$ 425.00
9	\$ 425.00
10	ICB
11	\$ 425.00

ACCESS SERVICE

16. Rates and Charges (Cont'd)

16.5 Special Access, Competitive Counties (Cont'd)

Program Audio Service

Channel Termination

rate per termination, per month

Rochester

50-15,000 Hz	\$48.34
200-3,500 Hz	\$37.38
100-5,000 Hz	\$46.00
50-8,000 Hz	\$46.00

All Other Companies

50-15,000 Hz	\$48.00
200-3,500 Hz	\$35.00
100-5,000 Hz	\$46.00
50-8,000 Hz	\$46.00

rate per termination, per day

Rochester

50-15,000 Hz	\$24.50
200-3,500 Hz	\$18.75
100-5,000 Hz	\$23.00
50-8,000 Hz	\$23.00

All Other Companies

50-15,000 Hz	\$21.72
200-3,500 Hz	\$17.50
100-5,000 Hz	\$23.00
50-8,000 Hz	\$23.00

Nonrecurring Charge

Rochester

50-15,000 Hz	\$695.00
200-3,500 Hz	\$695.00
100-5,000 Hz	\$695.00
50-8,000 Hz	\$695.00

All Other Companies

50-15,000 Hz	\$695.00
200-3,500 Hz	\$695.00
100-5,000 Hz	\$695.00
50-8,000 Hz	\$695.00

ACCESS SERVICE

16. Rates and Charges (Cont'd)

16.5 Special Access, Competitive Counties (Cont'd)

Program Audio Service (Cont'd)

Channel Mileage

Channel Mileage Facility, each 5 miles or fraction thereof, per month

Rochester

50-15,000 Hz	\$22.40
200-3,500 Hz	\$22.40
100-5,000 Hz	\$22.40
50-8,000 Hz	\$22.40

All Other Companies

50-15,000 Hz	\$22.40
200-3,500 Hz	\$21.70
100-5,000 Hz	\$22.40
50-8,000 Hz	\$22.40

Channel Mileage Facility, each 5 miles or fraction thereof, per day

Rochester

50-15,000 Hz	\$11.20
200-3,500 Hz	\$11.20
100-5,000 Hz	\$11.20
50-8,000 Hz	\$11.20

All Other Companies

50-15,000 Hz	\$11.20
200-3,500 Hz	\$11.20
100-5,000 Hz	\$11.20
50-8,000 Hz	\$11.20

Channel Mileage Facility, Nonrecurring Charge

Rochester

50-15,000 Hz	\$215.00
200-3,500 Hz	\$215.00
100-5,000 Hz	\$215.00
50-8,000 Hz	\$215.00

All Other Companies

50-15,000 Hz	\$215.00
200-3,500 Hz	\$215.00
100-5,000 Hz	\$215.00
50-8,000 Hz	\$215.00

ACCESS SERVICE

16. Rates and Charges (Cont'd)

16.5 Special Access, Competitive Counties (Cont'd)

Program Audio Service (Cont'd)

Channel Mileage (Cont'd)

Channel Mileage Termination, per termination, per month

Rochester

50-15,000 Hz	\$0.00
200-3,500 Hz	\$0.00
100-5,000 Hz	\$0.00
50-8,000 Hz	\$0.00

All Other Companies

50-15,000 Hz	\$0.00
200-3,500 Hz	\$0.00
100-5,000 Hz	\$0.00
50-8,000 Hz	\$0.00

Channel Mileage Termination, per termination, per day

Rochester

50-15,000 Hz	\$0.00
200-3,500 Hz	\$0.00
100-5,000 Hz	\$0.00
50-8,000 Hz	\$0.00

All Other Companies

50-15,000 Hz	\$0.00
200-3,500 Hz	\$0.00
100-5,000 Hz	\$0.00
50-8,000 Hz	\$0.00

Optional Features & Functions

Bridging, per Distribution port, Rochester

rate per month	ICB
rate per day	ICB
nonrecurring Charge	ICB

Gain Conditioning, per service, Rochester

rate per month	ICB
rate per day	ICB
nonrecurring Charge	\$265.00

Stereo, per service, Rochester

rate per month	ICB
rate per day	ICB
nonrecurring Charge	\$265.00

ACCESS SERVICE

16. Rates and Charges (Cont'd)

16.5 Special Access, Competitive Counties (Cont'd)

Digital Data Service

Channel Termination

Rochester

rate per termination, per month

-Competitive Exchanges – End User

-IC CDL– includes Non-Competitive Exchanges

2.4 Kbps \$6,846.04

4.8 Kbps \$6,846.04

9.6 Kbps \$6,846.04

19.2 Kbps \$8,215.17

56 Kbps \$8,215.17

64 Kbps \$8,215.17

Nonrecurring Charge-

2.4 Kbps \$58,190.44

4.8 Kbps \$58,190.44

9.6 Kbps \$58,190.44

19.2 Kbps \$57,622.48

56 Kbps \$57,622.48

64 Kbps \$57,622.48

Orion – 56 Kbps

rate per termination, per month

Competitive Exchanges – End User & IC CDL \$13,761.97

Nonrecurring Charge \$58,190.44

Illinois – 9.6 Kbps

rate per termination, per month

-Competitive Counties – End User & IC CDL \$12,791.15

Nonrecurring Charge \$58,190.44

Schuyler

rate per termination, per month

-Competitive Counties – End User & IC CDL

- 9.6 Kbps \$20,403.60

56 Kbps \$24,260.79

Nonrecurring Charge

9.6 Kbps & 56 Kbps \$58,190.44

(C)

(C)

ACCESS SERVICE

16.	<u>Rates and Charges (Cont'd)</u>		
16.5	<u>Special Access, Competitive Counties (Cont'd)</u>		
	<u>Digital Data Service (Cont'd)</u>		
	<u>Channel Termination (Cont'd)</u>		
		rate per termination, per month	
		-Competitive Exchanges – End User & IC CDL	
		– includes Non-Competitive Exchanges	(C)
		-All Speeds	
	Midland, IL	\$6,846.04	
	Mt. Pulaski IL	\$6,846.04	
	Lakeside, IL	\$6,846.04	
	Prairie, IL	\$6,846.04	
	AuSable, NY	\$6,846.04	
	Breezewood, PA	\$6,846.04	
	Canton, PA	\$6,846.04	
	FC of Michigan, MI	\$6,846.04	
	FC of Pennsylvania, PA	\$6,846.04	
	FC of Georgia, GA	\$6,846.04	
	FC of New York, NY	\$6,846.04	
	Lakewood, PA	\$6,846.04	
	FC of Wisconsin, WI	\$6,846.04	
	Mondovi, WI	\$6,846.04	
	FC of the South, AL	\$6,846.04	
	Oswayo, PA	\$6,846.04	
	Seneca Gorham	\$6,846.04	
	FC of the South, FL and AL		
	(study areas OCN 4464,4465)	\$6,846.04	
	Sylvan, NY	\$6,846.04	
	Thorntown, IN	\$6,846.04	
	FC of WI, WI3	\$6,846.04	
	(WI Study area OCN 0964)		
	Nonrecurring Charge-		
	Midland, IL		
	2.4 Kbps	\$58,190.44	
	4.8 Kbps	\$58,190.44	
	9.6 Kbps	\$58,190.44	
	19.2 Kbps	\$57,622.48	
	56 Kbps	\$58,190.44	
	64 Kbps	\$57,622.48	
	Mt. Pulaski IL		
	2.4 Kbps	\$58,190.44	
	4.8 Kbps	\$58,190.44	
	9.6 Kbps	\$58,190.44	
	19.2 Kbps	\$57,622.48	
	56 Kbps	\$58,190.44	
	64 Kbps	\$57,622.48	
	Lakeside, IL		
	2.4 Kbps	\$58,190.44	
	4.8 Kbps	\$58,190.44	
	9.6 Kbps	\$58,190.44	
	19.2 Kbps	\$57,622.48	
	56 Kbps	\$58,190.44	
	64 Kbps	\$57,622.48	(C)

ACCESS SERVICE

16.	<u>Rates and Charges (Cont'd)</u>		
16.5	<u>Special Access, Competitive Counties (Cont'd)</u>		
	<u>Digital Data Service (Cont'd)</u>		
	<u>Channel Termination (Cont'd)</u>		
	<u>Nonrecurring Charge (cont'd)</u>		
	Prairie, IL		
	2.4 Kbps	\$58,190.44	(C)
	4.8 Kbps	\$58,190.44	
	9.6 Kbps	\$58,190.44	
	19.2 Kbps	\$57,622.48	
	56 Kbps	\$58,190.44	
	64 Kbps	\$57,622.48	
	AuSable, NY		
	2.4 Kbps	\$58,190.44	
	4.8 Kbps	\$58,190.44	
	9.6 Kbps	\$58,190.44	
	19.2 Kbps	\$57,622.48	
	56 Kbps	\$58,190.44	
	64 Kbps	\$57,622.48	
	Breezewood, PA		
	2.4 Kbps	\$58,190.44	
	4.8 Kbps	\$58,190.44	
	9.6 Kbps	\$58,190.44	
	19.2 Kbps	\$57,622.48	
	56 Kbps	\$58,190.44	
	64 Kbps	\$57,622.48	
	Canton, PA		
	2.4 Kbps	\$58,190.44	
	4.8 Kbps	\$58,190.44	
	9.6 Kbps	\$58,190.44	
	19.2 Kbps	\$57,622.48	
	56 Kbps	\$58,190.44	
	64 Kbps	\$57,622.48	
	FC of Michigan, MI		
	2.4 Kbps	\$58,190.44	
	4.8 Kbps	\$58,190.44	
	9.6 Kbps	\$58,190.44	
	19.2 Kbps	\$57,622.48	
	56 Kbps	\$58,190.44	
	64 Kbps	\$57,622.48	
	FC of Pennsylvania, PA		
	2.4 Kbps	\$58,190.44	
	4.8 Kbps	\$58,190.44	
	9.6 Kbps	\$58,190.44	
	19.2 Kbps	\$57,622.48	
	56 Kbps	\$58,190.44	
	64 Kbps	\$57,622.48	
	FC of Georgia, GA		
	2.4 Kbps	\$58,190.44	
	4.8 Kbps	\$58,190.44	
	9.6 Kbps	\$58,190.44	
	19.2 Kbps	\$57,622.48	
	56 Kbps	\$58,190.44	
	64 Kbps	\$57,622.48	(C)

ACCESS SERVICE

16.	<u>Rates and Charges (Cont'd)</u>		
16.5	<u>Special Access, Competitive Counties (Cont'd)</u>		
	<u>Digital Data Service (Cont'd)</u>		
	<u>Channel Termination (Cont'd)</u>		
	<u>Nonrecurring Charge (cont'd)</u>		
	FC of New York, NY		
	2.4 Kbps	\$58,190.44	(C)
	4.8 Kbps	\$58,190.44	
	9.6 Kbps	\$58,190.44	
	19.2 Kbps	\$57,622.48	
	56 Kbps	\$58,190.44	
	64 Kbps	\$57,622.48	
	Lakewood, PA		
	2.4 Kbps	\$58,190.44	
	4.8 Kbps	\$58,190.44	
	9.6 Kbps	\$58,190.44	
	19.2 Kbps	\$57,622.48	
	56 Kbps	\$58,190.44	
	64 Kbps	\$57,622.48	
	FC of Wisconsin, WI		
	2.4 Kbps	\$58,190.44	
	4.8 Kbps	\$58,190.44	
	9.6 Kbps	\$58,190.44	
	19.2 Kbps	\$57,622.48	
	56 Kbps	\$58,190.44	
	64 Kbps	\$57,622.48	
	Mondovi, WI		
	2.4 Kbps	\$58,190.44	
	4.8 Kbps	\$58,190.44	
	9.6 Kbps	\$58,190.44	
	19.2 Kbps	\$57,622.48	
	56 Kbps	\$58,190.44	
	64 Kbps	\$57,622.48	
	FC of the South, AL		
	2.4 Kbps	\$58,190.44	
	4.8 Kbps	\$58,190.44	
	9.6 Kbps	\$58,190.44	
	19.2 Kbps	\$57,622.48	
	56 Kbps	\$58,190.44	
	64 Kbps	\$57,622.48	
	Oswayo, PA		
	2.4 Kbps	\$58,190.44	
	4.8 Kbps	\$58,190.44	
	9.6 Kbps	\$58,190.44	
	19.2 Kbps	\$57,622.48	
	56 Kbps	\$58,190.44	
	64 Kbps	\$57,622.48	
	Seneca Gorham, NY		
	2.4 Kbps	\$58,190.44	
	4.8 Kbps	\$58,190.44	
	9.6 Kbps	\$58,190.44	
	19.2 Kbps	\$57,622.48	
	56 Kbps	\$58,190.44	
	64 Kbps	\$57,622.48	(C)

ACCESS SERVICE

16. Rates and Charges (Cont'd)

16.5 Special Access, Competitive Counties (Cont'd)

Digital Data Service (Cont'd)

Channel Termination (Cont'd)

Nonrecurring Charge (cont'd)

FC of the South, FL and AL
(study areas OCN 4464,4465)

2.4 Kbps	\$58,190.44
4.8 Kbps	\$58,190.44
9.6 Kbps	\$58,190.44
19.2 Kbps	\$57,622.48
56 Kbps	\$58,190.44
64 Kbps	\$57,622.48

(C)

Sylvan, NY

2.4 Kbps	\$58,190.44
4.8 Kbps	\$58,190.44
9.6 Kbps	\$58,190.44
19.2 Kbps	\$57,622.48
56 Kbps	\$58,190.44
64 Kbps	\$57,622.48

Thorntown, IN

2.4 Kbps	\$58,190.44
4.8 Kbps	\$58,190.44
9.6 Kbps	\$58,190.44
19.2 Kbps	\$57,622.48
56 Kbps	\$58,190.44
64 Kbps	\$57,622.48

FC of WI, WI
(WI Study area OCN 0964)

2.4 Kbps	\$58,190.44
4.8 Kbps	\$58,190.44
9.6 Kbps	\$58,190.44
19.2 Kbps	\$57,622.48
56 Kbps	\$58,190.44
64 Kbps	\$57,622.48

Channel Mileage – includes Non-Competitive Exchanges

Rochester

Channel Mileage Facility, per mile, per month

2.4 kbps	\$2,771.35
4.8 kbps	\$2,771.35
9.6 kbps	\$2,771.35
19.2 kbps	\$2,683.56
56 kbps	\$2,771.35
64 kbps	\$2,683.56

(C)

Channel Mileage Termination, per termination, per month

2.4 kbps	\$0.00
4.8 kbps	\$0.00
9.6 kbps	\$0.00
19.2 kbps	\$0.00
56 kbps	\$0.00
64 kbps	\$0.00

ACCESS SERVICE

16. Rates and Charges (Cont'd)

16.5 Special Access, Competitive Counties (Cont'd)

Digital Data Service (Cont'd)

Channel Mileage – includes Non-Competitive Exchanges (Cont'd)

Orion

Channel Mileage Facility, per mile, per month		
56 Kbps	\$1,013.32	(C)
Channel Mileage Termination, per termination, per month		
56 Kbps	\$13,828.78	

Illinois

Channel Mileage Facility, per mile, per month		
9.6 Kbps	\$2,835.58	
Channel Mileage Termination, per termination, per month		
9.6 Kbps	\$14,833.93	

Schuyler

Channel Mileage Facility, per mile, per month		
9.6 Kbps & 56 Kbps	\$1,990.87	
Channel Mileage Termination, per termination, per month		
9.6 Kbps & 56 kbps	\$8,383.62	

Midland, IL

Channel Mileage Facility, per mile, per month		
2.4 kbps	\$2,771.35	
4.8 kbps	\$2,771.35	
9.6 kbps	\$2,771.35	
19.2 kbps	\$2,683.56	
56 kbps	\$2,771.35	
64 kbps	\$2,683.56	(C)
Channel Mileage Termination, per termination, per month		
2.4 kbps	\$0.00	
4.8 kbps	\$0.00	
9.6 kbps	\$0.00	
19.2 kbps	\$0.00	
56 kbps	\$0.00	
64 kbps	\$0.00	

Mt. Pulaski IL

Channel Mileage Facility, per mile, per month		(C)
2.4 kbps	\$2,771.35	
4.8 kbps	\$2,771.35	
9.6 kbps	\$2,771.35	
19.2 kbps	\$2,683.56	
56 kbps	\$2,771.35	
64 kbps	\$2,683.56	(C)
Channel Mileage Termination, per termination, per month		
2.4 kbps	\$0.00	
4.8 kbps	\$0.00	
9.6 kbps	\$0.00	
19.2 kbps	\$0.00	
56 kbps	\$0.00	
64 kbps	\$0.00	

ACCESS SERVICE

16.	<u>Rates and Charges (Cont'd)</u>		
16.5	<u>Special Access, Competitive Counties (Cont'd)</u>		
	<u>Digital Data Service (Cont'd)</u>		
	<u>Channel Mileage – includes Non-Competitive Exchanges (Cont'd)</u>		
	Lakeside, IL		
	Channel Mileage Facility, per mile, per month		
	2.4 kbps	\$2,771.35	(C)
	4.8 kbps	\$2,771.35	
	9.6 kbps	\$2,771.35	
	19.2 kbps	\$2,683.56	
	56 kbps	\$2,771.35	
	64 kbps	\$2,683.56	(C)
	Channel Mileage Termination, per termination, per month		
	2.4 kbps	\$0.00	
	4.8 kbps	\$0.00	
	9.6 kbps	\$0.00	
	19.2 kbps	\$0.00	
	56 kbps	\$0.00	
	64 kbps	\$0.00	
	Prairie, IL		
	Channel Mileage Facility, per mile, per month		
	2.4 kbps	\$2,771.35	(C)
	4.8 kbps	\$2,771.35	
	9.6 kbps	\$2,771.35	
	19.2 kbps	\$2,683.56	
	56 kbps	\$2,771.35	
	64 kbps	\$2,683.56	(C)
	Channel Mileage Termination, per termination, per month		
	2.4 kbps	\$0.00	
	4.8 kbps	\$0.00	
	9.6 kbps	\$0.00	
	19.2 kbps	\$0.00	
	56 kbps	\$0.00	
	64 kbps	\$0.00	
	AuSable, NY		
	Channel Mileage Facility, per mile, per month		
	2.4 kbps	\$2,771.35	(C)
	4.8 kbps	\$2,771.35	
	9.6 kbps	\$2,771.35	
	19.2 kbps	\$2,683.56	
	56 kbps	\$2,771.35	
	64 kbps	\$2,683.56	(C)
	Channel Mileage Termination, per termination, per month		
	2.4 kbps	\$0.00	
	4.8 kbps	\$0.00	
	9.6 kbps	\$0.00	
	19.2 kbps	\$0.00	
	56 kbps	\$0.00	
	64 kbps	\$0.00	

ACCESS SERVICE

16.	<u>Rates and Charges (Cont'd)</u>		
16.5	<u>Special Access, Competitive Counties (Cont'd)</u>		
	<u>Digital Data Service (Cont'd)</u>		
	<u>Channel Mileage – includes Non-Competitive Exchanges (Cont'd)</u>		
	Breezewood, PA		
	Channel Mileage Facility, per mile, per month		
	2.4 kbps	\$2,771.35	(C)
	4.8 kbps	\$2,771.35	
	9.6 kbps	\$2,771.35	
	19.2 kbps	\$2,683.56	
	56 kbps	\$2,771.35	
	64 kbps	\$2,683.56	(C)
	Channel Mileage Termination, per termination, per month		
	2.4 kbps	\$0.00	
	4.8 kbps	\$0.00	
	9.6 kbps	\$0.00	
	19.2 kbps	\$0.00	
	56 kbps	\$0.00	
	64 kbps	\$0.00	
	Canton, PA		
	Channel Mileage Facility, per mile, per month		
	2.4 kbps	\$2,771.35	(C)
	4.8 kbps	\$2,771.35	
	9.6 kbps	\$2,771.35	
	19.2 kbps	\$2,683.56	
	56 kbps	\$2,771.35	
	64 kbps	\$2,683.56	(C)
	Channel Mileage Termination, per termination, per month		
	2.4 kbps	\$0.00	
	4.8 kbps	\$0.00	
	9.6 kbps	\$0.00	
	19.2 kbps	\$0.00	
	56 kbps	\$0.00	
	64 kbps	\$0.00	
	FC of Michigan, MI		
	Channel Mileage Facility, per mile, per month		
	2.4 kbps	\$2,771.35	(C)
	4.8 kbps	\$2,771.35	
	9.6 kbps	\$2,771.35	
	19.2 kbps	\$2,683.56	
	56 kbps	\$2,771.35	
	64 kbps	\$2,683.56	(C)
	Channel Mileage Termination, per termination, per month		
	2.4 kbps	\$0.00	
	4.8 kbps	\$0.00	
	9.6 kbps	\$0.00	
	19.2 kbps	\$0.00	
	56 kbps	\$0.00	
	64 kbps	\$0.00	

ACCESS SERVICE

16.	<u>Rates and Charges (Cont'd)</u>		
16.5	<u>Special Access, Competitive Counties (Cont'd)</u>		
	<u>Digital Data Service (Cont'd)</u>		
	<u>Channel Mileage – includes Non-Competitive Exchanges (Cont'd)</u>		
	FC of Pennsylvania, PA		
	Channel Mileage Facility, per mile, per month		
	2.4 kbps	\$2,771.35	(C)
	4.8 kbps	\$2,771.35	
	9.6 kbps	\$2,771.35	
	19.2 kbps	\$2,683.56	
	56 kbps	\$2,771.35	
	64 kbps	\$2,683.56	(C)
	Channel Mileage Termination, per termination, per month		
	2.4 kbps	\$0.00	
	4.8 kbps	\$0.00	
	9.6 kbps	\$0.00	
	19.2 kbps	\$0.00	
	56 kbps	\$0.00	
	64 kbps	\$0.00	
	FC of Georgia, GA		
	Channel Mileage Facility, per mile, per month		
	2.4 kbps	\$2,771.35	(C)
	4.8 kbps	\$2,771.35	
	9.6 kbps	\$2,771.35	
	19.2 kbps	\$2,683.56	
	56 kbps	\$2,771.35	
	64 kbps	\$2,683.56	(C)
	Channel Mileage Termination, per termination, per month		
	2.4 kbps	\$0.00	
	4.8 kbps	\$0.00	
	9.6 kbps	\$0.00	
	19.2 kbps	\$0.00	
	56 kbps	\$0.00	
	64 kbps	\$0.00	
	FC of New York, NY		
	Channel Mileage Facility, per mile, per month		
	2.4 kbps	\$2,771.35	(C)
	4.8 kbps	\$2,771.35	
	9.6 kbps	\$2,771.35	
	19.2 kbps	\$2,683.56	
	56 kbps	\$2,771.35	
	64 kbps	\$2,683.56	(C)
	Channel Mileage Termination, per termination, per month		
	2.4 kbps	\$0.00	
	4.8 kbps	\$0.00	
	9.6 kbps	\$0.00	
	19.2 kbps	\$0.00	
	56 kbps	\$0.00	
	64 kbps	\$0.00	

ACCESS SERVICE

16.	<u>Rates and Charges (Cont'd)</u>		
16.5	<u>Special Access, Competitive Counties (Cont'd)</u>		
	<u>Digital Data Service (Cont'd)</u>		
	<u>Channel Mileage – includes Non-Competitive Exchanges (Cont'd)</u>		
	Lakewood, PA		
	Channel Mileage Facility, per mile, per month		
	2.4 kbps	\$2,771.35	(C)
	4.8 kbps	\$2,771.35	
	9.6 kbps	\$2,771.35	
	19.2 kbps	\$2,683.56	
	56 kbps	\$2,771.35	
	64 kbps	\$2,683.56	(C)
	Channel Mileage Termination, per termination, per month		
	2.4 kbps	\$0.00	
	4.8 kbps	\$0.00	
	9.6 kbps	\$0.00	
	19.2 kbps	\$0.00	
	56 kbps	\$0.00	
	64 kbps	\$0.00	
	FC of Wisconsin, WI		
	Channel Mileage Facility, per mile, per month		
	2.4 kbps	\$2,771.35	(C)
	4.8 kbps	\$2,771.35	
	9.6 kbps	\$2,771.35	
	19.2 kbps	\$2,683.56	
	56 kbps	\$2,771.35	
	64 kbps	\$2,683.56	(C)
	Channel Mileage Termination, per termination, per month		
	2.4 kbps	\$0.00	
	4.8 kbps	\$0.00	
	9.6 kbps	\$0.00	
	19.2 kbps	\$0.00	
	56 kbps	\$0.00	
	64 kbps	\$0.00	
	Mondovi, WI		
	Channel Mileage Facility, per mile, per month		
	2.4 kbps	\$2,771.35	(C)
	4.8 kbps	\$2,771.35	
	9.6 kbps	\$2,771.35	
	19.2 kbps	\$2,683.56	
	56 kbps	\$2,771.35	
	64 kbps	\$2,683.56	(C)
	Channel Mileage Termination, per termination, per month		
	2.4 kbps	\$0.00	
	4.8 kbps	\$0.00	
	9.6 kbps	\$0.00	
	19.2 kbps	\$0.00	
	56 kbps	\$0.00	
	64 kbps	\$0.00	

ACCESS SERVICE

16.	<u>Rates and Charges (Cont'd)</u>		
16.5	<u>Special Access, Competitive Counties (Cont'd)</u>		
	<u>Digital Data Service (Cont'd)</u>		
	<u>Channel Mileage – includes Non-Competitive Exchanges (Cont'd)</u>		
	FC of the South, AL		
	Channel Mileage Facility, per mile, per month		
	2.4 kbps	\$2,771.35	(C)
	4.8 kbps	\$2,771.35	
	9.6 kbps	\$2,771.35	
	19.2 kbps	\$2,683.56	
	56 kbps	\$2,771.35	
	64 kbps	\$2,683.56	(C)
	Channel Mileage Termination, per termination, per month		
	2.4 kbps	\$0.00	
	4.8 kbps	\$0.00	
	9.6 kbps	\$0.00	
	19.2 kbps	\$0.00	
	56 kbps	\$0.00	
	64 kbps	\$0.00	
	Oswayo, PA		
	Channel Mileage Facility, per mile, per month		
	2.4 kbps	\$2,771.35	(C)
	4.8 kbps	\$2,771.35	
	9.6 kbps	\$2,771.35	
	19.2 kbps	\$2,683.56	
	56 kbps	\$2,771.35	
	64 kbps	\$2,683.56	(C)
	Channel Mileage Termination, per termination, per month		
	2.4 kbps	\$0.00	
	4.8 kbps	\$0.00	
	9.6 kbps	\$0.00	
	19.2 kbps	\$0.00	
	56 kbps	\$0.00	
	64 kbps	\$0.00	
	Seneca Gorham, NY		
	Channel Mileage Facility, per mile, per month		
	2.4 kbps	\$2,771.35	(C)
	4.8 kbps	\$2,771.35	
	9.6 kbps	\$2,771.35	
	19.2 kbps	\$2,683.56	
	56 kbps	\$2,771.35	
	64 kbps	\$2,683.56	(C)
	Channel Mileage Termination, per termination, per month		
	2.4 kbps	\$0.00	
	4.8 kbps	\$0.00	
	9.6 kbps	\$0.00	
	19.2 kbps	\$0.00	
	56 kbps	\$0.00	
	64 kbps	\$0.00	

ACCESS SERVICE

16.	<u>Rates and Charges (Cont'd)</u>		
16.5	<u>Special Access, Competitive Counties (Cont'd)</u>		
	<u>Digital Data Service (Cont'd)</u>		
	<u>Channel Mileage – includes Non-Competitive Exchanges (Cont'd)</u>		
	FC of the South, FL and AL (study areas OCN 4464,4465)		
	Channel Mileage Facility, per mile, per month		
	2.4 kbps	\$2,771.35	(C)
	4.8 kbps	\$2,771.35	
	9.6 kbps	\$2,771.35	
	19.2 kbps	\$2,683.56	
	56 kbps	\$2,771.35	
	64 kbps	\$2,683.56	(C)
	Channel Mileage Termination, per termination, per month		
	2.4 kbps	\$0.00	
	4.8 kbps	\$0.00	
	9.6 kbps	\$0.00	
	19.2 kbps	\$0.00	
	56 kbps	\$0.00	
	64 kbps	\$0.00	
	Sylvan, NY		
	Channel Mileage Facility, per mile, per month		
	2.4 kbps	\$2,771.35	(C)
	4.8 kbps	\$2,771.35	
	9.6 kbps	\$2,771.35	
	19.2 kbps	\$2,683.56	
	56 kbps	\$2,771.35	
	64 kbps	\$2,683.56	(C)
	Channel Mileage Termination, per termination, per month		
	2.4 kbps	\$0.00	
	4.8 kbps	\$0.00	
	9.6 kbps	\$0.00	
	19.2 kbps	\$0.00	
	56 kbps	\$0.00	
	64 kbps	\$0.00	
	Thorntown, IN		
	Channel Mileage Facility, per mile, per month		
	2.4 kbps	\$2,771.35	(C)
	4.8 kbps	\$2,771.35	
	9.6 kbps	\$2,771.35	
	19.2 kbps	\$2,683.56	
	56 kbps	\$2,771.35	
	64 kbps	\$2,683.56	(C)
	Channel Mileage Termination, per termination, per month		
	2.4 kbps	\$0.00	
	4.8 kbps	\$0.00	
	9.6 kbps	\$0.00	
	19.2 kbps	\$0.00	
	56 kbps	\$0.00	
	64 kbps	\$0.00	

ACCESS SERVICE

16.	<u>Rates and Charges (Cont'd)</u>		
16.5	<u>Special Access, Competitive Counties (Cont'd)</u>		
	<u>Digital Data Service (Cont'd)</u>		
	<u>Channel Mileage – includes Non-Competitive Exchanges (Cont'd)</u>		
	FC of WI, WI		
	(WI Study area OCN 0964)		
	Channel Mileage Facility, per mile, per month		
	2.4 kbps	\$2,771.35	(C)
	4.8 kbps	\$2,771.35	
	9.6 kbps	\$2,771.35	
	19.2 kbps	\$2,683.56	
	56 kbps	\$2,771.35	
	64 kbps	\$2,683.56	(C)
	Channel Mileage Termination, per termination, per month		
	2.4 kbps	\$0.00	
	4.8 kbps	\$0.00	
	9.6 kbps	\$0.00	
	19.2 kbps	\$0.00	
	56 kbps	\$0.00	
	64 kbps	\$0.00	
	<u>Discontinuance Non-Recurring Charge – Per Circuit All States</u>		
	All Speeds, All Companies	\$975.00	

ACCESS SERVICE

16. Rates and Charges (Cont'd)

16.5 Special Access, Competitive Counties (Cont'd)

Digital Data Service (Cont'd)

Optional Features & Functions

Bridging, per port per month	
Rochester	\$14.05
All Other Companies	\$14.05
Secondary Channel, per circuit	
Rochester	
monthly rate	\$17.58
nonrecurring charge	\$30.00
All Other Companies	
monthly rate	\$17.58
nonrecurring charge	\$30.00

ACCESS SERVICE

16. Rates and Charges (Cont'd)

16.5 Special Access, Competitive Counties (Cont'd)
High Capacity Service

Channel Termination

Rochester – Competitive End User &
IC CDL- includes Non-Competitive Exchanges

Rochester DS1 (1.544 Mbps) Month to Month			
rate per termination, per month	\$49,622.36		(C)
nonrecurring charge:			
first channel term on order	\$230,201.64		
add'l channel terms, same order	\$201,816.20		(C)

Rochester DS1 (1.544 Mbps) 18 Month Term Discount Plan # Not Available

Rochester DS1 (1.544 Mbps) 36 Month Term Discount Plan # Not Available

Rochester DS1 (1.544 Mbps) 60 Month Term Discount Plan # Not Available

Lakeside DS1 (1.544 Mbps) Month to Month			
rate per termination, per month			
Competitive End User	\$59,015.22		(C)
IC CDL- includes Non-Competitive Exchanges	\$59,015.22		
nonrecurring charge:			
first channel term on order	\$240,136.10		
add'l channel terms, same order	\$194,720.22		

Mt. Pulaski DS1 (1.544 Mbps) Month to Month			
rate per termination, per month			
Competitive End User Channel Termination	\$59,015.22		
IC CDL- includes Non-Competitive Exchanges	\$59,015.22		
nonrecurring charge:			
first channel term on order	\$240,136.10		
add'l channel terms, same order	\$194,720.22		(C)

Offer is Limited. See Footnote on page 7-61

ACCESS SERVICE

16. Rates and Charges (Cont'd)

16.5 Special Access, Competitive Counties (Cont'd)

High Capacity Service (Cont'd)

Channel Termination (Cont'd)

DS1 (1.544 Mbps) Month to Month- rate per termination, per month:

(C)

FC of Illinois, IL

Competitive End User Channel Termination	\$59,012.35
IC CDL - includes Non-Competitive Exchanges	\$59,012.35
nonrecurring charge:	
first channel term on order	\$240,136.10
add'l channel terms, same order	\$194,720.22

Schuyler, IL

Competitive End User Channel Termination	\$59,012.35
IC CDL - includes Non-Competitive Exchanges	\$59,012.35
nonrecurring charge:	
first channel term on order	\$240,136.10
add'l channel terms, same order	\$194,720.22

Orion, IL

Competitive End User Channel Termination	\$59,012.35
IC CDL - includes Non-Competitive Exchanges	\$59,012.35
nonrecurring charge:	
first channel term on order	\$240,136.10
add'l channel terms, same order	\$194,720.22

Midland, IL

Competitive End User Channel Termination	\$59,012.35
IC CDL - includes Non-Competitive Exchanges	\$59,012.35
nonrecurring charge:	
first channel term on order	\$240,136.10
add'l channel terms, same order	\$194,720.22

Prairie, IL

Competitive End User Channel Termination	\$59,012.35
IC CDL - includes Non-Competitive Exchanges	\$59,012.35
nonrecurring charge:	
first channel term on order	\$240,136.10
add'l channel terms, same order	\$194,720.22

AuSable, NY

Competitive End User Channel Termination	\$59,012.35
IC CDL - includes Non-Competitive Exchanges	\$59,012.35
nonrecurring charge:	
first channel term on order	\$240,136.10
add'l channel terms, same order	\$194,720.22

Breezewood, PA

Competitive End User Channel Termination	\$59,012.35
IC CDL - includes Non-Competitive Exchanges	\$59,012.35
nonrecurring charge:	
first channel term on order	\$240,136.10
add'l channel terms, same order	\$194,720.22

Canton, PA

Competitive End User Channel Termination	\$59,012.35
IC CDL- includes Non-Competitive Exchanges	\$59,012.35
nonrecurring charge:	
first channel term on order	\$240,136.10
add'l channel terms, same order	\$194,720.22

(C)

ACCESS SERVICE

16. Rates and Charges (Cont'd)

16.5 Special Access, Competitive Counties (Cont'd)

High Capacity Service (Cont'd)

Channel Termination (Cont'd)

DS1 (1.544 Mbps) Month to Month- rate per termination, per month (cont'd)

(C)

FC of Michigan, MI

Competitive End User Channel Termination \$59,012.35

IC CDL- includes Non-Competitive Exchanges \$59,012.35

nonrecurring charge:

first channel term on order \$240,136.10

add'l channel terms, same order \$194,720.22

FC of Pennsylvania, PA

Competitive End User Channel Termination \$59,012.35

IC CDL- includes Non-Competitive Exchanges \$59,012.35

nonrecurring charge:

first channel term on order \$240,136.10

add'l channel terms, same order \$194,720.22

FC of Georgia, GA

Competitive End User Channel Termination \$59,012.35

IC CDL- includes Non-Competitive Exchanges \$59,012.35

nonrecurring charge:

first channel term on order \$240,136.10

add'l channel terms, same order \$194,720.22

FC of New York, NY

Competitive End User Channel Termination \$59,012.35

IC CDL- includes Non-Competitive Exchanges \$59,012.35

nonrecurring charge:

first channel term on order \$240,136.10

add'l channel terms, same order \$194,720.22

Lakewood, PA

Competitive End User Channel Termination \$59,012.35

IC CDL- includes Non-Competitive Exchanges \$59,012.35

nonrecurring charge:

first channel term on order \$240,136.10

add'l channel terms, same order \$194,720.22

FC of Wisconsin, WI

Competitive End User Channel Termination \$59,012.35

IC CDL- includes Non-Competitive Exchanges \$59,012.35

nonrecurring charge:

first channel term on order \$240,136.10

add'l channel terms, same order \$194,720.22

Mondovi, WI

Competitive End User Channel Termination \$59,012.35

IC CDL- includes Non-Competitive Exchanges \$59,012.35

nonrecurring charge:

first channel term on order \$240,136.10

add'l channel terms, same order \$194,720.22

FC of the South, AL

Competitive End User Channel Termination \$59,012.35

IC CDL- includes Non-Competitive Exchanges \$59,012.35

nonrecurring charge:

first channel term on order \$240,136.10

add'l channel terms, same order \$194,720.22

(C)

ACCESS SERVICE

16. Rates and Charges (Cont'd)

16.5 Special Access, Competitive Counties (Cont'd)

High Capacity Service (Cont'd) Channel Termination (Cont'd)

DS1 (1.544 Mbps) Month to Month- rate per termination, per month (cont'd)

(C)

Oswayo, PA

Competitive End User Channel Termination	\$59,012.35
IC CDL- includes Non-Competitive Exchanges	\$59,012.35
nonrecurring charge:	
first channel term on order	\$240,136.10
add'l channel terms, same order	\$194,720.22

Seneca Gorham, NY

Competitive End User Channel Termination	\$59,012.35
IC CDL- includes Non-Competitive Exchanges	\$59,012.35
nonrecurring charge:	
first channel term on order	\$240,136.10
add'l channel terms, same order	\$194,720.22

FC of the South, FL and AL
(study areas OCN 4464,4465)

Competitive End User Channel Termination	\$59,012.35
IC CDL- includes Non-Competitive Exchanges	\$59,012.35
nonrecurring charge:	
first channel term on order	\$240,136.10
add'l channel terms, same order	\$194,720.22

Sylvan, NY

Competitive End User Channel Termination	\$59,012.35
IC CDL- includes Non-Competitive Exchanges	\$59,012.35
nonrecurring charge:	
first channel term on order	\$240,136.10
add'l channel terms, same order	\$194,720.22

Thorntown, IN

Competitive End User Channel Termination	\$59,012.35
IC CDL- includes Non-Competitive Exchanges	\$59,012.35
nonrecurring charge:	
first channel term on order	\$240,136.10
add'l channel terms, same order	\$194,720.22

FC of WI, WI
(WI Study area OCN 0964)

Competitive End User Channel Termination	\$59,012.35
IC CDL- includes Non-Competitive Exchanges	\$59,012.35
nonrecurring charge:	
first channel term on order	\$240,136.10
add'l channel terms, same order	\$194,720.22

Rochester DS3 (44.736 Mbps) Month to Month

rate per termination, per month	\$529,860.53
nonrecurring charge:	
first channel term on order	\$462,673.50
add'l channel terms, same order	\$462,673.50

(C)

ACCESS SERVICE

16. Rates and Charges (Cont'd)

16.5 Special Access, Competitive Counties (Cont'd)

High Capacity Service (Cont'd)

Channel Termination (Cont'd)

Rochester DS3 (44.736 Mbps) 18 Month Term Discount Plan #Not Available
 Rochester DS3 (44.736 Mbps) 36 Month Term Discount Plan #Not Available
 Rochester DS3 (44.736 Mbps) 60 Month Term Discount Plan #Not Available

DS3 (44.736 Mbps) Month to Month rate per Termination, per month:

Lakeside, IL

-Competitive End User Channel Termination \$369,996.93
 - IC CDL-includes Non-Competitive Exchanges \$369,996.93
 nonrecurring charge:
 first channel term on order \$462,673.50
 add'l channel terms, same order \$462,673.50

Mt Pulaski, IL

-Competitive End User Channel Termination \$369,996.93
 - IC CDL-includes Non-Competitive Exchanges \$369,996.93
 nonrecurring charge:
 first channel term on order \$462,673.50
 add'l channel terms, same order \$462,673.50

FC of Illinois, IL

-Competitive End User Channel Termination \$369,996.93
 - IC CDL-includes Non-Competitive Exchanges \$369,996.93
 nonrecurring charge:
 first channel term on order \$462,673.50
 add'l channel terms, same order \$462,673.50

Schuyler, IL

-Competitive End User Channel Termination \$369,996.93
 - IC CDL-includes Non-Competitive Exchanges \$369,996.93
 nonrecurring charge:
 first channel term on order \$462,673.50
 add'l channel terms, same order \$462,673.50

Orion, IL

-Competitive End User Channel Termination \$369,996.93
 - IC CDL-includes Non-Competitive Exchanges \$369,996.93
 nonrecurring charge:
 first channel term on order \$462,673.50
 add'l channel terms, same order \$462,673.50

Midland, IL

-Competitive End User Channel Termination \$369,996.93
 - IC CDL-includes Non-Competitive Exchanges \$369,996.93
 nonrecurring charge:
 first channel term on order \$462,673.50
 add'l channel terms, same order \$462,673.50

(C)

(C)

ACCESS SERVICE

16.	<u>Rates and Charges (Cont'd)</u>		
16.5	<u>Special Access, Competitive Counties (Cont'd)</u>		
	<u>High Capacity Service (Cont'd)</u>		
	<u>Channel Termination (Cont'd)</u>		
	DS3 (44.736 Mbps) Month to Month rate per Termination, per month (cont'd):		
	Prairie, IL		
	-Competitive End User Channel Termination	\$369,996.93	(C)
	- IC CDL-includes Non-Competitive Exchanges	\$369,996.93	
	nonrecurring charge:		
	first channel term on order	\$462,673.50	
	add'l channel terms, same order	\$462,673.50	
	AuSable, NY		
	-Competitive End User Channel Termination	\$369,996.93	
	- IC CDL-includes Non-Competitive Exchanges	\$369,996.93	
	nonrecurring charge:		
	first channel term on order	\$462,673.50	
	add'l channel terms, same order	\$462,673.50	
	Breezewood, PA		
	-Competitive End User Channel Termination	\$369,996.93	
	- IC CDL-includes Non-Competitive Exchanges	\$369,996.93	
	nonrecurring charge:		
	first channel term on order	\$462,673.50	
	add'l channel terms, same order	\$462,673.50	
	Canton, PA		
	-Competitive End User Channel Termination	\$369,996.93	
	- IC CDL-includes Non-Competitive Exchanges	\$369,996.93	
	nonrecurring charge:		
	first channel term on order	\$462,673.50	
	add'l channel terms, same order	\$462,673.50	
	FC of Michigan, MI		
	-Competitive End User Channel Termination	\$369,996.93	
	- IC CDL-includes Non-Competitive Exchanges	\$369,996.93	
	nonrecurring charge:		
	first channel term on order	\$462,673.50	
	add'l channel terms, same order	\$462,673.50	
	FC of Pennsylvania, PA		
	-Competitive End User Channel Termination	\$369,996.93	
	- IC CDL-includes Non-Competitive Exchanges	\$369,996.93	
	nonrecurring charge:		
	first channel term on order	\$462,673.50	
	add'l channel terms, same order	\$462,673.50	
	FC of Georgia, GA		
	-Competitive End User Channel Termination	\$369,996.93	
	- IC CDL-includes Non-Competitive Exchanges	\$369,996.93	
	nonrecurring charge:		
	first channel term on order	\$462,673.50	
	add'l channel terms, same order	\$462,673.50	
	FC of New York, NY		
	-Competitive End User Channel Termination	\$369,996.93	
	- IC CDL-includes Non-Competitive Exchanges	\$369,996.93	
	nonrecurring charge:		
	first channel term on order	\$462,673.50	
	add'l channel terms, same order	\$462,673.50	(C)

ACCESS SERVICE

16.	<u>Rates and Charges (Cont'd)</u>	
16.5	<u>Special Access, Competitive Counties (Cont'd)</u>	
	<u>High Capacity Service (Cont'd)</u>	
	<u>Channel Termination (Cont'd)</u>	
	DS3 (44.736 Mbps) Month to Month rate per Termination, per month (cont'd):	
	Lakewood, PA	
	-Competitive End User Channel Termination	\$369,996.93
	- IC CDL-includes Non-Competitive Exchanges	\$369,996.93
	nonrecurring charge:	
	first channel term on order	\$462,673.50
	add'l channel terms, same order	\$462,673.50
	FC of Wisconsin, WI	
	-Competitive End User Channel Termination	\$369,996.93
	- IC CDL-includes Non-Competitive Exchanges	\$369,996.93
	nonrecurring charge:	
	first channel term on order	\$462,673.50
	add'l channel terms, same order	\$462,673.50
	Mondovi, WI	
	-Competitive End User Channel Termination	\$369,996.93
	- IC CDL-includes Non-Competitive Exchanges	\$369,996.93
	nonrecurring charge:	
	first channel term on order	\$462,673.50
	add'l channel terms, same order	\$462,673.50
	FC of the South, AL	
	-Competitive End User Channel Termination	\$369,996.93
	- IC CDL-includes Non-Competitive Exchanges	\$369,996.93
	nonrecurring charge:	
	first channel term on order	\$462,673.50
	add'l channel terms, same order	\$462,673.50
	Oswayo, PA	
	-Competitive End User Channel Termination	\$369,996.93
	- IC CDL-includes Non-Competitive Exchanges	\$369,996.93
	nonrecurring charge:	
	first channel term on order	\$462,673.50
	add'l channel terms, same order	\$462,673.50
	Seneca Gorham, NY	
	-Competitive End User Channel Termination	\$369,996.93
	- IC CDL-includes Non-Competitive Exchanges	\$369,996.93
	nonrecurring charge:	
	first channel term on order	\$462,673.50
	add'l channel terms, same order	\$462,673.50
	FC of the South, FL and AL (study areas OCN 4464,4465)	
	-Competitive End User Channel Termination	\$369,996.93
	- IC CDL-includes Non-Competitive Exchanges	\$369,996.93
	nonrecurring charge:	
	first channel term on order	\$462,673.50
	add'l channel terms, same order	\$462,673.50
	Sylvan, NY	
	-Competitive End User Channel Termination	\$369,996.93
	- IC CDL-includes Non-Competitive Exchanges	\$369,996.93
	nonrecurring charge:	
	first channel term on order	\$462,673.50
	add'l channel terms, same order	\$462,673.50

(C)

(C)

ACCESS SERVICE

16. Rates and Charges (Cont'd)

16.5 Special Access, Competitive Counties (Cont'd)

High Capacity Service (Cont'd)

Channel Termination (Cont'd)

DS3 (44.736 Mbps) Month to Month rate per Termination, per month (cont'd):

Thorntown, IN

-Competitive End User Channel Termination \$369,996.93

- IC CDL-includes Non-Competitive Exchanges \$369,996.93
nonrecurring charge:

first channel term on order \$ 462,673.50

add'l channel terms, same order \$ 462,673.50

FC of WI, WI

(WI Study area OCN 0964)

-Competitive End User Channel Termination \$369,996.93

- IC CDL-includes Non-Competitive Exchanges \$369,996.93
nonrecurring charge:

first channel term on order \$ 462,673.50

add'l channel terms, same order \$ 462,673.50

(C)

(C)

Offer is Limited. See Footnote on page 7-61

ACCESS SERVICE

16. Rates and Charges (Cont'd)

16.5 Special Access, Competitive Counties (Cont'd)

High Capacity Service (Cont'd)

Channel Mileage – includes Non-Competitive Exchanges

Rochester DS1 (1.544 Mbps) Month to Month Channel Mileage Facility, per mile, per month	\$8,138.07	(C)
Channel Mileage Termination, per termination, per month	\$13,176.51	(C)
Rochester DS1 (1.544 Mbps) 18 Month Term Discount Plan <u>#Not Available</u>		
Rochester DS1 (1.544 Mbps) 36 Month Term Discount Plan <u>#Not Available</u>		
Rochester DS1 (1.544 Mbps) 60 Month Term Discount Plan <u>#Not Available</u>		
Lakeside DS1 (1.544 Mbps) Month to Month Channel Mileage Facility, per mile, per month	\$12,489.17	(C)
Channel Mileage Termination, per termination, per month	\$31,223.18	
Mt. Pulaski DS1 (1.544 Mbps) Month to Month Channel Mileage Facility, per mile, per month	\$12,489.17	
Channel Mileage Termination, per termination, per month	\$31,223.18	
DS1 (1.544 Mbps) Month to Month:		
FC of Illinois, IL		
Channel Mileage Facility, per mile, per month	\$10,218.81	
Channel Mileage Termination, per termination, per month	\$14,192.59	
Schuyler, IL		
Channel Mileage Facility, per mile, per month	\$10,218.81	
Channel Mileage Termination, per termination, per month	\$14,192.59	(C)

ACCESS SERVICE

16. Rates and Charges (Cont'd)
 16.5 Special Access, Competitive Counties (Cont'd)
High Capacity Service (Cont'd)

Channel Mileage – includes Non-Competitive Exchanges (cont'd)

DS1 (1.544 Mbps) Month to Month:

Orion, IL

Channel Mileage Facility, per mile, per month	\$10,218.81
Channel Mileage Termination, per termination, per month	\$14,192.59

Midland, IL

Channel Mileage Facility, per mile, per month	\$10,218.81
Channel Mileage Termination, per termination, per month	\$14,192.59

Prairie, IL

Channel Mileage Facility, per mile, per month	\$10,218.81
Channel Mileage Termination, per termination, per month	\$14,192.59

AuSable, NY

Channel Mileage Facility, per mile, per month	\$10,218.81
Channel Mileage Termination, per termination, per month	\$14,192.59

Breezewood, PA

Channel Mileage Facility, per mile, per month	\$10,218.81
Channel Mileage Termination, per termination, per month	\$14,192.59

Canton, PA

Channel Mileage Facility, per mile, per month	\$10,218.81
Channel Mileage Termination, per termination, per month	\$14,192.59

FC of Michigan, MI

Channel Mileage Facility, per mile, per month	\$10,218.81
Channel Mileage Termination, per termination, per month	\$14,192.59

FC of Pennsylvania, PA

Channel Mileage Facility, per mile, per month	\$10,218.81
Channel Mileage Termination, per termination, per month	\$14,192.59

FC of Georgia, GA

Channel Mileage Facility, per mile, per month	\$10,218.81
Channel Mileage Termination, per termination, per month	\$14,192.59

(C)

(C)

ACCESS SERVICE

16. Rates and Charges (Cont'd)

16.5 Special Access, Competitive Counties (Cont'd)
High Capacity Service (Cont'd)

Channel Mileage – includes Non-Competitive Exchanges (cont'd)

DS1 (1.544 Mbps) Month to Month:

FC of New York, NY			(C)
Channel Mileage Facility,			
per mile, per month		\$10,218.81	
Channel Mileage Termination,			
per termination, per month		\$14,192.59	
Lakewood, PA			
Channel Mileage Facility,			
per mile, per month		\$10,218.81	
Channel Mileage Termination,			
per termination, per month		\$14,192.59	
FC of Wisconsin, WI			
Channel Mileage Facility,			
per mile, per month		\$10,218.81	
Channel Mileage Termination,			
per termination, per month		\$14,192.59	
Mondovi, WI			
Channel Mileage Facility,			
per mile, per month		\$10,218.81	
Channel Mileage Termination,			
per termination, per month		\$14,192.59	
FC of the South, AL			
Channel Mileage Facility,			
per mile, per month		\$10,218.81	
Channel Mileage Termination,			
per termination, per month		\$14,192.59	
Oswayo, PA			
Channel Mileage Facility,			
per mile, per month		\$10,218.81	
Channel Mileage Termination,			
per termination, per month		\$14,192.59	
Seneca Gorham, NY			
Channel Mileage Facility,			
per mile, per month		\$10,218.81	
Channel Mileage Termination,			
per termination, per month		\$14,192.59	
FC of the South, FL and AL (study areas OCN 4464,4465)			
Channel Mileage Facility,			
per mile, per month		\$10,218.81	
Channel Mileage Termination,			
per termination, per month		\$14,192.59	
Sylvan, NY			
Channel Mileage Facility,			
per mile, per month		\$10,218.81	
Channel Mileage Termination,			
per termination, per month		\$14,192.59	(C)

ACCESS SERVICE

16. Rates and Charges (Cont'd)

16.5 Special Access, Competitive Counties (Cont'd)

High Capacity Service (Cont'd)

Channel Mileage – includes Non-Competitive Exchanges (cont'd)

DS1 (1.544 Mbps) Month to Month:

Thorntown, IN

Channel Mileage Facility,
per mile, per month \$10,218.81

Channel Mileage Termination,
per termination, per month \$14,192.59

FC of WI, WI

(WI Study area OCN 0964)

Channel Mileage Facility,
per mile, per month \$10,218.81

Channel Mileage Termination,
per termination, per month \$14,192.59

(C)

(C)

Discontinuance Non-Recurring Charge – Per Circuit

DS1 (1.544 Mbps), All Companies \$975.00

Offer is Limited. See Footnote on page 7-61

ACCESS SERVICE

16. Rates and Charges (Cont'd)

16.5 Special Access, Competitive Counties (Cont'd)

High Capacity Service (Cont'd)

Channel Mileage – includes Non-Competitive Exchanges (Cont'd)

Rochester DS3 (44.736 Mbps) Month to Month Channel Mileage Facility, per mile, per month	\$62,446.75	(C)
Channel Mileage Termination, per termination, per month	\$78,058.03	(C)

Rochester DS3 (44.736 Mbps) 18 Month Term Discount Plan #Not Available
 Rochester DS3 (44.736 Mbps) 36 Month Term Discount Plan #Not Available
 Rochester DS3 (44.736 Mbps) 60 Month Term Discount Plan #Not Available

DS3 (44.736 Mbps) Month to Month:

FC of Illinois, IL		(C)
Channel Mileage Facility, per mile, per month	\$62,446.75	
Channel Mileage Termination, per termination, per month	\$78,058.03	
Lakeside , IL		
Channel Mileage Facility, per mile, per month	\$62,446.75	
Channel Mileage Termination, per termination, per month	\$78,058.03	
Mt Pulaski, IL		
Channel Mileage Facility, per mile, per month	\$62,446.75	
Channel Mileage Termination, per termination, per month	\$78,058.03	
Schuyler, IL		
Channel Mileage Facility, per mile, per month	\$62,446.75	
Channel Mileage Termination, per termination, per month	\$78,058.03	(C)

ACCESS SERVICE

16. Rates and Charges (Cont'd)

16.5 Special Access, Competitive Counties (Cont'd)

High Capacity Service (Cont'd)

Channel Mileage – includes Non-Competitive Exchanges (Cont'd)

DS3 (44.736 Mbps) Month to Month (cont'd):

Orion, IL			(C)
Channel Mileage Facility,			
per mile, per month		\$62,446.75	
Channel Mileage Termination,			
per termination, per month		\$78,058.03	
Midland, IL			
Channel Mileage Facility,			
per mile, per month		\$62,446.75	
Channel Mileage Termination,			
per termination, per month		\$78,058.03	
Prairie, IL			
Channel Mileage Facility,			
per mile, per month		\$62,446.75	
Channel Mileage Termination,			
per termination, per month		\$78,058.03	
AuSable, NY			
Channel Mileage Facility,			
per mile, per month		\$62,446.75	
Channel Mileage Termination,			
per termination, per month		\$78,058.03	
Breezewood, PA			
Channel Mileage Facility,			
per mile, per month		\$62,446.75	
Channel Mileage Termination,			
per termination, per month		\$78,058.03	
Canton, PA			
Channel Mileage Facility,			
per mile, per month		\$62,446.75	
Channel Mileage Termination,			
per termination, per month		\$78,058.03	
FC of Michigan, MI			
Channel Mileage Facility,			
per mile, per month		\$62,446.75	
Channel Mileage Termination,			
per termination, per month		\$78,058.03	
FC of Pennsylvania, PA			
Channel Mileage Facility,			
per mile, per month		\$62,446.75	
Channel Mileage Termination,			
per termination, per month		\$78,058.03	
FC of Georgia, GA			
Channel Mileage Facility,			
per mile, per month		\$62,446.75	
Channel Mileage Termination,			
per termination, per month		\$78,058.03	(C)

ACCESS SERVICE

16. Rates and Charges (Cont'd)

16.5 Special Access, Competitive Counties (Cont'd)

High Capacity Service (Cont'd)

Channel Mileage – includes Non-Competitive Exchanges (Cont'd)

DS3 (44.736 Mbps) Month to Month (cont'd):

FC of New York, NY			(C)
Channel Mileage Facility,			
per mile, per month		\$62,446.75	
Channel Mileage Termination,			
per termination, per month		\$78,058.03	
Lakewood, PA			
Channel Mileage Facility,			
per mile, per month		\$62,446.75	
Channel Mileage Termination,			
per termination, per month		\$78,058.03	
FC of Wisconsin, WI			
Channel Mileage Facility,			
per mile, per month		\$62,446.75	
Channel Mileage Termination,			
per termination, per month		\$78,058.03	
Mondovi, WI			
Channel Mileage Facility,			
per mile, per month		\$62,446.75	
Channel Mileage Termination,			
per termination, per month		\$78,058.03	
FC of the South, AL			
Channel Mileage Facility,			
per mile, per month		\$62,446.75	
Channel Mileage Termination,			
per termination, per month		\$78,058.03	
Oswayo, PA			
Channel Mileage Facility,			
per mile, per month		\$62,446.75	
Channel Mileage Termination,			
per termination, per month		\$78,058.03	
Seneca Gorham, NY			
Channel Mileage Facility,			
per mile, per month		\$62,446.75	
Channel Mileage Termination,			
per termination, per month		\$78,058.03	
FC of the South, FL and AL (study areas OCN 4464,4465)			
Channel Mileage Facility,			
per mile, per month		\$62,446.75	
Channel Mileage Termination,			
per termination, per month		\$78,058.03	
Sylvan, NY			
Channel Mileage Facility,			
per mile, per month		\$62,446.75	
Channel Mileage Termination,			
per termination, per month		\$78,058.03	(C)

ACCESS SERVICE

16. Rates and Charges (Cont'd)

16.5 Special Access, Competitive Counties (Cont'd)

High Capacity Service (Cont'd)

Channel Mileage – includes Non-Competitive Exchanges (Cont'd)

DS3 (44.736 Mbps) Month to Month (cont'd):

Thorntown, IN		(C)
Channel Mileage Facility, per mile, per month	\$62,446.75	(C)
Channel Mileage Termination, per termination, per month	\$78,058.03	
FC of WI, WI (WI Study area OCN 0964)		
Channel Mileage Facility, per mile, per month	\$62,446.75	(C)
Channel Mileage Termination, per termination, per month	\$78,058.03	

Discontinuance Non-Recurring Charge – Per Circuit

DS3 (44.736 Mbps), All Companies \$975.00

Offer is Limited. See Footnote on page 7-61

ACCESS SERVICE

16. Rates and Charges (Cont'd)

16.5 Special Access, Competitive Counties (Cont'd)

High Capacity Service (Cont'd)

Optional Features and Functions – includes Non-Competitive Exchanges

Rochester Fiber Loop Diversity , DS1 (1.544 Mbps)	
rate per termination, per month	\$200.00
nonrecurring charge:	
first channel term on order	\$746.00
add'l channel terms, same order	\$646.00

All Other Companies Fiber Loop Diversity, DS1 (1.544 Mbps)	
rate per termination, per month	\$200.00
nonrecurring charge**:	
first channel term on order	\$746.00
add'l channel terms, same order	\$646.00

Multiplexing

DS3 to DS1 Multiplexing, Rochester		
rate per month per arrangement	\$114,958.76	(C)
nonrecurring charge	\$468,350.11	

DS3 to DS1 Multiplexing:

FC of Illinois, IL	
rate per month per arrangement	\$224,240.33
nonrecurring charge	\$468,350.11

Lakeside	
rate per month per arrangement	\$224,240.33
nonrecurring charge	\$468,350.11

Mt Pulaski	
rate per month per arrangement	\$224,240.33
nonrecurring charge	\$468,350.11

Schuyler, IL	
rate per month per arrangement	\$224,240.33
nonrecurring charge	\$468,350.11

Orion, IL	
rate per month per arrangement	\$224,240.33
nonrecurring charge	\$468,350.11

Midland, IL	
rate per month per arrangement	\$224,240.33
nonrecurring charge	\$468,350.11

Prairie, IL	
rate per month per arrangement	\$224,240.33
nonrecurring charge	\$468,350.11

AuSable, NY	
rate per month per arrangement	\$224,240.33
nonrecurring charge	\$468,350.11

Breezewood, PA	
rate per month per arrangement	\$224,240.33
nonrecurring charge	\$468,350.11

Canton, PA		
rate per month per arrangement	\$224,240.33	
nonrecurring charge	\$468,350.11	(C)

ACCESS SERVICE

16. Rates and Charges (Cont'd)

16.5 Special Access, Competitive Counties (Cont'd)

High Capacity Service (Cont'd)

Optional Features and Functions – includes Non-Competitive Exchanges Multiplexing

DS3 to DS1 Multiplexing (cont'd):

FC of Michigan, MI			(C)
	rate per month per arrangement	\$224,240.33	
	nonrecurring charge	\$468,350.11	
FC of Pennsylvania, PA			
	rate per month per arrangement	\$224,240.33	
	nonrecurring charge	\$468,350.11	
FC of Georgia, GA			
	rate per month per arrangement	\$224,240.33	
	nonrecurring charge	\$468,350.11	
FC of New York, NY			
	rate per month per arrangement	\$224,240.33	
	nonrecurring charge	\$468,350.11	
Lakewood, PA			
	rate per month per arrangement	\$224,240.33	
	nonrecurring charge	\$468,350.11	
FC of Wisconsin, WI			
	rate per month per arrangement	\$224,240.33	
	nonrecurring charge	\$468,350.11	
Mondovi, WI			
	rate per month per arrangement	\$224,240.33	
	nonrecurring charge	\$468,350.11	
FC of the South, AL			
	rate per month per arrangement	\$224,240.33	
	nonrecurring charge	\$468,350.11	
Oswayo, PA			
	rate per month per arrangement	\$224,240.33	
	nonrecurring charge	\$468,350.11	
Seneca Gorham, NY			
	rate per month per arrangement	\$224,240.33	
	nonrecurring charge	\$468,350.11	
FC of the South, FL and AL (study areas OCN 4464,4465)			
	rate per month per arrangement	\$224,240.33	
	nonrecurring charge	\$468,350.11	
Sylvan, NY			
	rate per month per arrangement	\$224,240.33	
	nonrecurring charge	\$468,350.11	
Thorntown, IN			
	rate per month per arrangement	\$224,240.33	
	nonrecurring charge	\$468,350.11	
FC of WI, WI (WI Study area OCN 0964)			
	rate per month per arrangement	\$224,240.33	
	nonrecurring charge	\$468,350.11	(C)

ACCESS SERVICE

16. Rates and Charges (Cont'd)

16.5 Special Access, Competitive Counties (Cont'd)

High Capacity Service (Cont'd)

Optional Features and Functions – includes Non-Competitive Exchanges
Multiplexing

DS1 to Voice Multiplexing, Rochester			
rate per month per arrangement	\$101,561.32	(C)	
nonrecurring charge	\$191,882.01		
DS1 to Voice Multiplexing:			
FC of Illinois, IL			
rate per month per arrangement	\$101,561.32		
nonrecurring charge	\$191,882.01		
Lakeside, IL			
rate per month per arrangement	\$101,561.32		
nonrecurring charge	\$191,882.01		
Mt Pulaski, IL			
rate per month per arrangement	\$101,561.32		
nonrecurring charge	\$191,882.01		
Schuyler, IL			
rate per month per arrangement	\$101,561.32		
nonrecurring charge	\$191,882.01		
Orion, IL			
rate per month per arrangement	\$101,561.32		
nonrecurring charge	\$191,882.01		
Midland, IL			
rate per month per arrangement	\$101,561.32		
nonrecurring charge	\$191,882.01		
Prairie, IL			
rate per month per arrangement	\$101,561.32		
nonrecurring charge	\$191,882.01		
AuSable, NY			
rate per month per arrangement	\$101,561.32		
nonrecurring charge	\$191,882.01		
Breezewood, PA			
rate per month per arrangement	\$101,561.32		
nonrecurring charge	\$191,882.01		
Canton, PA			
rate per month per arrangement	\$101,561.32		
nonrecurring charge	\$191,882.01		
FC of Michigan, MI			
rate per month per arrangement	\$101,561.32		
nonrecurring charge	\$191,882.01		
FC of Pennsylvania, PA			
rate per month per arrangement	\$101,561.32		
nonrecurring charge	\$191,882.01		
FC of Georgia, GA			
rate per month per arrangement	\$101,561.32		
nonrecurring charge	\$191,882.01		
FC of New York, NY			
rate per month per arrangement	\$101,561.32		
nonrecurring charge	\$191,882.01	(C)	

ACCESS SERVICE

16. Rates and Charges (Cont'd)

16.5 Special Access, Competitive Counties (Cont'd)

High Capacity Service (Cont'd)

Optional Features and Functions – includes Non-Competitive Exchanges

Multiplexing

DS1 to Voice Multiplexing (cont'd):

Lakewood, PA			(C)
rate per month per arrangement	\$101,561.32		
nonrecurring charge	\$191,882.01		
FC of Wisconsin, WI			
rate per month per arrangement	\$101,561.32		
nonrecurring charge	\$191,882.01		
Mondovi, WI			
rate per month per arrangement	\$101,561.32		
nonrecurring charge	\$191,882.01		
FC of the South, AL			
rate per month per arrangement	\$101,561.32		
nonrecurring charge	\$191,882.01		
Oswayo, PA			
rate per month per arrangement	\$101,561.32		
nonrecurring charge	\$191,882.01		
Seneca Gorham, NY			
rate per month per arrangement	\$101,561.32		
nonrecurring charge	\$191,882.01		
FC of the South, FL and AL (study areas OCN 4464,4465)			
rate per month per arrangement	\$101,561.32		
nonrecurring charge	\$191,882.01		
Sylvan, NY			
rate per month per arrangement	\$101,561.32		
nonrecurring charge	\$191,882.01		
Thorntown, IN			
rate per month per arrangement	\$101,561.32		
nonrecurring charge	\$191,882.01		
FC of WI, WI (WI Study area OCN 0964)			
rate per month per arrangement	\$101,561.32		
nonrecurring charge	\$191,882.01		
DS1 to DS0 Multiplexing, Rochester			
rate per month per arrangement	\$101,561.32		
nonrecurring charge	\$400,226.56		
DS1 to DS0 Multiplexing:			
FC of Illinois, IL			
rate per month per arrangement	\$101,561.32		
nonrecurring charge	\$400,226.56		(C)

ACCESS SERVICE

16. Rates and Charges (Cont'd)

16.5 Special Access, Competitive Counties (Cont'd)

High Capacity Service (Cont'd)

Optional Features and Functions – includes Non-Competitive Exchanges

Multiplexing

DS1 to DS0 Multiplexing (cont'd):

Lakeside			(C)
rate per month per arrangement	\$101,561.32		
nonrecurring charge	\$400,226.56		
Mt Pulaski			
rate per month per arrangement	\$101,561.32		
nonrecurring charge	\$400,226.56		
Schuyler, IL			
rate per month per arrangement	\$101,561.32		
nonrecurring charge	\$400,226.56		
Orion, IL			
rate per month per arrangement	\$101,561.32		
nonrecurring charge	\$400,226.56		
Midland, IL			
rate per month per arrangement	\$101,561.32		
nonrecurring charge	\$400,226.56		
Prairie, IL			
rate per month per arrangement	\$101,561.32		
nonrecurring charge	\$400,226.56		
AuSable, NY			
rate per month per arrangement	\$101,561.32		
nonrecurring charge	\$400,226.56		
Breezewood, PA			
rate per month per arrangement	\$101,561.32		
nonrecurring charge	\$400,226.56		
Canton, PA			
rate per month per arrangement	\$101,561.32		
nonrecurring charge	\$400,226.56		
FC of Michigan, MI			
rate per month per arrangement	\$101,561.32		
nonrecurring charge	\$400,226.56		
FC of Pennsylvania, PA			
rate per month per arrangement	\$101,561.32		
nonrecurring charge	\$400,226.56		
FC of Georgia, GA			
rate per month per arrangement	\$101,561.32		
nonrecurring charge	\$400,226.56		
FC of New York, NY			
rate per month per arrangement	\$101,561.32		
nonrecurring charge	\$400,226.56		
Lakewood, PA			
rate per month per arrangement	\$101,561.32		
nonrecurring charge	\$400,226.56 (C)		

ACCESS SERVICE

16. Rates and Charges (Cont'd)

16.5 Special Access, Competitive Counties (Cont'd)

High Capacity Service (Cont'd)

Optional Features and Functions – includes Non-Competitive Exchanges

Multiplexing

DS1 to DS0 Multiplexing (cont'd):

FC of Wisconsin, WI		(C)
rate per month per arrangement	\$101,561.32	
nonrecurring charge	\$400,226.56	
Mondovi, WI		
rate per month per arrangement	\$101,561.32	
nonrecurring charge	\$400,226.56	
FC of the South, AL		
rate per month per arrangement	\$101,561.32	
nonrecurring charge	\$400,226.56	
Oswayo, PA		
rate per month per arrangement	\$101,561.32	
nonrecurring charge	\$400,226.56	
Seneca Gorham, NY		
rate per month per arrangement	\$101,561.32	
nonrecurring charge	\$400,226.56	
FC of the South, FL and AL (study areas OCN 4464,4465)		
rate per month per arrangement	\$101,561.32	
nonrecurring charge	\$400,226.56	
Sylvan, NY		
rate per month per arrangement	\$101,561.32	
nonrecurring charge	\$400,226.56	
Thorntown, IN		
rate per month per arrangement	\$101,561.32	
nonrecurring charge	\$400,226.56	
FC of WI, WI (WI Study area OCN 0964)		
rate per month per arrangement	\$101,561.32	
nonrecurring charge	\$400,226.56	(C)

** Non-recurring charges apply when the Fiber Loop Diversity option is not installed at the same time as a Channel Termination.

ACCESS SERVICE

16. Rates and Charges (Cont'd)

16.5 Special Access, Competitive Counties (Cont'd)

High Capacity Service (Cont'd)

Optional Features and Functions – includes Non-Competitive Exchanges (Cont'd) (C)

Automatic Protection Switching,** per arrangement, Rochester	
rate per month	ICB
nonrecurring charge	ICB

Signaling Capability, per point of termination, Rochester rate per month for Channel Interface:	
AB	\$3.87
AC	\$3.87
DA	\$3.32
DB	\$3.32
EA	\$3.32
EB	\$3.32
GS	\$3.87
LO	\$3.87
LS	\$3.87
SF	\$3.32
S 15E	\$0.00

Signaling Capability, per point of termination, All Other Companies rate per month for Channel Interface:	
AB	\$3.87
AC	\$3.87
DA	\$3.32
DB	\$3.32
EA	\$3.32
EB	\$3.32
GS	\$3.87
LO	\$3.87
LS	\$3.87
SF	\$3.32
DS-15E	\$6.59

** Requires a duplicate 1.544 Mbps service

ACCESS SERVICE

16. Rates and Charges (Cont'd)

16.5 Special Access, Competitive Counties (Cont'd)

High Capacity Service (Cont'd)

Optional Features and Functions – includes Non-Competitive Exchanges (Cont'd)

Clear Channel Capability, per DS1 circuit

Rochester	rate per month	\$0.00	(C)
	Nonrecurring Charge	\$139,085.90	
FC of Illinois, IL	rate per month	\$0.00	
	Nonrecurring Charge	\$139,085.90	
Lakeside	rate per month	\$0.00	
	Nonrecurring Charge	\$139,085.90	
Mt Pulaski	rate per month	\$0.00	
	Nonrecurring Charge	\$139,085.90	
Schuyler, IL	rate per month	\$0.00	
	Nonrecurring Charge	\$139,085.90	
Orion, IL	rate per month	\$0.00	
	Nonrecurring Charge	\$139,085.90	
Midland, IL	rate per month	\$0.00	
	Nonrecurring Charge	\$139,085.90	
Prairie, IL	rate per month	\$0.00	
	Nonrecurring Charge	\$139,085.90	
AuSable, NY	rate per month	\$0.00	
	Nonrecurring Charge	\$139,085.90	
Breezewood, PA	rate per month	\$0.00	
	Nonrecurring Charge	\$139,085.90	
Canton, PA	rate per month	\$0.00	
	Nonrecurring Charge	\$139,085.90	
FC of Michigan, MI	rate per month	\$0.00	
	Nonrecurring Charge	\$139,085.90	
FC of Pennsylvania, PA	rate per month	\$0.00	
	Nonrecurring Charge	\$139,085.90	
FC of Georgia, GA	rate per month	\$0.00	
	Nonrecurring Charge	\$139,085.90	
FC of New York, NY	rate per month	\$0.00	
	Nonrecurring Charge	\$139,085.90	

(C)

ACCESS SERVICE

16.	<u>Rates and Charges (Cont'd)</u>		
16.5	<u>Special Access, Competitive Counties (Cont'd)</u>		
	<u>High Capacity Service (Cont'd)</u>		
	<u>Optional Features and Functions – includes Non-Competitive Exchanges (Cont'd)</u>		
	<u>Clear Channel Capability, per DS1 circuit (cont'd)</u>		
	Lakewood, PA		(C)
	rate per month	\$0.00	
	Nonrecurring Charge	\$139,085.90	
	FC of Wisconsin, WI		
	rate per month	\$0.00	
	Nonrecurring Charge	\$139,085.90	
	Mondovi, WI		
	rate per month	\$0.00	
	Nonrecurring Charge	\$139,085.90	
	FC of the South, AL		
	rate per month	\$0.00	
	Nonrecurring Charge	\$139,085.90	
	Oswayo, PA		
	rate per month	\$0.00	
	Nonrecurring Charge	\$139,085.90	
	Seneca Gorham, NY		
	rate per month	\$0.00	
	Nonrecurring Charge	\$139,085.90	
	FC of the South, FL and AL (study areas OCN 4464,4465)		
	rate per month	\$0.00	
	Nonrecurring Charge	\$139,085.90	
	Sylvan, NY		
	rate per month	\$0.00	
	Nonrecurring Charge	\$139,085.90	
	Thorntown, IN		
	rate per month	\$0.00	
	Nonrecurring Charge	\$139,085.90	
	FC of WI, WI (WI Study area OCN 0964)		
	rate per month	\$0.00	
	Nonrecurring Charge	\$139,085.90	(C)
	Digital Cross Connect, per arrangement		
	Rochester		
	rate per month	\$0.00	
	Nonrecurring Charge	\$115.00	
	All Other Companies		
	rate per month	\$0.00	
	Nonrecurring Charge	\$115.00	
	<u>Fractional T-1</u>		
	2 x 56/64 Kbps, per arrangement		
	Rochester		
	Port, rate per month	\$55.00	
	Port, Nonrecurring Charge	\$0.00	
	Link, rate per month	\$45.00	
	Link, Nonrecurring Charge	\$0.00	
	All Other Companies		
	Port, rate per month	\$55.00	
	Port, Nonrecurring Charge	\$0.00	
	Link, rate per month	\$45.00	
	Link, Nonrecurring Charge	\$0.00	

ACCESS SERVICE

16. Rates and Charges (Cont'd)

16.5 Special Access, Competitive Counties (Cont'd)

High Capacity Service (Cont'd)

Optional Features and Functions – includes Non-Competitive Exchanges (Cont'd) (C)

Fractional T-1 (Cont'd)

3 x 56/64 Kbps, per arrangement

Rochester

Port, rate per month \$62.00

Port, Nonrecurring Charge \$0.00

Link, rate per month \$45.00

Link, Nonrecurring Charge \$0.00

All Other Companies

Port, rate per month \$62.00

Port, Nonrecurring Charge \$0.00

Link, rate per month \$45.00

Link, Nonrecurring Charge \$0.00

4 x 56/64 Kbps, per arrangement

Rochester

Port, rate per month \$68.00

Port, Nonrecurring Charge \$0.00

Link, rate per month \$45.00

Link, Nonrecurring Charge \$0.00

All Other Companies

Port, rate per month \$68.00

Port, Nonrecurring Charge \$0.00

Link, rate per month \$45.00

Link, Nonrecurring Charge \$0.00

5 x 56/64 Kbps, per arrangement

Rochester

Port, rate per month \$75.00

Port, Nonrecurring Charge \$0.00

Link, rate per month \$45.00

Link, Nonrecurring Charge \$0.00

All Other Companies

Port, rate per month \$75.00

Port, Nonrecurring Charge \$0.00

Link, rate per month \$45.00

Link, Nonrecurring Charge \$0.00

ACCESS SERVICE

16. Rates and Charges (Cont'd)

16.5 Special Access, Competitive Counties (Cont'd)

High Capacity Service (Cont'd)

Optional Features and Functions – includes Non-Competitive Exchanges (Cont'd) (C)

Fractional T-1 (Cont'd)

6 x 56/64 Kbps, per arrangement

Rochester

Port, rate per month \$81.00

Port, Nonrecurring Charge \$0.00

Link, rate per month \$45.00

Link, Nonrecurring Charge \$0.00

All Other Companies

Port, rate per month \$81.00

Port, Nonrecurring Charge \$0.00

Link, rate per month \$45.00

Link, Nonrecurring Charge \$0.00

Enhanced Diversity Management Service (EDMS)

EDMS Level 1, per circuit

Rochester

rate per month \$5.00

Nonrecurring Charge \$20.00

All Other Companies

rate per month \$5.00

Nonrecurring Charge \$20.00

EDMS Level 2, per circuit

Rochester

rate per month \$10.00

Nonrecurring Charge \$41.00

All Other Companies

rate per month \$10.00

Nonrecurring Charge \$41.00

ACCESS SERVICE

16. Rates and Charges (Cont'd)

16.5 Special Access, Competitive Counties (Cont'd)

Digital Interface Options

DIGILINE HC, per DS1 (1.544 Mbps) termination to DACS*		(C)
Rochester		
rate per month	\$170.00	
Nonrecurring Charge	\$75.00	
DIGILINE, per channel termination to DACS*		
Rochester		
Two Wire, per month	\$7.00	
Two Wire Nonrecurring Charge	\$105.00	
Four Wire, per month	\$7.10	
Four Wire Nonrecurring Charge	\$105.00	
DIGILINE Channel Mileage Facility, per DS0 level circuit*		
Rochester		
per mile, per month	\$2.97	
DIGILINE Channel Mileage Termination, per DS0 level circuit*		
Rochester		
per termination, per month	\$0.00	
		(C)

*Effective June 30,2023, orders for new Digiline services are no longer permitted.

ACCESS SERVICE

16. Rates and Charges (Cont'd)

16.5 Special Access, Competitive Counties (Cont'd)

Expanded Interconnection Service

Cross-Connect, per connection, per month

DS1 (1.544 Mbps) connection	\$3.96
DS3 (44.736 Mbps) connection	\$34.74

Central Office Connection Charges

ROCHNYXBDS0 (Stone St.)

License Fees*

Partitioned space, per square foot	
Yearly	\$38.00
Monthly	\$3.17

Conduit space, per cable	
Yearly	\$79.08
Monthly	\$6.59

Cable space, per cable	
Yearly	\$724.68
Monthly	\$60.39

Power Rate

Basic DC Power, w/battery backup per KWH	\$0.20
---	--------

* These fees and rates will be waived if interconnector is currently being assessed such charges under the Telephone Company's intrastate tariff.

ACCESS SERVICE

16. Rates and Charges (Cont'd)

16.5 Special Access, Competitive Counties (Cont'd)

Expanded Interconnection Service (Cont'd)

Central Office Connection Charges (Cont'd)

ROCHNYXADS0 (Plymouth Avenue)

License Fees*

Partitioned space, per square foot	
Yearly	\$33.82
Monthly	\$2.82

Conduit space, per Ln. Ft.	
Yearly	\$23.16
Monthly	\$1.93

Cable space, per Ln. Ft.	
Yearly	\$4.04
Monthly	\$0.337

Power Rate*

Basic DC Power, w/battery backup per KWH	\$0.3420
---	----------

* These fees and rates will be waived if interconnector is currently being assessed such charges under the Telephone Company's intrastate tariff.

ACCESS SERVICE

16. Rates and Charges (Cont'd)

16.5 Special Access, Competitive Counties (Cont'd)

Expanded Interconnection Service (Cont'd)

Central Office Connection Charges (Cont'd)

ROCHNYXCDS0 (Field Street)

License Fees*

Partitioned space, per square foot	
Yearly	\$15.27
Monthly	\$1.27

Conduit space, per Ln. Ft.	
Yearly	\$5.76
Monthly	\$0.48

Cable space, per Ln. Ft.	
Yearly	\$10.21
Monthly	\$0.851

Power Rate*

Basic DC Power, w/battery backup per KWH	\$0.2530
---	----------

* These fees and rates will be waived if interconnector is currently being assessed such charges under the Telephone Company's intrastate tariff.

ACCESS SERVICE

16. Rates and Charges (Cont'd)

16.6 SONET Special Access Service

SONET 55.520 Mbps (OC-3) Month-to-Month and 12 Month plan, Rochester		
Monthly Recurring charges		(C)
Node	\$99,389.36	
DS-1 Port	\$2,319.12	
DS-3 Port	\$16,564.91	
OC-3c Port	\$28,491.42	
Link (per 1/4 airline mile)	\$4,306.80	
Interoffice Transport		
Fixed	\$53,007.78	
per airline mile	\$13,251.84	
Nonrecurring Charges		
Reconfiguration Charge	\$66,259.59	

SONET 55.520 Mbps (OC-3) 24 Month plan, Rochester # Not Available

Effective May 30, 2022, The SONET 24, 36 and 60 Month Plans are no longer permitted. The SONET 24, 36 and/or 60 Month Plans in effect as of May 30, 2022 may continue the existing term but will not be eligible to extend, renew, reenroll in, convert to a new term period, or in any other way continue their existing plan beyond its current expiration. At expiration of the term period, the service will convert to the Month to Month Rate. If at any time an existing customer terminates its SONET 24, 36 and/or 60 Month Plan, the customer may not re-subscribe to the plan.

ACCESS SERVICE

16. Rates and Charges (Cont'd)

16.6 SONET Special Access Service

SONET 55.520 Mbps (OC-3) 36 Month plan, Rochester # Not Available

SONET 55.520 Mbps (OC-3) 60 Month plan, Rochester # Not Available

See Footnote on Page 16-39

ACCESS SERVICE

16. Rates and Charges (Cont'd)

16.6 SONET Special Access Service

SONET 622.080 Mbps (OC-12) Month-to-Month and 12 Month plan, Rochester			
Monthly recurring charges			(C)
Node	\$172,274.81		
DS-1 Port	\$2,319.12		
DS-3 Port	\$13,251.84		
OC-3c Port	\$23,190.81		
OC-12 Port	\$56,983.29		
Link (per 1/4 airline mile)	\$4,306.80		
Interoffice Transport			
Fixed	\$66,259.59		
per airline mile	\$13,251.84		
Nonrecurring Charges			
Reconfiguration Charge	\$66,259.59		(C)

SONET 622.080 Mbps (OC-12) 24 Month plan, Rochester # Not Available

See Footnote on Page 16-39

ACCESS SERVICE

16. Rates and Charges (Cont'd)

16.6 SONET Special Access Service

SONET 622.080 Mbps (OC-12) 36 Month plan, Rochester # Not Available

SONET 622.080 Mbps (OC-12) 60 Month plan, Rochester # Not Available

See Footnote on Page 16-39

ACCESS SERVICE

16. Rates and Charges (Cont'd)

16.6 SONET Special Access Service

SONET 2.488 Gbps (OC-48) Month-to-Month and 12 Month plan, Rochester		
Month to Month recurring charges		(C)
Node	\$318,045.77	
DS-3 Port	\$9,938.83	
OC-3c Port	\$18,221.35	
OC-12 Port	\$56,983.29	
OC-48 or OC-48c Port	\$198,778.37	
Link (per 1/4 airline mile)	\$4,306.80	
Interoffice Transport		
Fixed	\$79,511.65	
per airline mile	\$13,251.84	
Nonrecurring Charges		
Reconfiguration Charge	\$66,259.59	(C)

SONET 2.488 Gbps (OC-48) 24 Month plan, Rochester # Not Available

See Footnote on Page 16-39

ACCESS SERVICE

16. Rates and Charges (Cont'd)

16.6 SONET Special Access Service

SONET 2.488 Gbps (OC-48) 36 Month plan, Rochester #
Not Available

SONET 2.488 Gbps (OC-48) 60 Month plan, Rochester #
Not Available

Maintenance of Service Charge for all SONET services			
- per tech dispatched when no trouble is found in Telephone Company facilities or equipment		\$6,294.63	(C)
Discontinuance Non-Recurring Charge – Per Circuit			
- All SONET services, All Companies, All Terms		\$975.00	

See Footnote on Page 16-39

ACCESS SERVICE

16. Rates and Charges (Cont'd)

16.7 RESERVED FOR FUTURE USE

ACCESS SERVICE

16. Rates and Charges (Cont'd)

16.7 RESERVED FOR FUTURE USE (Cont'd)

ACCESS SERVICE

16. Rates and Charges (Cont'd)

16.8 Miscellaneous Services

Additional Engineering

Basic Time, normally scheduled working hours, per engineer	
First half hour or fraction thereof	\$80.00
Each additional half hour or fraction thereof	\$40.00
Overtime, outside of normally scheduled working hours, per engineer	
First half hour or fraction thereof	\$120.00
Each additional half hour or fraction thereof	\$60.00

Additional Labor

Overtime Installation or Repair

Overtime, outside of normally scheduled working hours, per technician*	
First half hour or fraction thereof	\$40.00
Each additional half hour or fraction thereof	\$30.00

Stand by

Basic Time, normally scheduled working hours, per technician	
First half hour or fraction thereof	None
Each additional half hour or fraction thereof	\$30.00
Overtime, outside of normally scheduled working hours, per technician*	
First half hour or fraction thereof	None
Each additional half hour or fraction thereof	\$45.00
Premium time, outside of normally scheduled work day, per technician*	
First half hour or fraction thereof	None
Each additional half hour or fraction thereof	\$60.00

* A call out of a Telephone Company employee at a time not consecutive with the employee's scheduled work period is subject to a minimum charge of four hours.

ACCESS SERVICE

16. Rates and Charges (Cont'd)

16.8 Miscellaneous Services (Cont'd)

Additional Labor (Cont'd)

Testing and Maintenance with other telephone companies, or Other Labor

Basic Time, normally scheduled working hours, per technician	
First half hour or fraction thereof	\$40.00
Each additional half hour or fraction thereof	\$30.00
Overtime, outside of normally scheduled working hours, per technician*	
First half hour or fraction thereof	\$60.00
Each additional half hour or fraction thereof	\$45.00
Premium time, outside of normally scheduled work day, per technician*	
First half hour or fraction thereof	\$80.00
Each additional half hour or fraction thereof	\$60.00

Maintenance of Service

Basic Time, normally scheduled working hours, per technician	
First half hour or fraction thereof	\$40.00
Each additional half hour or fraction thereof	\$30.00
Overtime, outside of normally scheduled working hours, per technician*	
First half hour or fraction thereof	\$60.00
Each additional half hour or fraction thereof	\$45.00
Premium time, outside of normally scheduled work day, per technician*	
First half hour or fraction thereof	\$80.00
Each additional half hour or fraction thereof	\$60.00

* A call out of a Telephone Company employee at a time not consecutive with the employee's scheduled work period is subject to a minimum charge of four hours.

ACCESS SERVICE

16. Rates and Charges (Cont'd)

16.8 Miscellaneous Services (Cont'd)

Restoration priority

Nonrecurring charge per service arranged ICB

Telecommunications Service Priority (TSP)

TSP per Line or Circuit Assigned, Nonrecurring Charge \$79.00

TSP Record Order Change, Nonrecurring Charge \$10.50

International Blocking Service

Nonrecurring Charge

Rochester \$3.62

Illinois \$20.00

Lakeside \$20.00

Mt. Pulaski \$20.00

Orion \$20.00

Prairie \$20.00

Schuyler-Rushville IL Exchange \$20.00

All Other Companies \$20.00

Billing Name and Address Service

Manual Transaction

Service Establishment Charge

Rochester N/A

All Other Companies \$1.22

Query Charge Per Telephone Number

Rochester N/A

All Other Companies \$0.59

Mechanized Transaction

Service Establishment Charge

Rochester \$113.00

All Other Companies \$36.29

Query Charge Per Telephone Number

Rochester \$0.21

All Other Companies \$0.32

ACCESS SERVICE

16. Rates and Charges (Cont'd)

16.8 Miscellaneous Services (Cont'd)

ACCESS SERVICE

16. Rates and Charges (Cont'd)

16.8 Miscellaneous Services (Cont'd)

ACCESS SERVICE

16. Rates and Charges (Cont'd)

16.8 Miscellaneous Services (Cont'd)

Testing Services, Special Access

Additional Cooperative Acceptance Testing

Basic Time, normally scheduled working hours, per technician	
First half hour or fraction thereof	\$40.00
Each additional half hour or fraction thereof	\$30.00
Overtime, outside of normally scheduled working hours, per technician*	
First half hour or fraction thereof	\$60.00
Each additional half hour or fraction thereof	\$45.00
Premium time, outside of normally scheduled work day, per technician*	
First half hour or fraction thereof	\$80.00
Each additional half hour or fraction thereof	\$60.00

Additional Manual Cooperative and Additional Manual Testing

Basic Time, normally scheduled working hours, per technician	
Each half hour or fraction thereof	\$30.00
Overtime, outside of normally scheduled working hours, per technician*	
Each half hour or fraction thereof	\$45.00
Premium time, outside of normally scheduled work day, per technician*	
Each half hour or fraction thereof	\$60.00

Provision of Access Service Billing Information

Provision of Standard Billing Detail and/or Information in magnetic tape format, in addition to standard paper format, per record, up 20 25 bytes	ICB
Data Transmission to a customer Terminal Location of Billing Detail and/or Information, per record transmitted	ICB
Additional Copies of customer monthly bill or service and features record in standard paper format, in addition to magnetic tape format or microfiche format per page or per microfiche record	ICB

* A call out of a Telephone Company employee at a time not consecutive with the employee's scheduled work period is subject to a minimum charge of four hours.

ACCESS SERVICE

16. Rates and Charges (Cont'd)

16.9 Reserved for Future Use

ACCESS SERVICE

16. Rates and Charges (Cont'd)

16.10 Competitive Counties for Special Access

16.10.1 General

Certain Special Access rates and charges are applied based on whether the End User Channel Termination is served from a "Competitive County." The Special Access End User Channel Termination rates in this Guide apply only to Competitive Counties as listed in Section 10.2 below.

In wire centers within a Competitive County, monthly rates and nonrecurring charges for Special Access rate elements have been detariffed.

16.10.2 Competitive County List

(A) The following wire centers are in Competitive Counties:

State	County	Wire Center
AL	Conecuh	RPTNALXA
AL	Escambia	ATMRALXA
AL	Escambia	HXFRALXA
AL	Escambia	MCCLALXA
AL	Marengo	THMTALXA
FL	Escambia	MOLNFLXA
FL	Escambia	WLHLFLXA
GA	Gordon	FAMTGAXA
GA	Gordon	RNGRGAXA

ACCESS SERVICE

16. Rates and Charges (Cont'd)

16.10 Competitive Counties for Special Access (Cont'd)

16.10.2 Competitive County Lists (Cont'd)

(A) The following wire centers are in Competitive Counties: (Cont'd)

State	County	Wire Center
IL	Bond	PCHNILXE
IL	Cass	ARVLILXC
IL	Henry	ORINILXD
IL	Henry	ORINILXN
IL	Livingston	FLNGILXA
IL	Livingston	GRMTILXA
IL	Livingston	SNMNILXA
IL	McLean	DNVSILXD
IL	McLean	TWNDILXD
IL	Morgan	CNCRILXC
IL	Schuyler	RUVLILXC
IN	Boone	THTWINXA
IN	Tippecanoe	CLHLINXA
MI	Branch	MTGMMIXI
MI	Hillsdale	ALLNMIXI
MI	Hillsdale	CMBAMIXJ
MI	Hillsdale	CMDNMIXI
MI	Hillsdale	FRNTMIXI
MI	Hillsdale	BNHLMIXI
MI	Hillsdale	NADMMIXI
MI	Hillsdale	OSSEMIXI
MI	Hillsdale	PRVLMIXJ
MI	Hillsdale	RNSMMIXJ
MI	Jackson	BRKLMIXI
MI	Jackson	CNCRMIXJ
MI	Jackson	HNVRMIXI
MI	Lenawee	ONSTMIXI

ACCESS SERVICE

16. Rates and Charges (Cont'd)

16.10 Competitive and Non-Competitive Counties for Special Access (Cont'd)

16.10.2 Competitive and Non-Competitive County Lists (Cont'd)

(A) The following wire centers are in Competitive Counties: (Cont'd)

State	County	Wire Center
NY	Clinton	ASFKNYXA
NY	Dutchess	HPJTNYXB
NY	Essex	KSVLNYXA
NY	Essex	WLMGNYXA
NY	Franklin	PLSMNYXA
NY	Genesee	BRGNNYXA
NY	Genesee	LROYNYXA
NY	Genesee	PVLNNYXA
NY	Livingston	AVONNYXA
NY	Livingston	CLDNNYXA
NY	Livingston	DNSVNYXA
NY	Livingston	GENSNYXA
NY	Livingston	HMLCNYXA
NY	Livingston	LCSRNYXA
NY	Livingston	LIVNNYXA
NY	Livingston	MTMRNYXA
NY	Livingston	NUNDNYXA
NY	Livingston	SPWRNYXA
NY	Monroe	BITNNYXA
NY	Monroe	BCPTNYXA
NY	Monroe	CCVLNYXA
NY	Monroe	ERCHNYXA
NY	Monroe	FAPTNYXB
NY	Monroe	HMLNNYXA
NY	Monroe	HNRTNYXA
NY	Monroe	HOFLNYXA
NY	Monroe	PNFDNYXA
NY	Monroe	ROCHNYXB
NY	Monroe	ROCHNYXA
NY	Monroe	ROCHNYXH
NY	Monroe	ROCHNYXD
NY	Monroe	ROCHNYXE

ACCESS SERVICE

16. Rates and Charges (Cont'd)

16.10 Competitive Counties for Special Access (Cont'd)

16.10.2 Competitive County List (Cont'd)

(A) The following wire centers are in Competitive Counties: (Cont'd)

State	County	Wire Center
NY	Monroe	ROCHNYXG
NY	Monroe	ROCHNYXC
NY	Monroe	ROCHNYXF
NY	Monroe	ROCHNYXK
NY	Monroe	ROCHNYXJ
NY	Monroe	ROCJNYEG
NY	Monroe	SCVLNYXA
NY	Monroe	WBSTNYXB
NY	Monroe	WBSTNYXA
NY	Ontario	CANDNYXA
NY	Ontario	FRTNNYXA
NY	Ontario	HLCMNYXA
NY	Ontario	HONYNYXA
NY	Ontario	NPLSNYXA
NY	Ontario	STNLNYXA
NY	Ontario	VCTRNYXA
NY	Orange	CHESNYXA
NY	Orange	GSHNNYXA
NY	Orange	HIMLNYXA
NY	Orange	MYBKNYXA
NY	Orange	MONRNYXA
NY	Orange	MTGMNYXA
NY	Orange	PNBSNYXA
NY	Orange	WLDNNYXC
NY	Orange	WSHVNYXA
NY	Steuben	ATLNNYXA
NY	Steuben	CHCNMYXA
NY	Steuben	WYLDNYXA
NY	Ulster	WLKLNYXA
NY	Wyoming	CSTLNYXA
NY	Wyoming	PRRYNYXA

ACCESS SERVICE

16. Rates and Charges (Cont'd)

16.10 Competitive Counties for Special Access (Cont'd)

16.10.2 Competitive County List (Cont'd)

(A) The following wire centers are in Competitive Counties: (Cont'd)

State	County	Wire Center
NY	Wyoming	WRSWNYXA
NY	Wyoming	WYNGNYXA
NY	Yates	RUVLNYXA
PA	Bradford	CNTNPAXC
PA	Bradford	LERYPAXL
PA	Huntingdon	NWGDPAZN
PA	Lancaster	INTRPAXI
PA	Lancaster	LEOLPAXL
PA	Lancaster	NHLDPAZN
PA	Lancaster	TRHLPAXT
PA	Potter	GENSPAAG
PA	Potter	MLPTPAXM
PA	Potter	SHNGPAXS
WI	Menominee	KSHNWIXA
WI	Outagamie	BRCKWIXA
WI	Shawano	BWLRWIXA
WI	Shawano	CECLWIXA
WI	Shawano	GRHMWIXA
WI	Shawano	NEPTWIXA
WI	Shawano	SHWNWIXA
WI	Shawano	TGTNWIXA
WI	Waupaca	CIVLWIXA
WI	Waupaca	MARNWIXA

DISCLAIMER: THIS DOCUMENTATION IS FOR INFORMATIONAL PURPOSES ONLY AND DOES NOT OBLIGATE FRONTIER TO PROVIDE SERVICES IN THE MANNER DESCRIBED IN THIS DOCUMENT. FRONTIER RESERVES THE RIGHT AS ITS SOLE OPTION TO MODIFY OR REVISE THE INFORMATION IN THIS DOCUMENT AT ANY TIME WITHOUT PRIOR NOTICE. IN NO EVENT SHALL FRONTIER OR ITS AGENTS, EMPLOYEES, DIRECTORS, OFFICERS, REPRESENTATIVES OR SUPPLIERS BE LIABLE UNDER CONTRACT, WARRANTY, TORT (INCLUDING BUT NOT LIMITED TO NEGLIGENCE OF FRONTIER), OR ANY OTHER LEGAL THEORY, FOR ANY DAMAGES ARISING FROM OR RELATING TO THIS DOCUMENT OR ITS CONTENTS, EVEN IF ADVISED OF THE POSSIBILITY OF SUCH DAMAGES.