ACCESS SERVICE

Interstate Service Guide and Pricelist
for Customers of Detariffed Access Services
within the operating territories
listed on the Title Pages

LEGAL NOTICE

The FRONTIER Interstate Service Guide and Pricelist (Guide) applies to the FRONTIER "Detariffed Services" (as defined below) and other telecommunications services that are set forth in this Guide.

Detariffed Services, as described in this document, are interstate special access services for which tariffs were withdrawn pursuant to FCC Report and Order, FCC 17-43, released April 28, 2017.

Beginning upon the effectiveness of the withdrawal of Detariffed Service tariffs, Detariffed Services will be subject to and provided pursuant to the rates, terms and conditions of this Guide, unless a separately executed service agreement between you and Frontier provides otherwise.

Prospective customers wishing to purchase services at the rates, terms and conditions in the Guide may do so by initiating orders through the same processes used to order services from FRONTIER's interstate access tariffs.

Service that is ordered without a separately executed service agreement between you and FRONTIER that applies to that order, will also be subject to the FRONTIER Interstate Access Service Agreement at https://wholesale.frontier.com/dcaas-staticassets/wholesale/SourceFiles/ISG/FTR_Interstate_Access_Service_Agreement_06302023.pdf.

The services described in the Guide may be available through negotiated agreements, which may include rates, terms or conditions more favorable to you than those in the Guide. Prospective customers wishing to purchase Guide services at rates, terms or conditions different from those described in the Guide and the applicable FRONTIER Interstate Access Service Agreement may contact their FRONTIER service representative or go to the FRONTIER website at <https://wholesale.frontier.com/resources/pricing-guides/interstate-service-guide.html>.

FRONTIER reserves the right to change the rates, terms and conditions in the Guide from time to time. Notification of Guide changes will be made available at the FRONTIER website.

DISCLAIMER: THIS DOCUMENTATION IS FOR INFORMATIONAL PURPOSES ONLY AND DOES NOT OBLIGATE FRONTIER TO PROVIDE SERVICES IN THE MANNER DESCRIBED IN THIS DOCUMENT. FRONTIER RESERVES THE RIGHT AS ITS SOLE OPTION TO MODIFY OR REVISE THE INFORMATION IN THIS DOCUMENT AT ANY TIME WITHOUT PRIOR NOTICE. IN NO EVENT SHALL FRONTIER OR ITS AGENTS, EMPLOYEES, DIRECTORS, OFFICERS, REPRESENTATIVES OR SUPPLIERS BE LIABLE UNDER CONTRACT, WARRANTY, TORT (INCLUDING BUT NOT LIMITED TO NEGLIGENCE OF FRONTIER), OR ANY OTHER LEGAL THEORY, FOR ANY DAMAGES ARISING FROM OR RELATING TO THIS DOCUMENT OR ITS CONTENTS, EVEN IF ADVISED OF THE POSSIBILITY OF SUCH DAMAGES.

ACCESS SERVICE

ACCESS SERVICE

Regulations, Rates and Charges
applying to the provision of Access Services
for connection to interstate communications facilities
for customers within the operating territories of the
Frontier Telephone Companies
listed below:

The geographical applications are as indicated following the names of the issuing listed below:

ISSUING CARRIERS

All Regulations, Rates and Charges presented in this Guide are applicable to the following Issuing Carriers. Wire center locations for these Issuing Carriers are located in National Exchange Carrier Association Tariff FCC No. 4.

Frontier California Inc.
For the State of: California (OCN 4420)

Frontier Southwest Incorporated
For the State of: Texas (OCN 2154)

Services herein are provided by means of wire, fiber optics, radio or any other suitable technology or a combination thereof.

ACCESS SERVICE

TABLE OF CONTENTS

	<u>Page No.</u>
ISSUING CARRIERS	Title 1
TABLE OF CONTENTS	1
CONCURRING CARRIERS	11
CONNECTING CARRIERS	11
OTHER PARTICIPATING CARRIERS	11
REGISTERED SERVICE MARKS	11
REGISTERED TRADEMARKS	11
EXPLANATION OF SYMBOLS	11
EXPLANATION OF ABBREVIATIONS	12
REFERENCE TO OTHER TARIFFS	15
REFERENCE TO OTHER PUBLICATIONS	16

ACCESS SERVICE

TABLE OF CONTENTS (Cont'd)

	<u>Page No.</u>
1. <u>APPLICATION OF GUIDE</u>	1-1
2. <u>GENERAL REGULATIONS</u>	2-1
2.1 <u>Undertaking of the Telephone Company</u>	2-1
2.1.1 Scope	2-1
2.1.2 Limitations	2-1
2.1.3 Liability	2-3
2.1.4 Provision of Services	2-4
2.1.5 Installation and Termination of Services	2-4
2.1.6 Maintenance of Services	2-5
2.1.7 Changes, Substitutions and Rearrangements	2-5
2.1.8 Refusal and Discontinuance of Service	2-6
2.1.9 Limitation of Use of Metallic Facilities	2-9
2.1.10 Notification of Service-Affecting Activities	2-9
2.1.11 Coordination with Respect to Network Contingencies	2-9
2.1.12 Provision and Ownership of Telephone Numbers	2-9
2.2 <u>Use</u>	2-10
2.2.1 Interference or Impairment	2-10
2.2.2 Unlawful Use	2-10
2.2.3 Commingling	2-11
2.3 <u>Obligations of the Customer</u>	2-12
2.3.1 Damages	2-12
2.3.2 Ownership of Facilities and Theft	2-12
2.3.3 Equipment Space and Power	2-12
2.3.4 Availability for Testing	2-13
2.3.5 Balance	2-13
2.3.6 Design of Customer Services	2-13
2.3.7 References to the Telephone Company	2-13
2.3.8 Claims and Demands for Damages	2-14
2.3.9 Coordination with Respect to Network Contingencies	2-15
2.3.10 Sectionalization and Trouble Reporting	2-15
2.3.11 RESERVED	2-15

ACCESS SERVICE

TABLE OF CONTENTS (Cont'd)

	<u>Page No.</u>
2. <u>GENERAL REGULATIONS (Cont'd)</u>	
2.4 <u>Payment Arrangements</u>	2-16
2.4.1 Payment of Rates, Charges and Deposits	2-16
2.4.2 Minimum Periods	2-22
2.4.3 Cancellation of an Order for Service	2-22
2.4.4 Reserved for Future Use	2-22
2.4.5 Re-establishment of Service Following Fire, Flood or Other Occurrence	2-23
2.4.6 Title or Ownership Rights	2-23
2.4.7 Access Services Provided by More Than One Telephone Company	2-24
2.5 <u>Connections</u>	2-30
2.5.1 General	2-30
2.5.2 Standard Access Service Connections	2-30
2.6 <u>Definitions</u>	2-31
2.7 <u>Service Level Agreements</u>	2-56
2.7.1 Basic Service Level Agreements (Basic SLAs)	2-56
2.7.1.1 Credit Allowance for Service Interruption	2-57
2.7.1.2 Reserved For Future Use	2-68
2.7.2 Enhanced Service Level Agreements (Enhanced SLAs)	2-69
2.7.2.1 Integrated Optical Service Rider SLAs	2-70
2.7.3 RESERVED	2-74
2.7.4 When a Credit Allowance Does Not Apply	2-75
2.8 <u>Sale or Transfer of an Operating Telephone Company's Assets and/or Stock to an Unaffiliated Third Party</u>	2-79
2.8.1 General	2-79
2.8.2 Undertaking of the Telephone Company Following a Transfer	2-80
2.9 <u>Technology Migration</u>	2-85
2.9.1 Service Under a DS1 Term Payment Plan	2-86
2.9.2 Service Under a DS3 Minimum Service Period	2-86
2.9.3 Service Under a National Discount Plan	2-87
2.9.4 Requirements For a Technology Migration	2-88
2.10 <u>Initial Transfer of Assets from Predecessor Company</u>	2-95
3. <u>RESERVED FOR FUTURE USE</u>	3-1
4. <u>RESERVED FOR FUTURE USE</u>	4-1

(C)

ACCESS SERVICE
TABLE OF CONTENTS (Cont'd)

	<u>Page No.</u>
5. <u>ORDERING SPECIAL ACCESS SERVICE</u>	5-1
5.1 <u>Access Service Request Requirements</u>	5-1
5.1.1 General	5-1
5.1.2 RESERVED	5-2
5.1.3 Special Access Services	5-11
5.1.4 Reserved for Future Use	5-11
5.1.5 Reserved for Future Use	5-12
5.1.6 Provision of Other Services	5-12
5.1.7 Access Order Service Date Intervals	5-13
5.1.8 Selection of Facilities for Access Order	5-13
5.1.9 Shared Use Facilities	5-14
5.1.10 Expanded Interconnection Services (EIS)	5-14
5.1.11 Reserved for Future Use	5-14
5.1.12 Special Construction	5-14
5.2 <u>Access Services Provided by More Than One Telephone Company</u>	5-15
5.3 <u>Access Order Charges</u>	5-17
5.3.1 Access Service Request Modifications	5-17
5.3.2 Cancellation of an Access Service Request	5-22
5.3.3 Minimum Period Charges	5-25
6. <u>RESERVED FOR FUTURE USE</u>	6-1
7. <u>SPECIAL ACCESS SERVICE</u>	7-1
7.1 <u>Provision of Special Access Service</u>	7-1
7.1.1 Circuit Types	7-1
7.1.2 Service Configurations	7-3
7.1.3 Technical Specifications Packages	7-6
7.1.4 Channel Interfaces	7-7
7.1.5 Alternate Use	7-7
7.1.6 Special Facilities Routing	7-7
7.1.7 Design Layout Report	7-8
7.1.8 Acceptance Testing	7-8
7.1.9 Jurisdictional Determination	7-9
7.1.10 Interzone Service	7-10
7.2 <u>Rate Categories, Applications, and Regulations</u>	7-11
7.2.1 Rate Categories	7-11
7.2.2 Minimum Periods	7-37
7.2.3 Application of Daily and Monthly Rates	7-37
7.2.4 Facility Hubs and Multiplexing	7-38
7.2.5 Shared Use Analog and Digital High Capacity Services	7-40
7.2.6 DS3 High Capacity	7-42

ACCESS SERVICE

TABLE OF CONTENTS (Cont'd)

	<u>Page No.</u>
7. <u>SPECIAL ACCESS SERVICE</u> (Cont'd)	
7.3 Reserved for Future Use	7-48
7.4 Reserved for Future Use	7-48
7.5 <u>Voice Grade Service</u>	7-48
7.5.1 Basic Circuit Description	7-48
7.5.2 Technical Specifications Packages	7-49
7.5.3 Channel Interfaces	7-50
7.5.4 Optional Features and Functions	7-50
7.5.5 Rates and Charges	7-56
7.6 <u>Program Audio Service</u>	7-61
7.6.1 Basic Circuit Description	7-61
7.6.2 Technical Specifications Packages	7-61
7.6.3 Channel Interfaces	7-62
7.6.4 Optional Features and Functions	7-62
7.6.5 Rates and Charges	7-63
7.7 <u>TV-1 Analog Service</u>	7-67
7.7.1 Basic Circuit Description	7-67
7.7.2 Technical Specifications Packages	7-67
7.7.3 Channel Interfaces	7-69
7.7.4 Rate Application	7-70
7.7.5 Rates and Charges	7-74
7.8 <u>Reserved for Future Use</u>	7-75
7.9 <u>Reserved for Future Use</u>	7-75
7.10 <u>Digital Data Service</u>	7-76
7.10.1 Basic Circuit Description	7-76
7.10.2 Technical Specifications Packages	7-76
7.10.3 Channel Interfaces	7-77
7.10.4 Optional Features and Functions	7-77
7.10.5 Rates and Charges	7-78

ACCESS SERVICE

TABLE OF CONTENTS (Cont'd)

	<u>Page No.</u>
7. <u>SPECIAL ACCESS SERVICE</u> (Cont'd)	
7.11 <u>High Capacity Service</u>	7-80
7.11.1 Basic Circuit Description	7-80
7.11.2 Technical Specifications Packages	7-80
7.11.3 Channel Interfaces	7-81
7.11.4 Optional Features and Functions	7-81
7.11.5 Rates and Charges	7-86
7.12 <u>RESERVED</u>	7-98
7.13 <u>High Voltage Protection</u>	7-102
7.13.1 Description	7-102
7.13.2 Provisioning	7-102
7.13.3 Claims and Demands for Damage	7-104
7.13.4 Network Outage	7-104
7.13.5 Compliance Statement	7-105
7.13.6 Rate Regulations	7-105
7.13.7 Rates and Charges	7-106
7.14 <u>RESERVED</u>	7-106
7.15 <u>Bonded Digital Link Service</u>	7-107
7.15.1 Basic Circuit Description	7-107
7.15.2 Terms and Conditions	7-108
7.15.3 Rates and Charges	7-109

ACCESS SERVICE

TABLE OF CONTENTS (Cont'd)

	<u>Page No.</u>
8. <u>MISCELLANEOUS SERVICES</u>	8-1
8.1 <u>Additional Engineering</u>	8-1
8.1.1 Charges for Additional Engineering	8-2
8.2 <u>Additional Labor</u>	8-3
8.2.1 Overtime Installation	8-3
8.2.2 Overtime Repair	8-3
8.2.3 Stand By	8-3
8.2.4 Maintenance with other Telephone Companies	8-3
8.2.5 Other Labor	8-3
8.2.6 Charges for Additional Labor	8-4
8.3 <u>Maintenance of Service</u>	8-5
8.4 <u>Additional Testing</u>	8-6
8.5 <u>RESERVED</u>	8-9
8.6 <u>RESERVED</u>	8-9
8.7 <u>RESERVED</u>	8-9
8.8 <u>Telecommunications Service Priority</u>	8-10
8.8.1 General	8-10
8.8.2 Priority Installation	8-10
8.8.3 Priority Restoration	8-11
8.8.4 Rates and Charges	8-12

ACCESS SERVICE

TABLE OF CONTENTS (Cont'd)

	<u>Page No.</u>
9. <u>RESERVED FOR FUTURE USE</u>	9-1
10. <u>RESERVED FOR FUTURE USE</u>	10-1
11. <u>SPECIAL FACILITIES ROUTING OF ACCESS SERVICES</u>	11-1
11.1 <u>Description of Special Facilities Routing of Access Services</u>	11-1
11.1.1 Diversity	11-1
11.1.2 Avoidance	11-1
11.1.3 Cable-Only Facilities	11-1
11.2 <u>Rates and Charges for Special Facilities Routing of Access Service</u>	11-2
11.2.1 Diversity	11-2
11.2.2 Avoidance	11-2
11.2.3 Diversity and Avoidance Combined	11-3
11.2.4 Cable-Only Facilities	11-3

ACCESS SERVICE

TABLE OF CONTENTS (Cont'd)

	<u>Page No.</u>
12. <u>SPECIALIZED SERVICE OR ARRANGEMENTS</u>	12-1
12.1 <u>General</u>	12-1
12.2 <u>Rates and Charges</u>	12-1
13. <u>RESERVED FOR FUTURE USE</u>	13-1
14. <u>RESERVED FOR FUTURE USE</u>	14-1
15. <u>RESERVED FOR FUTURE USE</u>	15-1
16. <u>RESERVED FOR FUTURE USE</u>	16-1
17. <u>RESERVED FOR FUTURE USE</u>	17-1
18. <u>RESERVED FOR FUTURE USE</u>	18-1
19. <u>RESERVED FOR FUTURE USE</u>	19-1
20. <u>OPTICAL NETWORKING</u>	20-1
20(A) <u>General</u>	20-1
20(B) <u>Service Description</u>	20-1
20(C) <u>Conditions</u>	20-2
20(D) <u>Application of Rates and Charges</u>	20-3
20(E) <u>Reserved for Future Use</u>	20-8
20(F) <u>Reserved for Future Use</u>	20-8
20(G) <u>Rate Regulations</u>	20-9
20(H) <u>Off-Net Wire Center</u>	20-12
20(I) <u>Shared Use</u>	20-12
20(J) <u>Reserved for Future Use</u>	20-12
20(K) <u>Reserved for Future Use</u>	20-12
20(L) <u>Rates and Charges</u>	20-13
20.1 <u>Reserved for Future Use</u>	20-22
20.2 <u>Reserved for Future Use</u>	20-22
20.3 <u>Reserved for Future Use</u>	20-22
20.4 <u>Dedicated SONET Entrance Facilities</u>	20-23
21. <u>OPERATING TERRITORIES OF THE FRONTIER TELEPHONE COMPANIES</u>	21-1
21.1 <u>General</u>	21-1
21.2 <u>Operating Territory of Frontier California Inc.</u>	21-2
21.3 <u>Operating Territory of Frontier Southwest Incorporated</u>	21-4
21.4 <u>Competitive and Non-Competitive Counties for Special Access</u>	21-5
21.4.1 <u>General</u>	21.5

ACCESS SERVICE

TABLE OF CONTENTS (Cont'd)

	<u>Page No.</u>
22. <u>DISCOUNT PLANS</u>	22-1
22.1 <u>National Discount Plan</u>	22-1
22.1.1 General	22-1
22.1.2 Subscription	22-11
22.1.3 Qualifying Services	22-13
22.1.4 Commitment Levels and Discount Tiers	22-17
22.1.5 Application of Discount	22-26
22.1.6 Special Access DS3 Service Channel Mileage Rates	22-38
22.1.7 Annual True-Up	22-39
22.1.8 Minimum Period	22-68
22.1.9 Changes to Basic Service and/or Base Rates	22-68
22.1.10 Sale of a Telephone Company Operating Territory	22-69
22.1.11 Addition of an ACNA(s) to an Existing NDP	22-71
22.1.12 Removal of an ACNA(s) as a Result of a Customer Sale	22-85
22.1.13 Termination Liability	22-88
22.1.14 Renewal and Termination of NDP	22-90
23. <u>SERVICE COMPONENTS</u>	23-1
23.1 <u>Integrated Optical Service Riders</u>	23-1
23.1.1 General	23-1
23.1.2 Deployment and Availability	23-1
23.1.3 Connection to Other Services	23-2
23.1.4 Responsibility of the Customer	23-2
23.1.5 Conversions	23-3
23.1.6 Application of Rates	23-3
23.1.7 Term Plans	23-3
23.1.8 Expiration of Commitment Period	23-4
23.1.9 Termination Liability	23-5
23.1.10 Minimum Period	23-5
23.1.11 Rates and Charges	23-6
23.2 <u>Point To Point SONET Service Facilities</u>	23-7
23.2.1 General	23-7
23.2.2 Deployment and Availability	23-7
23.2.3 Connection to Other Services	23-7
23.2.4 Application of Rates	23-8
23.2.5 Term Plans	23-8
23.2.6 Minimum Period	23-8

ACCESS SERVICE

CONCURRING CARRIERS

NO CONCURRING CARRIERS

CONNECTING CARRIERS

NO CONNECTING CARRIERS

OTHER PARTICIPATING CARRIERS

NO OTHER PARTICIPATING CARRIERS

REGISTERED SERVICE MARKS

NONE

REGISTERED TRADEMARKS

NONE

EXPLANATION OF SYMBOLS

- (C) - To signify changed regulation
- (D) - To signify discontinued rate or regulation
- (I) - To signify increase
- (M) - To signify matter relocated without change
- (N) - To signify new rate or regulation
- (R) - To signify reduction
- (S) - To signify reissued matter
- (T) - To signify a change in text but no change in rate or regulation
- (Z) - To signify a correction

ACCESS SERVICE

EXPLANATION OF ABBREVIATIONS

ac	- Alternating current
ACNA	- Access Customer Name Abbreviation
AML	- Actual Measured Loss
ANI	- Automatic Number Identification
AP	- Program Audio
ARC	- Access Recovery Charge
ASR	- Access Service Request
AT&T	- American Telephone and Telegraph Company
ATM	- Asynchronous Transfer Mode (ATM) Network Service
BAN	- Billing Account Number
BD	- Business Day
BHMC	- Busy Hour Minutes of Capacity
BSA	- Basic Serving Arrangement
BSE	- Basic Service Element
CAC	- Carrier Access Code
CAROT	- Centralized Automatic Reporting on Trunks
CCS7	- Common Channel Signaling System 7
CI	- Changes Interface
CIC	- Carrier Identification Code
CLO	- Control Link Oscillator
CNM	- Customer Network Management
CO	- Central Office
COCTX	- Central Office Centrex
Cont'd	- Continued
CPE	- Customer Provided Equipment
CSM	- Customer Service Management
Ctx	- Centrex
dB	- decibel
dBrnC	- Decibel Reference Noise C-Message Weighting
dBrnC0	- Decibel Reference Noise C-Message Weighted 0
dBv	- Decibel(s) Relative to 1 Volt (Reference)
dBvl	- Decibel(s) Relating to 1 Volt (Reference)
dc	- direct current
DSAL	- Dedicated Switched Access Line
DSAT	- Dedicated Switched Access Transport
DTM	- Direct TLI Monitoring Optional Feature
DWDM	- Dense Wave Division Multiplexing
EDD	- Envelope Delay Distortion
ELEPL	- Equal Level Echo Path Loss
EML	- Expected Measured Loss
EPL	- Echo Path Loss
ERL	- Echo Return Loss
ESCON	- Enterprise Systems Connection
ESS	- Electronic Switching System
ESSX	- Electronic Switching System Exchange

ACCESS SERVICE

EXPLANATION OF ABBREVIATIONS (Cont'd)

F	- frequency
FICON	- Fiber Connection
FID	- Field Identifier
FCC	- Federal Communications Commission
FNPA	- Foreign Numbering Plan Area
FX	- Foreign Exchange
HC	- High Capacity
Hz	- Hertz
IC	- Interexchange Carrier
ICB	- Individual Case Basis
ICL	- Inserted Connection Loss
ISC	- InterSystem Channel
Kbps	- Kilobits per second
KHz	- Kilohertz
LATA	- Local Access and Transport Area
Ma	- Milliampere
Mbps	- Megabits per second
MF	- Multifrequency
MHz	- Megahertz
MMUC	- Minimum Monthly Usage Charge
MRC	- Monthly Recurring Charge
MTS	- Message Telecommunications Service(s)
NDP	- National Discount Plan
NPA	- Numbering Plan Area
NG-ADM	- Next Generation – Add/Drop Multiplexing
NMM	- Network Management Methods
NRC	- Nonrecurring Charge
NTS	- Non-Traffic Sensitive
NXX	- Three-Digit Central Office Code
OCn	- Optical Carrier Rate
OTPL	- Zero Transmission Level Point
PBX	- Private Branch Exchange
PCM	- Pulse Code Modulation
PLP	- Private Line Ringdown
POT	- Point of Terminations
Rms	- root-mean-square
RPON	- Related Purchase Order Number
RSM	- Remote Switching Modules
RSS	- Remote Switching Systems

ACCESS SERVICE

EXPLANATION OF ABBREVIATIONS (Cont'd)

SASG	- Special Access Service Guarantee
SCP	- Service Control Point
SLA	- Service Level Agreement
SONET	- Synchronous Optical Network
SPNP	- Service Provider Number Portability
SRL	- Singing Return Loss
SS7	- Signaling System 7
SSN	- Switched Service Network
SSP	- Service Switching Point
STP	- Signaling Transfer Point
STS1-N	- Synchronous Transport Signal 1 Rate
SWC	- Serving Wire Center
TES	- Telephone Exchange Service(s)
TLP	- Transmission Level Point
TSP	- Telecommunications Service Priority
TSPS	- Traffic Service Position System
TV	- Television
USOC	- Uniform Service Order Code
VG	- Voice Grade
V & H	- Vertical & Horizontal
WATS	- Wide Area Telecommunications Service(s)

ACCESS SERVICE

REFERENCE TO OTHER TARIFFS

Whenever reference is made in this Guide to other guides or tariffs, the reference is to the guides or tariffs in force as of the effective date of this Guide, and to amendments thereto and successive issues thereof.

The following tariff is referenced in this Guide and may be obtained from the National Exchange Carrier Association, 80 South Jefferson Road, Whippany, NJ 07981-1009, 800-228-8597, or in electronic format on the internet at www.neca.org.

National Exchange Carrier Association, Inc. (NECA)
Tariff F.C.C. No. 4

ACCESS SERVICE

REFERENCE TO OTHER PUBLICATIONS

The following technical publications are referenced in this Guide and may be obtained from Telcordia Technologies, Customer Service, One Telcordia Drive, RRC 1B-180, Piscataway, NJ 08854-4156, (866)672-6997, or on the Internet at www.telcordia.com.

Compatibility Bulletin 106, Issue 2

Issued: January 1998

Technical Reference:

GR-54-CORE, Issue 1

Issued: December 1995

GR-63-CORE, Issue 3

Issued: March 2006

GR-253-CORE, Issue 4

Issued: December 2005

GR-320-CORE, Issue 1

Issued: August 2003

GR-334-CORE, Issue 1

Issued: July 1994

GR-337-CORE, Issue 1

Issued: December 1995

GR-338-CORE, Issue 1

Issued: December 1995

GR-342-CORE, Issue 1

Issued: December 1995

GR-487-CORE, Issue 3

Issued: April 2009

GR-499-CORE, Issue 3

Issued: September 2004

GR-905-CORE, Issue 11

Issued: December 2008

GR-1089-CORE, Issue 4

Issued: June 2006

GR-1312-CORE, Issue 3

Issued: April 1999

GR-1374-CORE, Issue 1

Issued: December 1994

GR-1400-CORE, Issue 3

Issued: July 2006

GR-1YOD-CORE, Issue 1

Issued: January 1998

GR-2918-CORE, Issue 6

Issued: January 2003

GR-2979-CORE, Issue 5

Issued: March 2005

PUB 41004

Issued: October 1973

PUB 62310

Issued: September 1983

SR-3580, Issue 3

Issued: June 2007

ST-TEC-000053, Issue 1

Issued: August 1989

Telecommunications Transmission Engineering Volume
3 - Networks and Services (Chapters 6 and 7)

TR-NPL-000336, Issue 1

Issued: October 1987

TR-NPL-000339

Issued: October 1987

TR-NPL-000340

Issued: October 1986

TR-NWT-000335, Issue 3

Issued: May 1993

TR-NWT-000341, Issue 2

Issued: February 1993

ACCESS SERVICE

REFERENCE TO OTHER PUBLICATIONS (Cont'd)

The following technical publication is referenced in this Guide and may be obtained from Telcordia Routing Administration, 8 Corporate Place PYA 3N-141, Piscataway, NJ 08854-4156, 1(866) 672-4156.

Technical Reference:

The Local Exchange Routing Guide (LERG), Issued: April, 2007, and as issued from time to time

The following publications are referenced in this Guide and may be obtained from the Government Printing Office, Superintendent of Documents, Document Control Branch, 941 N. Capitol Street, N.E., Washington, DC 20401.

Telecommunications Service Priority (TSP) System for National Security Emergency Preparedness (NSEP) Service Vendor Handbook, National Communications Systems (NCS) H 3-1-2
Issued: December 2000

Telecommunications Service Priority (TSP) System for National Security Emergency Preparedness (NSEP) Service User Manual, National Communications System (NCS) M 3-1-1
Issued: May 2000

The following technical publication is referenced in this Guide and may be obtained from the National Exchange Carrier Association, Inc., 80 S. Jefferson Road, Whippany, NJ 07981-1009 or on the Internet at www.neca.org.

PUB AS No. 1, Issue II
Issued: May 1984

The following publications are referenced in this Guide and may be obtained from the International Telecommunications Union (ITU), Place des Nations, CH-1211, Geneva 20, Switzerland or on the internet at www.itu.int.net.

ITU-T G.692 Issued: October 1998, Amendment 1 January 2005
ITU-T G.959.1 Issued: December 2003

ACCESS SERVICE

REFERENCE TO OTHER PUBLICATIONS (Cont'd)

The following publications are referenced in this Guide and may be obtained from Alliance for Telecommunications Industry Solutions (ATIS), 1200 G Street, NW, Suite 500, Washington, DC 20005 or on the Internet at www.atis.org.

Multiple Exchange Carrier Access Billing Guidelines (MECAB)
ATIS/OBF-MECAB 009, Issue 9 Issued: January 2007

Multiple Exchange Carrier Ordering and Design Guidelines (MECOD)
ATIS-0404120-0007, Issue 7 Issued: April 2009

The following publications are referenced in this Guide and may be obtained from IBM North America, 590 Madison Avenue, New York, NY 10022; 1-800-426-4968 or on the Internet at www.ibm.com/us. Note: ESCON® is a registered trademark of the International Business Machines (IBM) Corporation.

Enterprise Systems Architecture/390 ESCON I/O Interface, Physical Layer (Seventh Edition)

SA23-0394-06 Issued: July 2008

Coupling Facility Channel Physical Layer (Sixth Edition)

SA23-0395-05 Issued: July 2008

Planning Fiber Optic Channel Links (Twelfth Edition)

GA23-0367-12 Issued: July 2009

OS/390 Parallel Sysplex Configuration Volume 2: Cookbook

SG24-5638-00 Issued: August 2000

S/390 Time Management and IBM 9037 Sysplex Timer

SG24-2070-00 Issued: May 1999

The following publication is referenced in this Guide and may be obtained from the Society of Motion Picture and Television Engineers (SMPTE), 3 Barker Avenue, 5th Floor, White Plains, NY 10601, (914)761-1100, or on the Internet at www.smpete.org.

SMPTE 0259M-2008 Issued: 2008

ACCESS SERVICE

REFERENCE TO OTHER PUBLICATIONS (Cont'd)

The following publications are referenced in this Guide and may be obtained from the American National Standards Institute (ANSI), 25 West 43rd Street, 4th Floor, New York, New York 10036, or on the Internet at www.ansi.org.

ANSI T1.102-1993 (R2005)	Issued: 2005
ANSI T1.102.01-1996 (R2001)	Issued: 2001
ANSI T1.105.01-2000 (R2005)	Issued: 2005
ANSI INCITS 148-1988 (R2004)	Issued: 2004
ANSI INCITS 166-1989 (R2005)	Issued: 2005
ANSI INCITS 296-1997 (R2007)	Issued: 2007
ANSI INCITS 303-1998 (R2003)	Issued: 2003

The following publications are referenced in this Guide and may be obtained from Institute of Electrical and Electronics Engineers, Inc., IEEE Standards Association, 445 Hoes Lane, P.O. Box 1331, Piscataway, NJ 08855-1331, or in electronic format on the Internet at www.ieee.org.

IEEE 802.3-2005/Cor2/D2.0-2007	Issued: 2007
IEEE 802.3u-1995	Issued: 1995
IEEE 802.3z-1998	Issued: 1998
IEEE 802.3ae-2002	Issued: 2002

The following publication is referenced in this Guide and may be obtained from the COMM 2000, 1414 Brook Drive, Downers Grove, IL 60515 (888)-UL33503 or on the Internet at www.comm-2000.com.

UL 94, Edition 5 Issued: October 1996

The following publications are referenced in this Guide and may be obtained from the Internet Engineering Task Force (IETF) at IETF Secretariat, c/o Association Management Solutions, LLC (AMS), 48377 Fremont Blvd., Suite 117, Fremont, California 94538, or on the Internet at www.ietf.org.

STD 0001: Internet Official Protocol Standards, J Postel, Editor, Issued: May 2008.

RFC 2138, Remote Authentication Dial-In User Service (RADIUS); C Rigney, A. Rubens, W. Simpson, S. Willens, Issued: April 1997.

The following publication is referenced in this Guide and may be obtained from Frontier Carrier Services, 1919 McKinney Ave, Dallas, TX 75201. (T)

Technical Memorandum for Incidental InterLATA Call Management Signaling Service associated with the Verizon FCC Short Term Notice of Network Change dated March 2007. Issued: March 2007

ACCESS SERVICE

2. General Regulations

2.1 Undertaking of the Telephone Company

2.1.1 Scope

- (A) The Telephone Company does not undertake to transmit messages under this Guide.
- (B) The Telephone Company shall be responsible only for the installation, operation, and maintenance of the services it provides.
- (C) The Telephone Company will, for maintenance purposes, test its services only to the extent necessary to detect and/or clear troubles.
- (D) Services are provided 24 hours daily, seven days per week, except as set forth in other applicable sections of this Guide.
- (E) The Telephone Company does not warrant that its facilities and services meet standards other than those set forth in this Guide.

2.1.2 Limitations

- (A) The customer may not assign or transfer the use of services provided under this Guide; however, where there is no interruption of use or relocation of the services, such assignment or transfer may be made to:
 - (1) another customer, whether an individual, partnership, association or corporation, provided the assignee or transferee assumes all outstanding indebtedness for such services, and the unexpired portion of the minimum period and the termination liability applicable to such services, if any; or
 - (2) a court-appointed receiver, trustee or other person acting pursuant to law in bankruptcy, receivership, reorganization, insolvency, liquidation or other similar proceedings, provided the assignee or transferee assumes the unexpired portion of the minimum period and the termination liability applicable to such services, if any.

ACCESS SERVICE

2. General Regulations (Cont'd)

2.1 Undertaking of the Telephone Company (Cont'd)

2.1.2 Limitations (Cont'd)

(A) (Cont'd)

In all cases of assignment or transfer, the written acknowledgment of the Telephone Company is required prior to such assignment or transfer which acknowledgment shall be made within 15 days from the receipt of notification. All rates, regulations and conditions contained in this Guide shall apply to such assignee or transferee.

The assignment or transfer of services does not relieve or discharge the assignor or transferor from remaining jointly or severally liable with the assignee or transferee for any obligation existing at the time of the assignment or transfer.

(B) The regulations for the restoration and installation of Telecommunications Service Priority (TSP) System services shall be in accordance with Part 64, Subpart D, Appendix A, of the Federal Communications Commission's Rules and Regulations and Section 8.8 following.

(C) Subject to compliance with the rules mentioned in (B) preceding, the services offered herein will be provided to customers on a first-come, first-served basis, except as outlined in (D) following.

ACCESS SERVICE

2. General Regulations (Cont'd)

2.1 Undertaking of the Telephone Company (Cont'd)

2.1.3 Liability

- (A) The Telephone Company's liability, if any, for its willful misconduct is not limited by this Guide. With respect to any other claim or suit, by a customer or by any others, for damages associated with the installation, provision, preemption, termination, maintenance, repair or restoration, of service, and subject to the provisions of (B) through (H) following, the Telephone Company's liability if any, shall not exceed an amount equal to the proportionate charge for the service for the period during which the service was affected. This liability for damages shall be in addition to any amounts that may otherwise be due the customer under this Guide as a Credit Allowance for a Service Interruption.
- (B) The Telephone Company shall not be liable for any act or omission of any other carrier or customer providing a portion of a service, nor shall the Telephone Company for its own act or omission hold liable any other carrier or customer providing a portion of a service.
- (C) The Telephone Company is not liable for damages to the customer premises resulting from the furnishing of a service, including the installation and removal of equipment and associated wiring, unless the damage is caused by the Telephone Company's negligence.
- (D) The Telephone Company shall be indemnified, defended and held harmless by the customer against any claim, loss or damage arising from the customer's use of services offered under this Guide, involving:
- (1) Claims for libel, slander, invasion of privacy, or infringement of copyright arising from the customer's own communications.
 - (2) Claims for patent infringement arising from the customer's acts combining or using the service furnished by the Telephone Company in connection with facilities or equipment furnished by the customer or;
 - (3) All other claims arising out of any act or omission of the customer in the course of using services provided pursuant to this Guide.

ACCESS SERVICE

2. General Regulations (Cont'd)

2.1 Undertaking of the Telephone Company (Cont'd)

2.1.3 Liability (Cont'd)

(E) The Telephone Company does not guarantee or make any warranty with respect to its services when used in an explosive atmosphere. The Telephone Company shall be indemnified, defended and held harmless by the customer from any and all claims by any person relating to such customer's use of services so provided.

(F) No license under patents (other than the limited license to use) is granted by the Telephone Company or shall be implied or arise by estoppel, with respect to any service offered under this Guide.

(G) The Telephone Company's failure to provide or maintain services under this Guide shall be excused by labor difficulties, governmental orders, civil commotions, criminal actions taken against the Telephone Company, acts of God and other circumstances beyond the Telephone Company's reasonable control, subject to the Credit Allowance for a Service Interruption as set forth in 2.4.4 following.

2.1.4 Provision of Services

The Telephone Company, to the extent that such services are or can be made available with reasonable effort, and after provision has been made for the Telephone Company's telephone exchange services, will provide to the customer upon reasonable notice services offered in other applicable sections of this Guide at rates and charges specified therein.

2.1.5 Installation and Termination of Services

Except as provided for Expanded Interconnection Service specified in Section 17, the services provided under this Guide (A) will include any entrance cable or drop wiring and wire or intrabuilding cable to that point where provision is made for termination of the Telephone Company's outside distribution network facilities at a location at the customer-designated premises and (B) will be installed by the Telephone Company to such Point of Termination. The Telephone Company will work cooperatively with the customer to determine the location of the Point of Termination in accordance with the Telephone Company's standard operating procedures.

Each Access Service has only one Point of Termination per customer premises. Any additional terminations beyond such Point of Termination are the sole responsibility of the customer. Moves of the Point of Termination are handled as set forth in 6.5.4(C) and 7.2.1(D)(3).

ACCESS SERVICE

2. General Regulations (Cont'd)

2.1 Undertaking of the Telephone Company (Cont'd)

2.1.6 Maintenance of Services

- (A) The services provided under this Guide shall be maintained by the Telephone Company. The customer or others may not rearrange, move, disconnect, remove or attempt to repair any facilities provided by the Telephone Company, other than by connection or disconnection to any interface means used, except with the written consent of the Telephone Company.
- (B) Customer provided transmission facilities and equipment terminating in the Telephone Company wire center or Telephone Company access tandem for purposes of physical Expanded Interconnection Service (EIS), as set forth in Section 17, will not be maintained by the Telephone Company. Customer provided facilities and equipment terminating in Telephone Company manhole or similar location for virtual EIS will be maintained by the Telephone Company.

2.1.7 Changes, Substitutions and Rearrangements

Except as provided for equipment and systems subject to FCC Part 68 Regulations at 47 C.F.R Section 68.110(b), the Telephone Company may, where such action is reasonably required in the operation of its business:

- (A) Change the routing of access service traffic;
- (B) Change minimum protection criteria;
- (C) Change operating or maintenance characteristics of facilities; or
- (D) Change operations or procedures of the Telephone Company.

In case of any such substitution, change or rearrangement, the transmission parameters will be within the range as set forth in 6., 7. and 9. following. The Telephone Company shall not be responsible if any such substitution, change or rearrangement renders any customer furnished services obsolete or requires modification or alteration thereof or otherwise affects their use or performance. If such substitution, change or rearrangement materially affects the operating characteristics of the facility, the Telephone Company will provide reasonable notification to the customer in writing. Reasonable time will be allowed for any redesign and implementation required by the change in operating characteristics. The Telephone Company will work cooperatively with the customer to determine reasonable notification procedures.

ACCESS SERVICE

2. General Regulations (Cont'd)

2.1 Undertaking of the Telephone Company (Cont'd)

2.1.8 Refusal and Discontinuance of Service

(A) Unless the provisions of 2.2.1(B) or 2.5.1 following apply, if a customer fails to comply with the regulations set forth in: 2.1.6, Maintenance of Service; 2.2.2, Unlawful Use; 2.3.1, Damages; 2.3.4, Availability for Testing; 2.3.5, Balance; and 2.4, Payment Arrangements and Credit Allowances or, if applicable, 2.5.3, 2.5.4, 17.3.4 and 17.7.6(D), Expanded Interconnection Service (EIS) or fails to make any payment to be made by it on the dates and times herein specified, the Telephone Company may, on thirty (30) days written notice by Certified U.S. Mail or Overnight Delivery to the person designated by that customer to receive such notices of noncompliance:

- (1) Refuse additional applications for service and/or refuse to complete any pending orders for service by the non-complying customer; and/or
- (2) Discontinue the provision of the services to the noncomplying customer. In the case of such discontinuance, all applicable charges including termination charges shall become due.

If the Telephone Company does not refuse additional applications for service on the date specified in the thirty (30) days notice given pursuant to (1) above, or does not discontinue its provision of services involved on the date specified in the thirty (30) day notice given pursuant to (2) above and the customer's noncompliance continues, nothing contained herein shall preclude the Telephone Company's right to refuse additional applications for service to the non-complying customer without further notice.

ACCESS SERVICE

2. General Regulations (Cont'd)

2.1 Undertaking of the Telephone Company (Cont'd)

2.1.8 Refusal and Discontinuance of Service (Cont'd)

(A) (Cont'd)

(3) In addition to and not in limitation of the provisions of section 2.1.8(A) preceding, unless the provisions of 2.2.1(B) or 2.5.1 following apply, if a customer fails to comply with 2.4.1(B)(3) or with 2.4.1(A) following, including any bill payments to be made by it on the dates and times herein specified, the Telephone Company may take the actions specified in sections 2.1.8(A)(1) and 2.8.1(A)(2) with regard to services provided hereunder to that customer on fifteen (15) calendar days written notice, such notice period to start the day after the notice is sent by Overnight Delivery, if the customer has not complied with respect to amounts due in a subject bill and either:

- (a) the Telephone Company has sent the subject bill to the customer within seven (7) business days from the bill date, or
- (b) the Telephone Company has sent the subject bill to the customer more than thirty (30) calendar days before the notice under this section is given.

In all other cases, the Telephone Company will give thirty (30) calendar days written notice pursuant to sections 2.1.8(A). The Telephone Company will maintain records sufficient to validate the date upon which a bill was sent to a customer. Action will not be taken as specified in 2.1.8(A)(1) and 2.8.1(A)(2) with regard to the subject bill if the customer cures the noncompliance prior to the expiration of the fifteen (15) or thirty (30) days notice period, as applicable.

If the Telephone Company does not refuse additional applications for service on the date specified in the fifteen (15) days notice given pursuant to (3) above, or does not discontinue its provision of services involved on the date specified in the fifteen (15) day notice given pursuant to (3) above and the customer's noncompliance continues, nothing contained herein shall preclude the Telephone Company's right to refuse additional applications for service to the non-complying customer without further notice.

ACCESS SERVICE

2. General Regulations (Cont'd)

2.1 Undertaking of the Telephone Company (Cont'd)

2.1.8 Refusal and Discontinuance of Service (Cont'd)

(A) (Cont'd)

(4) If notice is given by Overnight Delivery under this section, it shall be performed by a reputable overnight delivery service such as, or comparable to, the U.S. Postal Service Express Mail, United Parcel Service, or Federal Express.

(5) The Provisions of section 2.1.8(A)(1), (2), and (3) shall not apply to charges that a customer does not pay based on submission of a good faith dispute pursuant to section 2.4.1(D)(1).

(B) When access service is provided by more than one Telephone Company, the Companies involved in providing the joint service may individually or collectively deny service to a customer for nonpayment. Service denial for such joint service will only include calls originating or terminating within, or transiting, the operating territory of the Telephone Companies initiating the service denial for nonpayment. When more than one of the joint providers must deny service to effectuate termination for nonpayment in cases where a conflict exists in the applicable tariff provisions, the tariff regulations of the end office Telephone Company shall apply for joint service discontinuance.

ACCESS SERVICE

2. General Regulations (Cont'd)

2.1 Undertaking of the Telephone Company (Cont'd)

2.1.9 Limitation of Use of Metallic Facilities

Signals applied to a metallic facility shall conform to the limitations set forth in Technical Reference PUB AS No. 1, Issue II*.

2.1.10 Notification of Service-Affecting Activities

The Telephone Company will provide the customer reasonable notification of service-affecting activities that may occur in normal operation of its business. Such activities may include, but are not limited to, equipment or facilities additions, removals or rearrangements, routine preventative maintenance and major switching machine change-out. Generally, such activities are not individual customer service specific, they affect many customer services. No specific advance notification period is applicable to all service-affecting activities. The Telephone Company will work cooperatively with the customer to determine the notification requirements.

2.1.11 Coordination with Respect to Network Contingencies

The Telephone Company intends to work cooperatively with the customer to develop network contingency plans in order to maintain maximum network capability following natural or man-made disasters which affect telecommunications services.

2.1.12 Provision and Ownership of Telephone Numbers

The Telephone Company reserves the reasonable right to assign, designate or change telephone numbers, any other call number designations associated with Access Services, or the Telephone Company serving central office prefixes associated with such numbers, when necessary in the conduct of its business. Should it become necessary to make a change in such number(s), the Telephone Company will furnish to the customer 6 months' notice, by Certified U.S. Mail, of the effective date and an explanation of the reason(s) for such change(s).

ACCESS SERVICE

2. General Regulations (Cont'd)

2.2 Use

2.2.1 Interference or Impairment

(A) The characteristics and methods of operation of any circuits, facilities or equipment provided by other than the Telephone Company, including customer transmission equipment and facilities used with Expanded Interconnection Services, and associated with the facilities utilized to provide services under this Guide shall not interfere with or impair service over any facilities of the Telephone Company, its affiliated companies, or its connecting and concurring carriers involved in its services, cause damage to their plant, impair the privacy of any communications carried over their facilities or create hazards to the employees of any of them or the public.

(B) Except as provided for equipment or systems subject to the FCC Part 68 Rules in 47 C.F.R Section 68.108, if such characteristics or methods of operation are not in accordance with (A) preceding, the Telephone Company will, where practicable, notify the customer that temporary discontinuance of the use of a service may be required; however, where prior notice is not practicable, nothing contained herein shall be deemed to preclude the Telephone Company's right to temporarily discontinue forthwith the use of a service if such action is reasonable under the circumstances. In case of such temporary discontinuance, the customer will be promptly notified and afforded the opportunity to correct the condition which gave rise to the temporary discontinuance. During such period of temporary discontinuance, credits as set forth in Section 2.7 following, are not applicable.

2.2.2 Unlawful Use

The service provided under this Guide shall not be used for an unlawful purpose.

ACCESS SERVICE

2. General Regulations (Cont'd)

2.2 Use (Cont'd)

2.2.3 Commingling

Except as provided in Section 51.318 of the Federal Communications Commission's rules, telecommunications carriers who obtain unbundled network elements or combinations of unbundled network elements pursuant to a Statement of Generally Available Terms, under Section 252 of the Act, or pursuant to an interconnection agreement with the Telephone Company, may connect, combine, or otherwise attach such unbundled network elements or combinations of unbundled network elements to access services purchased under this Guide except to the extent such agreement (1) expressly prohibits such commingling; or (2) does not address commingling and the requesting carrier has not negotiated an interconnection agreement (or amendment) expressly permitting such commingling. The rates, terms, and conditions of this Guide will apply to the access services that are commingled. Unbundled network elements or combinations of unbundled network elements that are commingled with access services do not constitute a shared use arrangement as set forth in this Guide, and are therefore not eligible for adjustment of charges under such provisions.

ACCESS SERVICE

2. General Regulations (Cont'd)

2.3 Obligations of the Customer

2.3.1 Damages

The customer shall reimburse the Telephone Company for damages to Telephone Company facilities utilized to provide services under this Guide caused by the negligence or willful act of the customer, or resulting from the customer's improper use of the Telephone Company facilities, or due to malfunction of any facilities or equipment provided by other than the Telephone Company. Nothing in the foregoing provision shall be interpreted to hold one customer liable for another customer's actions. The Telephone Company will, upon reimbursement for damages, cooperate with the customer in prosecuting a claim against the person causing such damage and the customer shall be subrogated to the right of recovery by the Telephone Company for the damages to the extent of such payment.

2.3.2 Ownership of Facilities and Theft

Facilities utilized by the Telephone Company to provide service under the provisions of this Guide shall remain the property of the Telephone Company. Such facilities shall be returned to the Telephone Company by the customer, whenever requested, within a reasonable period following the request in as good condition as reasonable wear will permit.

2.3.3 Equipment Space and Power

(A) Except as specified in (B), the customer shall furnish or arrange to have furnished to the Telephone Company, at no charge, equipment space and electrical power required by the Telephone Company to provide services under this Guide at the points of termination of such services. The selection of ac or dc power shall be mutually agreed to by the customer and the Telephone Company. The customer shall also make necessary arrangements in order that the Telephone Company will have access to such spaces at reasonable times for installing, testing, repairing or removing Telephone Company services.

(B) Where available, the Telephone Company shall make available wire center or Telephone Company access tandem floor space and electrical power by the customer for the provision of Expanded Interconnection Service at charges set forth in Section 17.

ACCESS SERVICE

2. General Regulations (Cont'd)

2.3 Obligations of the Customer (Cont'd)

2.3.4 Availability for Testing

The services provided under this Guide shall be available to the Telephone Company at times mutually agreed upon in order to permit the Telephone Company to make tests and adjustments appropriate for maintaining the services in satisfactory operating condition. Such tests and adjustments shall be completed within a reasonable time. No credit will be allowed for any interruptions involved during such tests and adjustments.

2.3.5 Balance

All signals for transmission over the services provided under this Guide shall be delivered by the customer balanced to ground except for ground start and duplex (DX) and McCulloh-Loop (Alarm System) type signaling.

2.3.6 Design of Customer Services

Subject to the provisions of 2.1.7 preceding, the customer shall be solely responsible, at its own expense, for the overall design of its services and for any redesigning or rearrangement of its services which may be required because of changes in facilities, operations or procedures of the Telephone Company, minimum protection criteria or operating or maintenance characteristics of the facilities.

2.3.7 References to the Telephone Company

The customer may advise End Users that certain services are provided by the Telephone Company in connection with the service the customer furnishes to End Users; however, the customer shall not represent that the Telephone Company jointly participates in the customer's services.

ACCESS SERVICE

2. General Regulations (Cont'd)

2.3 Obligations of the Customer (Cont'd)

2.3.8 Claims and Demands for Damages

(A) With respect to claims of patent infringement made by third persons, the customer shall defend, indemnify, protect and save harmless the Telephone Company from and against all claims arising out of the combining with, or use in connection with, the services provided under this Guide, any circuit, apparatus, system or method provided by the customer.

(B) The customer shall defend, indemnify and save harmless the Telephone Company from and against any suits, claims, losses or damages, including punitive damages, attorney fees and court costs by third persons arising out of the construction, installation, operation, maintenance, or removal of the customer's circuits, facilities, or equipment connected to the Telephone Company's services provided under this Guide, including, without limitation, Workmen's Compensation claims, actions for infringement of copyright and/or unauthorized use of program material, libel and slander actions based on the content of communications transmitted over the customer's circuits, facilities or equipment, and proceedings to recover taxes, fines, or penalties for failure of the customer to obtain or maintain in effect any necessary certificates, permits, licenses, or other authority to acquire or operate the services provided under this Guide; provided, however, the foregoing indemnification shall not apply to suits, claims, and demands to recover damages for damage to property, death, or personal injury unless such suits, claims or demands are based on the tortuous conduct of the customer, its officers, agents or employees.

(C) The customer shall defend, indemnify and save harmless the Telephone Company from and against any suits, claims, losses or damages, including punitive damages, attorney fees and court costs by the customer or third parties arising out of any act or omission of the customer in the course of using services provided under this Guide.

ACCESS SERVICE

2. General Regulations (Cont'd)

2.3 Obligations of the Customer (Cont'd)

2.3.9 Coordination with Respect to Network Contingencies

The customer shall, in cooperation with the Telephone Company, coordinate in planning the actions to be taken to maintain maximum network capability following natural or man-made disasters which affect telecommunications services.

2.3.10 Sectionalization and Trouble Reporting

The customer will be responsible for reporting troubles sectionalized to Telephone Company facilities and/or equipment. When trouble cannot be clearly sectionalized to the Telephone Company facilities and/or equipment, the Telephone Company will test cooperatively or independently to assist in trouble sectionalization.

2.3.11 RESERVED

ACCESS SERVICE

2. General Regulations (Cont'd)

2.4 Payment Arrangements

2.4.1 Payment of Rates, Charges and Deposits

(A) Deposits

The Telephone Company will, in order to safeguard its interests, only require a customer which has a proven history of late payments to the Telephone Company or does not have established credit, to make a deposit prior to or at any time after the provision of a service to the customer to be held by the Telephone Company as a guarantee of the payment of rates and charges. The Telephone Company will notify the customer of a deposit requirement by Overnight Delivery. The customer will be required to make payment of such deposit prior to the provision of service in those cases where the customer has not established credit with the Telephone Company, or otherwise within fifteen (15) business days of such notice. Such notice will start the day after the notice is sent by Overnight Delivery. No such deposit will be required of a customer which is a successor of a company which has established credit and has no history of late payments to the Telephone Company. Such deposit may not exceed the actual or estimated rates and charges for the service for a two month period. The fact that a deposit has been made in no way relieves the customer from complying with the Telephone Company's regulations as to the prompt payment of bills. At such time as the provision of the service to the customer is terminated, the amount of the deposit will be credited to the customer's account and any credit balance which may remain will be refunded.

Such a deposit will be refunded or credited to the account when the customer has established credit or, in any event, after the customer has established a one-year prompt payment record at any time prior to the termination of the provision of the service to the customer. In case of a cash deposit, for the period the deposit is held by the Telephone Company, the customer will receive simple annual interest at a rate of 1% per month or 12% annually. Should a deposit be credited to the customer's account, as indicated above, no interest will accrue on the deposit from the date such deposit is credited to the customer's account.

ACCESS SERVICE

2. General Regulations (Cont'd)

2.4 Payment Arrangements (Cont'd)

2.4.1 Payment of Rates, Charges and Deposits (Cont'd)

(B) Payment of Rates and Charges

The Telephone Company shall bill on a current basis all charges incurred by and credits due to the customer under this Guide attributable to services established or discontinued during the preceding billing period. In addition, the Telephone Company shall bill in advance charges for all services to be provided during the ensuing billing period except for charges associated with service usage and for the Federal Government which will be billed in arrears. The bill day (i.e., the billing date of a bill for a customer for Access Service under this Guide), the period of service each bill covers and the payment date will be as follows:

- (1) For End User Access Service and Presubscription Service, the Telephone Company will establish a bill day each month for each end user account. The bill will cover End User Access Service charges for the ensuing billing period except for End User Access Service for the Federal Government which will be billed in arrears. Any applicable Presubscription Charges, any known unbilled charges for prior periods and any known unbilled adjustments for prior periods for End User Access Service and Presubscription Service will be applied to this bill. Such bills are due when rendered.
- (2) For Special Access Service, and Miscellaneous Service charges, the Telephone Company will establish a bill day each month for each customer account. The bill will cover nonusage sensitive service charges for the ensuing billing period for which the bill is rendered, any known unbilled nonusage sensitive charges for prior periods and unbilled usage charges for the period after the last bill day through the current bill day. Any known unbilled usage charges for prior periods and known unbilled adjustments will be applied to this bill. Payment for such bills is due as set forth in (3) following. If payment is not received by the payment date, as set forth in (3) following in immediately available funds, a late payment penalty will apply as set forth in (C) following.

ACCESS SERVICE

2. General Regulations (Cont'd)

2.4 Payment Arrangements (Cont'd)

2.4.1 Payment of Rates, Charges and Deposits (Cont'd)

(B) Payment of Rates and Charges (Cont'd)

- (3) All bills dated as set forth in (2) preceding for service, provided to the customer by the Telephone Company are due 31 days (payment date) after the bill date or by the next bill date (i.e., same date in the following month as the bill date), whichever is the shortest interval, except as provided herein, and are payable in immediately available funds. If such payment date would cause payment to be due on a Saturday, Sunday or Holiday (i.e., New Year's Day, Independence Day, Labor Day, Thanksgiving Day, Christmas Day, the first Tuesday in November and the day when Washington's Birthday, Memorial Day or Columbus Day is legally observed), payment for such bills will be due from the customer as follows:

If such payment date falls on Sunday or on a Holiday which is observed on a Monday, the payment date shall be the first non-Holiday day following such Sunday or Holiday. If such payment date falls on a Saturday or on a Holiday which is observed on Tuesday, Wednesday, Thursday or Friday, the payment date shall be the last non-Holiday day preceding such Saturday or Holiday.

(C) Late Payment Penalty

If the entire amount billed is not received by the Telephone Company in immediately available funds by the payment date, an additional charge (late payment charge) equal to 1/365th of the percentage rate for deposit interest as that in 2.4.1(A) of the unpaid balance will be applied for each day or portion thereof that an outstanding balance remains.

ACCESS SERVICE

2. General Regulations (Cont'd)

2.4 Payment Arrangements (Cont'd)

2.4.1 Payment of Rates, Charges and Deposits (Cont'd)

(D) Billing Disputes

In the event that a billing dispute occurs concerning any charges billed to the customer by the Telephone Company the following regulations will apply.

- (1) A good faith dispute requires the customer to provide a written claim to the Telephone Company. Instructions for submitting a dispute can be obtained by calling the billing inquiry number shown on the customer's bill, or, by accessing the Telephone Company website also shown on the customer's bill. The written notice should contain the information specified in (2) following.
- (2) The date of the dispute shall be the date on which the customer furnishes the Telephone Company the following account information. Such written notice must identify in detail the basis for the dispute, and if the customer withholds disputed amounts, it must identify the account number under which the bill has been rendered, the date of the bill and the specific items on the bill being disputed, to permit the Telephone Company to investigate the merits of the dispute.
- (3) The date of resolution shall be the date on which the Telephone Company completes its investigation of the dispute, notifies the customer of the disposition and applies a credit for the amount of the dispute resolved in the customer's favor or late payment penalty as appropriate. The Telephone Company will work cooperatively with any customer to resolve billing disputes.
- (4) If a billing dispute is resolved in favor of the Telephone Company, any payments withheld pending resolution of the dispute shall be subject to the late payment penalty as set forth in (C) preceding.

ACCESS SERVICE

2. General Regulations (Cont'd)

2.4 Payment Arrangements (Cont'd)

2.4.1 Payment of Rates, Charges and Deposits (Cont'd)

(D) Billing Disputes (Cont'd)

- (5) If the customer pays the bill in full by the payment due date, and later initiates a billing dispute, penalty interest may be applicable.

If the billing dispute is resolved in favor of the customer, the customer shall receive a credit from the Telephone Company. This credit will be an amount equal to the disputed amount resolved in the customers' favor times a penalty factor of 1% per month or 12% annually. The penalty factor will apply from the date of the customer's payment through the date on which the credit is posted to the customer's account.

If the dispute is resolved in favor of the Telephone Company, neither a late payment charge nor a penalty interest charge is applicable.

(C)

(C)

ACCESS SERVICE

2. General Regulations (Cont'd)

2.4 Payment Arrangements (Cont'd)

2.4.1 Payment of Rates, Charges and Deposits (Cont'd)

(E) Billing Adjustments and Rounding

Adjustments for the quantities of services established or discontinued in any billing period beyond the minimum period set forth for services in other sections of this Guide will be prorated to the number of days or major fraction of days based on a 30 day month. When a rate as set forth in this Guide is shown to more than two decimal places, the charges will be determined using the rate shown. The resulting amount will then be rounded to the nearest penny (i.e., rounded to two decimal places).

(F) Provision of Access Service Billing and Bill Verification

- (1) The Telephone Company will, upon reasonable request and if available, furnish such detailed information as may be required for verification of any bill.
- (2) The customer will receive its monthly bills in: 1) a standard paper format, 2) a paper format bill summary with an electronic transmission to provide the detailed information of the bill, or 3) on a storage device (CD ROM). The rules and regulations concerning payment arrangements and credit allowances described in this Section 2.4.1 apply to all primary monthly access bills, regardless of the chosen bill medium. Additional copies of the customer's bill may be provided in standard paper format at the rates and charges set forth in (3) following.

- | | |
|--|-----------------------|
| (3) Additional copies of the customer's monthly bill or service and features record in standard paper format, per page | <u>Rate</u>
\$0.00 |
|--|-----------------------|

ACCESS SERVICE

2. General Regulations (Cont'd)

2.4 Payment Arrangements (Cont'd)

2.4.2 Minimum Periods

The minimum period for which services are provided are for which rates and charges are applicable is one month except as otherwise specified. The minimum period for which DS3 services are provided and which rates are applicable are in Section 7. The minimum periods for which Expanded Interconnection Services are provided and which rates are applicable are in Section 17. The minimum periods for Optical Networking term plan services are provided and which rates and charges are applicable are in Section 20. The minimum period for which service is provided and for which rates and charges are applicable for a Specialized Service or Arrangement provided on an individual case basis as set forth in 12 following, is one month unless a different minimum period is established which the individual case filing. As specified in Section 5.3.3 following, when a service is discontinued prior to the expiration of the minimum period, charges are applicable, whether the service is used or not, as follows:

(C)

(A) When a service with a one month minimum period is discontinued prior to the expiration of the minimum period, a one month charge will apply at the rate level in effect at the time service is discontinued.

(B) When a service with a minimum period greater than one month is discontinued prior to the expiration of the minimum period, the applicable charge will be the lesser of:

(1) the Telephone Company's total nonrecoverable costs less the net salvage value for the discontinued service, or

(2) the total monthly charges, at the rate level in effect at the time service is discontinued, for the remainder of the minimum period.

(C)

2.4.3 Cancellation of an Order for Service

Provisions for the cancellation of an order for service are set forth in Section 5.3.2 following.

2.4.4 Reserved for Future Use

ACCESS SERVICE

2. General Regulations (Cont'd)

2.4 Payment Arrangements (Cont'd)

2.4.5 Re-establishment of Service Following Fire, Flood or Other Occurrence

(A) Nonrecurring Charges Do Not Apply

Charges do not apply for the re-establishment of service following a fire, flood or other occurrence attributed to an Act of God provided that:

- (1) The service is of the same type as was provided prior to the fire, flood or other occurrence.
- (2) The service is for the same customer.
- (3) The service is at the same location on the same premises.
- (4) The re-establishment of service begins within 60 days after Telephone Company service is available. (The 60 day period may be extended a reasonable period if the renovation of the original location on the premises affected is not practical within the allotted time period).

(B) Nonrecurring Charges Apply

Nonrecurring Charges apply for establishing service at a different location on the same premises or at a different premises pending re-establishment of service at the original location.

2.4.6 Title or Ownership Rights

The payment of rates and charges by Customers for the services offered under the provisions of this Guide does not assign, confer or transfer title or ownership rights to proposals or facilities developed or utilized, respectively, by the Telephone Company in the provision of such services.

ACCESS SERVICE

2. General Regulations (Cont'd)

2.4 Payment Arrangements (Cont'd)

2.4.7 Access Services Provided by More Than One Telephone Company

The Telephone Company will perform the rating and billing of Access Services under this Guide where more than one Telephone Company is involved in the provision of Access Service as set forth in (A) or (B) following. The Multiple Company Billing arrangement, as set forth in (B) following, will be used for all Special Access Services.

(A) RESERVED

ACCESS SERVICE

2. General Regulations (Cont'd)

2.4 Payment Arrangements (Cont'd)

2.4.7 Access Services Provided by More Than One Telephone Company (Cont'd)

(B) Multiple Company Billing

- (1) For access services subject to Multiple Company Billing, the customer will be billed in accordance with the Exchange Carrier Standards Association's Multiple Exchange Carrier Access Billing Guidelines (MECAB) and Multiple Exchange Carrier Ordering and Design Guidelines (MECOD). The following method will be used:

Multiple Bill -The customer will receive a bill from each Telephone Company providing the access service. Multiple bills will include all charges applicable to the individual portion of the access service provided by each Telephone Company. Such bills will include the following information in accordance with the MECAB Guidelines:

- Billing Account Reference (BAR)
- Billing Account Cross Reference (BACR)
- Billing Account Number (BAN)
- End Office NPA/NXX or End Office CLLI Code
- Common EC Circuit Identifiers (Special Access)
- Billing Percentages as listed in NECA Tariff No. 4
- Percent Interstate Usage (PIU)
- Usage "from" and "through" dates

The choice of billing method shall be determined by the Telephone Companies involved. The Telephone Company will notify the customer which method applies when the customer orders access service and will provide the customer thirty days' notice in the event that the billing method is changed.

ACCESS SERVICE

2. General Regulations (Cont'd)

2.4 Payment Arrangements (Cont'd)

2.4.7 Access Services Provided by More Than One Telephone Company (Cont'd)

(B) Multiple Company Billing (Cont'd)

(2) RESERVED

ACCESS SERVICE

2. General Regulations (Cont'd)

2.4 Payment Arrangements (Cont'd)

2.4.7 Access Services Provided by More Than One Telephone Company (Cont'd)

(B) Multiple Company Billing (Cont'd)

(3) For Special Access Services, the Telephone Company will determine the applicable charges as follows:

(a) Determine the distance in airline miles using the V&H method set forth in National Exchange Carrier Association Tariff No. 4 between the locations involved; i.e., the serving wire center associated with a customer designated premise and an end office, or a Telephone Company hub, or two Telephone Company hubs, a hub to an end office, or a hub to a Telephone Company access tandem.

(b) The airline distance in miles developed in (a) preceding will be multiplied by the Special Access Circuit Mileage-Per Mile rate element times the billing percentage to determine the appropriate charges. The billing percentage is that portion of circuit mileage to be billed by each company involved in providing Access Services to the customer. Billing percentages are listed in National Exchange Carrier Association Tariff FCC No. 4.

ACCESS SERVICE

- 2. General Regulations (Cont'd)
 - 2.4 Payment Arrangements (Cont'd)
 - 2.4.7 Access Services Provided by More Than One Telephone Company (Cont'd)
 - (B) Multiple Company Billing (Cont'd)
 - (3) (Cont'd)
 - (c) For Special Access, the total Circuit Mileage charges shall be the Circuit Mileage-Per Mile charge determined in (b) preceding plus the Circuit Mileage-Fixed charges. The Circuit Mileage-Fixed charge is always applied in full, once per circuit mileage facility, whether the Telephone Company provides one, or more than one, circuit mileage facility termination(s). The Circuit Mileage-Fixed rate does not apply when the Telephone Company provides an intermediate portion of a circuit mileage facility and no circuit mileage terminations.
 - (d) RESERVED
 - (e) All other appropriate recurring and nonrecurring charges in each Telephone Company's access tariff and Service Guides and Pricelists are applicable. The Special Access Nonrecurring Charge for circuit installation applies in full once per Circuit Termination provided by the Telephone Company.

ACCESS SERVICE

2. General Regulations (Cont'd)

2.4 Payment Arrangements (Cont'd)

2.4.7 Access Services Provided by More Than One Telephone Company (Cont'd)

(B) Multiple Company Billing (Cont'd)

ACCESS SERVICE

2. General Regulations (Cont'd)

2.5 Connections

2.5.1 General

Equipment and Systems (i.e., terminal equipment, multiline terminating systems and communications systems) may be connected with Special Access Service furnished by the Telephone Company where such connection or interconnection is made in accordance with the provisions specified in Technical Reference PUB AS No. 1, Issue II, and in Section 2.1 preceding.

2.5.2 Standard Access Service Connections

Access services are provided by means of wire, fiber optics, radio or any other suitable technology or a combination thereof. Special Access service connections are made directly, through a Telephone Company hub where bridging or multiplexing functions are performed, or through a DS3 Premises Multiplexer multiplexing arrangement at a customer designated premises where multiplexing functions are performed. These connections can either be analog or digital.

ACCESS SERVICE

2. General Regulations (Cont'd)

2.6 Definitions

Certain terms used herein are defined as follows:

Access Area

The term "Access Area" denotes a specific calling area serviced by one or more Central Offices associated with the various Switched Access Services offered under this Guide. The size and configuration of the Access Area a customer obtains is dependent upon the Feature Group type and the specific characteristics of the Central Office or Telephone Company Access Tandem Network in which the connection is made.

Access Code

The term "Access Code" applies to Switched Access Service. It denotes a uniform seven digit code dialed by an end user to access an Interexchange Carrier's facilities. The five or seven digit FGD code has the form 101XXXX, and the seven digit FGB code has the form 950-XXXX.

Access Minutes

The term "Access Minutes" denotes that usage of exchange facilities in interstate or foreign service for the purpose of calculating chargeable usage. On the originating end of an interstate or foreign call, usage is measured from the time the originating end user's call is delivered by the Telephone Company to and acknowledged as received by the customer's facilities connected with the originating exchange. On the terminating end of an interstate or foreign call, usage is measured from the time the call is received by the end user in the terminating exchange. Timing of usage at both originating and terminating ends of an interstate or foreign call shall terminate when the calling or called party disconnects, whichever event is recognized first in the originating and terminating exchanges, as applicable.

Access Tandem

The term "Access Tandem" denotes a Telephone Company switching system that provides a concentration and distribution function for originating and/or terminating traffic between end offices and a customer's premises.

ACCESS SERVICE

2. General Regulations (Cont'd)

2.6 Definitions (Cont'd)

Access Tandem Network

The term "Access Tandem Network" denotes the network of trunk groups that provide a concentration and distribution function for originating and/or terminating Switched Access traffic between a single Telephone Company access tandem and Telephone Company subtending end offices.

Add/Drop Multiplexing

The term "Add/Drop Multiplexing" denotes a multiplexing function that allows lower level signals to be added or dropped with the remaining traffic continuing through the network.

Agent

The term "Agent," as used in Section 8.5 of this Guide, is defined as that person or entity that the Telephone Company acknowledges as the possessor of authority to make decisions pertaining to instrument placement, subscription authorization, and access or usage control of Pay Telephone Service or, that person or entity duly authorized to act in that capacity by the owner of the premises.

Aggregator

The term "Aggregator" denotes any individual, partnership, association, joint-stock company, trust or corporation that, in the ordinary course of its operations, makes telephones available to the public or to transient users of its premises, for interstate telephone calls using a provider of operator services.

Answer Message

The term "Answer Message" denotes an SS7 message sent in the backward direction to indicate that the call has been answered.

Answer/Disconnect Supervision

The term "Answer/Disconnect Supervision" denotes the transmission of the switch trunk equipment supervisory signal (off-hook or on-hook) to the customer's point of termination as an indication that the called party has answered or disconnected.

ACCESS SERVICE

2. General Regulations (Cont'd)

2.6 Definitions (Cont'd)

Attenuation Distortion

The term "Attenuation Distortion" denotes the difference in loss at specified frequencies relative to the loss at 1004 Hz, unless otherwise specified.

Balance (100 Type) Test Line

The term "Balance (100 Type) Test Line" denotes an arrangement in an end office which provides for balance and noise testing.

Basic Service Element

The term "Basic Service Element (BSE)" denotes an unbundled service option available only with Basic Serving Arrangements.

Basic Serving Arrangement

The term "Basic Serving Arrangement (BSA)" denotes a category of Switched Access Service differentiated by technical characteristics, e.g., line side versus trunk side connection at the Telephone Company's first point of switching.

Bit

The term "Bit" denotes the smallest unit of information in the binary system of notation.

Business Day

The term "Business Day" denotes the times of day that a company is open for business. Generally, in the business community, these are 8:00 or 9:00 A.M. to 5:00 or 6:00 P.M., respectively, with an hour for lunch, Monday through Friday, resulting in a standard forty (40) hour work week. However, Business Day hours for the Telephone Company may vary based on company policy, union contract and location. To determine such hours for an individual company, or company location, contact the issuing officer at the address shown on Title Page 1.

ACCESS SERVICE

2. General Regulations (Cont'd)

2.6 Definitions (Cont'd)

Busy Hour Minutes of Capacity (BHMC)

The term "Busy Hour Minutes of Capacity (BHMC)" denotes the customer specified maximum amount of Switched Access Service access minutes the customer expects to be handled in an end office switch during any hour in an 8:00 A.M. to 11:00 P.M. period for the Switched Access Arrangement ordered. This customer furnished BHMC quantity is the input data the Telephone Company uses to determine the number of transmission paths or facility requirements for the Switched Access Arrangement ordered.

Call

The term "Call" denotes a customer attempt for which the complete address code (e.g., 0-, 911, or 10 digits) is provided to the serving dial tone office.

Carrier or Common Carrier

See Interexchange Carrier.

Carrier Identification Code

The term "Carrier Identification Code (CIC)" denotes the uniform access code associated with a specific Interexchange Carrier.

Carrier Identification Parameter

The term "Carrier Identification Parameter (CIP)" denotes a field in the SS7 Initial Address Message (IAM) that identifies and transmits the CIC information in a forward direction to an IC customer.

CCS

The term "CCS" denotes a hundred call seconds, which is a standard unit of traffic load that is equal to 100 seconds of usage or capacity of a group of servers (e.g., trunks).

Cellular Mobile Carrier (CMC)

The term "Cellular Mobile Carrier (CMC)" denotes a Common Carrier authorized by the Federal Communications Commission to provide cellular mobile radio telecommunications services.

ACCESS SERVICE

2. General Regulations (Cont'd)

2.6 Definitions (Cont'd)

Central Office

The term "Central Office" denotes a local Telephone Company switching system where Telephone Exchange Service customer station loops are terminated for purposes of interconnection to each other and to trunks.

Central Office Prefix

The term "Central Office Prefix" denotes the first three digits (NXX) of the seven digit telephone number assigned to a customer's Telephone Exchange Service when dialed on a local basis.

Centralized Automatic Reporting on Trunks Testing

The term "Centralized Automatic Reporting on Trunks Testing" denotes a type of testing which includes the capacity for measuring operational and transmission parameters.

Channel Service Unit

The term "Channel Service Unit" denotes customer premises equipment which performs one or more of the following functions: termination of a digital facility, regeneration of digital signals, detection and/or correction of signal format error, and remote loop back.

Channelize

The term "Channelize" denotes the process of multiplexing~demultiplexing wider bandwidth or higher speed channels into narrow band-width or lower speed channels.

Circuit(s)

The term "Circuit(s)" denotes an electrical or photonic, in the case of fiber optic-based transmission systems, communications path between two or more points of termination.

ACCESS SERVICE

2. General Regulations (Cont'd)

2.6 Definitions (Cont'd)

Circuit Code

The term "Circuit Code" denotes the service class routing of an SS7 call that indicates the interexchange carrier trunk group to which the traffic will be routed (e.g., 0+, 0-, 500, 900, etc.)

C-Message Noise

The term "C-Message Noise" denotes the frequency weighted average noise within an idle voice channel. The frequency weighing, called C-message, is used to simulate the frequency characteristic of the 500-type telephone set and the hearing of the average subscriber.

C-Notched Noise

The term "C-Notched Noise" denotes the C-message frequency weighted noise on a voice channel with a holding tone, which is removed at the measuring end through a notch (very narrow band) filter.

Coin Station

The term "Coin Station" denotes a location where Telephone Company equipment is provided in a public or semipublic place where Telephone Company customers can originate telephone communications and pay the applicable charges by inserting coins into the equipment.

Concatenated

The term "Concatenated" denotes the linking together of various data structures, e.g., two bandwidths joined to form a single bandwidth.

Common Channel Signaling System 7 Network (CCS7)

The term "Common Channel Signaling System 7 Network (CCS7)" denotes a dedicated out-of-band signaling network which utilizes Signaling System 7 (SS7) protocol to provide call handling and data base access services.

ACCESS SERVICE

2. General Regulations (Cont'd)

2.6 Definitions (Cont'd)

Common Line

The term "Common Line" denotes a line, trunk, pay telephone line or other facility provided under the general and/or local exchange service tariffs of the Telephone Company, terminated on a central office switch. A common line--residence is a line or trunk provided under the residence regulations of the general and/or local exchange service tariffs. A common line-business is a line provided under the business regulations of the general and/or local exchange service tariffs.

Communications System

The term "Communications System" denotes channels and other facilities which are capable of communications between terminal equipment provided by other than the Telephone Company.

Competitive County

The term "Competitive County" denotes that the geographic unit of a county or county-equivalent that passes or has passed a competitive market test specified by the FCC. Competitive County also denotes a county or county-equivalent that failed a competitive market test specified by the FCC, but was granted Phase II, Level 2 pricing flexibility prior to June 1, 2017.

(N)
|
(N)

Customer(s)

The term "Customer(s)" denotes any individual, partnership, association, joint-stock company, trust corporation, or governmental entity or other entity which subscribes to the services offered under this Guide.

Data Transmission (107 Type) Test Line

The term "Data Transmissions (107 Type) Test Line" denotes an arrangement which provides for a connection to a signal source which provides test signals for one-way testing of data and voice transmission parameters.

Decibel

The term "Decibel" denotes a unit used to express relative differences in power, usually between acoustic or electric signals, equal to ten (10) times the common logarithm of the ratio of two signal powers.

Decibel Reference Noise C-Message Weighting

The term "Decibel Reference Noise C-Message Weighting" denotes noise power measurements with C-Message Weighting in decibels relative to a reference 1000 Hz tone of 90 dB below 1 milliwatt.

ACCESS SERVICE

2. General Regulations (Cont'd)

2.6 Definitions (Cont'd)

Decibel Reference Noise C-Message Referenced to 0

The term "Decibel Reference Noise C-Message Referenced to 0" denotes noise power in "Decibel Reference Noise C-Message Weighing" referred to or measured at a zero transmission level point.

Disconnect Non-Recurring Charge (N)

In addition to any other charges associated with discontinuance of services, the Telephone Company will charge a Disconnect Non-Recurring Charge to discontinue services. This charge applies on a per circuit basis.

(N)

Dual Tone Multifrequency Address Signaling

The term "Dual Tone Multifrequency Address Signaling" denotes a type of signaling that is an optional feature of Switched Access Feature Group A and BSA-A. It may be utilized when Feature Group A or BSA-A is being used in the terminating direction (from the point of termination with the customer to the local exchange and office). An office arranged for Dual Tone Multifrequency Signaling would expect to receive address signals from the customer in the form of Dual Tone Multifrequency signals.

Echo Control

The term "Echo Control" denotes the control of reflected signals in a telephone transmission path.

Echo Path Loss

The term "Echo Path Loss" denotes the measure of reflected signal at a 4-wire point of interface without regard to the send and receive Transmission Level Point.

Echo Return Loss

The term "Echo Return Loss" denotes a frequency weighted measure of return loss over the middle of the voiceband (approximately 500 to 2500 Hz), where talker echo is most annoying.

Effective 2-Wire

The term "Effective 2-Wire" denotes a condition which permits the simultaneous transmission in both directions over a channel, but it is not possible to insure independent information transmission in both directions. Effective 2-wire channels may be terminated with 2-wire or 4-wire interfaces.

ACCESS SERVICE

2. General Regulations (Cont'd)

2.6 Definitions (Cont'd)

Effective 4-Wire

The term "Effective 4-Wire" denotes a condition which permits the simultaneous independent transmission of information in both directions over a channel. The method of implementing effective 4-wire transmission is at the discretion of the Telephone Company (physical, time domain, frequency-domain separation or echo cancellation techniques). Effective 4-wire channels may be terminated with a 2-wire interface at the customer's premises. However, when terminated 2-wire, simultaneous independent transmission cannot be supported because the two wire interface combines the transmission paths into a single path.

End Office Switch

The term "End Office Switch" denotes a local Telephone Company switching system where Telephone Exchange Service customer station loops are terminated for purposes of interconnection to each other and to trunks. Included may be Remote Switching Modules and Remote Switching Systems served by a host office in a different wire center.

End User

The term "End User" denotes any customer of interstate or foreign telecommunications service that is not a carrier, except that a carrier shall be deemed to be an "end user" to the extent that such carrier uses a telecommunications service for administrative purposes, without making such service available to others, directly or indirectly.

Entry Switch

See First Point of Switching.

Envelope Delay Distortion

The term "Envelope Delay Distortion" denotes a measure of the linearity of the phase versus frequency of a channel.

ACCESS SERVICE

2. General Regulations (Cont'd)

2.6 Definitions (Cont'd)

Equal Level Echo Path Loss

The term "Equal Level Echo Path Loss" (ELEPL) denotes the measure of Echo Path Loss (EPL) at a 4-wire interface which is corrected by the difference between the send and receive Transmission Level Point (TLP). [ELEPL = TLP (send) + TLP (receive)]

Exchange

The term "Exchange" denotes a unit generally smaller than a local access and transport area, established by the Telephone Company for the administration of communications service in a specified area which usually embraces a city, town or village and its environs. It consists of one or more central offices together with the associated facilities used in furnishing communications service within the area. One or more designated exchanges comprise a given local access and transport area.

Existing Suitable Space

The term "Existing Suitable Space" denotes a space in which ac/dc power, heat and air conditioning, battery and generator back-up power, and other requirements necessary for provision of wire center or access tandem equipment currently exists.

Exit Message

The term "Exit Message" denotes an SS7 message sent to an end office by the Telephone Company tandem switch to mark the Connect Time when the Telephone Company's tandem switch sends an Initial Address Message to a customer.

Expected Measured Loss

The term "Expected Measured Loss" denotes a calculated loss which specifies the end-to-end 1004-Hz loss on a terminated test connection between two readily accessible manual or remote test points. It is the sum of the inserted connection loss and test access loss including any test pads.

ACCESS SERVICE

2. General Regulations (Cont'd)

2.6 Definitions (Cont'd)

Extended Area Service

The term "Extended Area Service" denotes a telephone exchange service in which a customer in one exchange can call a local number in another exchange that is part of the extended area without paying a toll charge.

Extensible Markup Language (XML)

The term "Extensible Markup Language (XML)" denotes a simple, very flexible text format that is used in the exchange of a wide variety of data on the Web and elsewhere.

Facility

The term "Facility" denotes generically the various transmission media used for the transmission of telecommunications service. This included, but is not limited to, cable (copper pair, coaxial and fiber optic) and microwave radio equipment.

Field Identifier

The term "Field Identifier" denotes two to four characters that are used on service orders to convey specific instructions. Field Identifiers may or may not have associated data. Selected Field Identifiers are used in Telephone Company billing systems to generate nonrecurring charges.

First Come - First Served

The term "First Come - First Served" denotes a procedure followed by the Telephone Company to process fully completed Access Orders according to the sequence in which they are received.

First Point of Switching

The term "First Point of Switching" denotes the first Telephone Company location at which switching occurs on the terminating path of a call proceeding from the customer premises to the terminating end office and, at the same time, the last Telephone Company location at which switching occurs on the originating path of a call proceeding from the originating end office to the customer premises.

ACCESS SERVICE

2. General Regulations (Cont'd)

2.6 Definitions (Cont'd)

Flexible Automatic Number Identification (FLEX ANI)

The term "Flexible Automatic Number Identification" denotes an optional feature or Basic Service Element that provides additional values for the information indicator digits available with the ANI feature on originating calls. These additional digits identify the type of line that is originating the call for billing, screening and routing purposes.

Frame

The term "Frame" denotes a group of data bits, in specific format, with a flag at either end to indicate the beginning and end of the frame. The defined format enables network equipment to recognize the meaning and purpose of specific bits.

Frequency Shift

The term "Frequency Shift" denotes the change in the frequency of a tone as it is transmitted over a channel.

Grandfathered

The term "Grandfathered" denotes Terminal Equipment, Multiline Terminating Systems and Protective Circuitry directly connected to the facilities utilized to provide services under the provisions of this Guide, and which are considered grandfathered under Part 68 of the F.C.C.'s Rules and Regulations.

Host Office

The term "Host Office" denotes an electronic switching system which provides call processing capabilities for one or more Remote Switching Modules or Remote Switching Systems.

ACCESS SERVICE

2. General Regulations (Cont'd)

2.6 Definitions (Cont'd)

Immediately Available Funds

The term "Immediately Available Funds" denotes a corporate or personal check drawn on a bank account and funds which are available for use by the receiving party on the same day on which they are received and include U.S. Federal Reserve bank wire transfers, U.S. Federal Reserve notes (paper cash), U.S. coins, U.S. Postal Money Orders and New York Certificates of Deposit.

Impedance Balance

The term "Impedance Balance" denotes the method of expressing Echo Return Loss and Singing Return Loss at a 4-wire interface whereby the gains and/or loss of the 4 wire portion of the transmission path, including the hybrid, are not included in the specification.

Impulse Noise

The term "Impulse Noise" denotes any momentary occurrence of the noise on a channel over a specified level threshold. It is evaluated by counting the number of occurrences which exceed the threshold.

Individual Case Basis

The term "Individual Case Basis" denotes a condition in which the regulations, if applicable, rates and charges for an offering under the provisions of this Guide are developed based on the circumstances in each case.

Initial Address Message (IAM)

The term "Initial Address Message (IAM)" denotes an SS7 message sent in the forward direction to initiate trunk set up with the busying of an outgoing trunk which carries the information about that trunk along with other information relating to the routing and handling of the call to the next switch.

ACCESS SERVICE

2. General Regulations (Cont'd)

2.6 Definitions (Cont'd)

Inserted Connection Loss

The term "Inserted Connection Loss" denotes the 1004 H2 power difference (in dB) between the maximum power available at the originating end and the actual power reaching the terminating end through the inserted connection.

Interconnection

The term "Interconnection" denotes the termination of a customer's basic transmission facilities, including optical terminating equipment and multiplexers at or near Telephone Company wire center or Telephone Company access tandem. Interconnection may be provided as either physical or virtual.

Interconnection Point

The term "Interconnection Point" denotes physical EIS arrangements as the point where the customer-owned cable facilities connect to the Telephone Company termination equipment. The interconnection point for virtual EIS arrangements is the demarcation between ownership of the cable facilities.

Interexchange Carrier (IC) or Interexchange Common Carrier

The terms "Interexchange Carrier" (IC) or "Interexchange Common Carrier" denotes any individual, partnership, association, joint-stock company, trust, governmental entity or corporation engaged for hire in interstate or foreign communications by wire or radio, between two or more exchanges.

Intermodulation Distortion

The term "Intermodulation Distortion" denotes a measure of the nonlinearity of a channel. It is measured using four tones, and evaluating the ratios (in dB) of the transmitted composite four-tone signal power to the second-order products of the tones (R2), and the third-order products of the tones (R3).

ACCESS SERVICE

2. General Regulations (Cont'd)

2.6 Definitions (Cont'd)

Interstate Communications

The term "Interstate Communications" denotes both interstate and foreign communications.

Intrastate Communications

The term "Intrastate Communications" denotes any communications within a state subject to oversight by a state regulatory commission as provided by the laws of the state involved.

Line Side Connection

The term "Line Side Connection" denotes a connection of a transmission path to the line side of a local exchange switching system.

Local Access and Transport Area

The term "Local Access and Transport Area" (LATA) denotes a geographic area established by the Telephone Company for the provision and administration of its communications service. It encompasses one or more Telephone Company designated exchanges which are configured in relative proximity to one another and may be reconfigured by the Telephone Company in the normal operation of its business. As used herein, the term LATA refers only to these Telephone Company designated exchanges and does not necessarily have any predetermined association with the term LATA used by other exchange carriers.

Logical Channel

The term "Logical Channel" denotes a communication channel which allows two-way simultaneous transmission of data packets through the network. No circuit capability is preassigned to a logical channel. Capacity is made available as the data is transmitted. Each virtual connection utilizes one logical channel.

ACCESS SERVICE

2. General Regulations (Cont'd)

2.6 Definitions (Cont'd)

Loop Around Test Line

The term "Loop Around Test Line" denotes an arrangement utilizing a Telephone Company central office to provide a means to make certain two-way transmission tests on a manual basis. This arrangement has two central office terminations, each reached by means of separate telephone numbers and does not require any specific customer premises equipment. Equipment subject to this test arrangement is at the discretion of the customer.

Loss Deviation

The term "Loss Deviation" denotes the variation of the actual loss from the designed value.

Message

The term "Message" denotes a "call" as defined preceding.

Milliwatt (102 Type) Test Line

The term "Milliwatt (102 Type) Test Line" denotes an arrangement in an end office which provides a 1004 Hz tone at 0 dBm0 for one-way transmission measurements towards the customer's premises from the Telephone Company end office.

Mobile Telephone Switching Office (MTSO)

The term "Mobile Telephone Switching Office (MTSO)" denotes a Cellular Mobile Carrier (CMC) Switching System that is used to originate or terminate calls on the CMC network, or originate or terminate calls between the CMC and the public switched telephone network.

(N)
|
(N)

ACCESS SERVICE

2. General Regulations (Cont'd)

2.6 Definitions (Cont'd)

Network Control Signaling

The term "Network Control Signaling" denotes the transmission of signals used in the telecommunications system which perform functions such as supervision (control, status, and charge signals), address signaling (e.g., dialing), calling and called number identifications, rate of flow, service selection error control and audible tone signals (call progress signals indicating re-order or busy conditions, alerting, coin denominations, coin collect and coin return tones) to control the operation of the telecommunications system.

(M)

(M)

Node

The term "Node" denotes a SONET ring service element that designates either a customer designated location or a Telephone Company wire center location on the SONET ring. It also denotes the location/address of where a channelized service originates or terminates on a ring.

Nonsynchronous Test Line

The term "Nonsynchronous Test Line" denotes an arrangement in step-by-step end offices which provides operational tests which are not as complete as those provided by the synchronous test lines, but can be made more rapidly.

North American Numbering Plan

The term "North American Numbering Plan" denotes a three digit area (Numbering Plan Area) code and a seven-digit telephone number made up of a three-digit Central office code plus a four-digit station number.

Off-hook

The term "off-hook" denotes the active condition of Switched Access or a Telephone Exchange Service Line.

On-hook

The term "On-hook" denotes the idle condition of Switched Access or a Telephone Exchange Service line.

Open Circuit Test Line

The term "Open Circuit Test Line" denotes an arrangement in an end office which provides an ac circuit termination of a trunk or line by means of an inductor of several Henries.

ACCESS SERVICE

2. General Regulations (Cont'd)

2.6 Definitions (Cont'd)

Optical Carrier Rate (OC-N)

The term "OC-N" denotes an Optical Networking transmission signal, speed, line rate, commonly referred to as follows:

<u>OC-N Rate</u>	<u>Bandwidth Capacity</u>
OC-1	51.84 Mbps
OC-3	155.52 Mbps
OC-12	622.08 Mbps
OC-24	1.25 Gbps
OC-48	2.488 Gbps

Originating Direction

The term "Originating Direction" denotes the use of access service for the origination of calls from an End User Premises to an IC Premises.

OZZ Code

The term "OZZ Code" denotes the service class routing code of a multifrequency (MF) call that indicates the interexchange carrier trunk group to which the traffic will be routed (e.g., 0+, 0-, 500, 900, etc.).

Pay Telephone

The term "Pay Telephone" denotes Telephone Company provided instruments and related facilities that are available to the general public for public convenience and necessity, including public and semipublic telephones, and coinless telephones.

Payload

The term "Payload" denotes the portion of the SONET signal available to carry service signals such as DS0, DS1, and DS3.

Phase Jitter

The term "Phase Jitter" denotes the unwanted phase variations of a signal.

ACCESS SERVICE

2. General Regulations (Cont'd)

2.6 Definitions (Cont'd)

Physical EIS

The term "Physical EIS" denotes an offering that enables customers to place equipment needed to terminate basic transmission facilities, including optical terminating equipment and multiplexers, within or upon the Telephone Company's wire center or Telephone Company access tandem buildings, use such equipment to connect customer's fiber optic systems or microwave radio transmission facilities (where reasonably feasible) with the local exchange carrier's equipment and facilities used to provide interstate switched and special access services.

Plant Test Date

The term "Plant Test Date" denotes the date on which installation is completed and the Telephone Company to customer testing can begin.

Point of Termination

The term "Point of Termination" denotes the point of demarcation at a customer-designated premises at which the Telephone Company's responsibility for the provision of Access Service ends.

Premises

The term "Premises" denotes a building or buildings on continuous property (except Railroad Right-of-Way, etc.) not separated by a public highway.

Release Message

The term "Release Message" denotes an SS7 Message sent in either direction to indicate that a specific circuit is being released.

Remote Switching Modules and/or Remote Switching Systems

The term "Remote Switching Modules and/or Remote Switching Systems" denotes remotely controlled electronic end office switches which obtain their call processing capability from an ESS-type Host Office. The Remote Switching Modules and/or Remote Switching Systems cannot accommodate direct trunks to an IC.

ACCESS SERVICE

2. General Regulations (Cont'd)

2.6 Definitions (Cont'd)

Return Loss

The term "Return Loss" denotes a measure of the similarity between the two impedances at the junction of two transmission paths. The higher the return loss, the higher the similarity.

Registered Equipment

The term "Registered Equipment" denotes the customer's premises equipment which complies with and has been approved within the Registration Provisions of Part 68 of the FCC's Rules and Regulations.

Service Control Point

The term "Service Control Point (SCP)" denotes an SS7 network control interface element between the Telephone Company's SS7 network and one or more data bases.

Secure Socket Layer (SSL)

The term "Secure Socket Layer ("SSL)" denotes a security protocol that provides data encryption, server authentication, message integrity, and optional client authentication for a TCP/IP connection.

Service Date

The term "Service Date" denotes the date that the service is made available to the customer. A confirmed ASR is required to establish a service date.

Service Switching Point (SSP)

The term "Service Switching Point" (SSP) denotes a signal point equipped with the ability to halt call process, formulate and send a SS7 query to a remote location and route the call based on information contained in the response.

Serving Wire Center

That Telephone Company designated wire center serving the customer's designated premises and used for mileage measurement to determine local transport or circuit mileage charges for Access Service.

ACCESS SERVICE

2. General Regulations (Cont'd)

2.6 Definitions (Cont'd)

Seven Digit Manual Test Line

The term "Seven Digit Manual Test Line" denotes an arrangement which allows the Customer to select balance, milliwatt and synchronous test lines by manually dialing a seven digit number over the associated access connection.

Shortage of Facilities or Equipment

The term "Shortage of Facilities or Equipment" denotes a condition which occurs when the Telephone Company does not have appropriate cable, switching capacity, bridging or, multiplexing equipment, etc., necessary to provide the Access service requested by the customer.

Short Circuit Test Line

The term "Short Circuit Test Line" denotes an arrangement in an end office which provides for an ac short circuit termination of a trunk or line by means of a capacitor of at least four microfarads.

Signal-to-C-Notched Noise Ratio

The Term "Signal-to-C-Notched Noise Ratio" denotes the ratio in dB of a test signal to the corresponding C-Notched Noise.

Signaling Point

The term "Signaling Point (SP)" denotes an SS7 network interface element capable of originating and/or terminating SS7 messages.

Signaling System 7 (SS7)

The term "Signaling System 7 (SS7)" denotes the layered protocol used for standardized common channel signaling in the United States.

ACCESS SERVICE

2. General Regulations (Cont'd)

2.6 Definitions (Cont'd)

Signal Transfer Point (STP)

The term "Signal Transfer Point (STP)" denotes a packet switch which provides access to the Telephone Company's SS7 network and performs SS7 message signal routing and screening. The technical interface specifications, transmission specifications, and diversity requirements for interconnecting to the Telephone Company's SS7 network at the STP are as described in Technical Reference GR-905-CORE, Issue 11.

Signal Transfer Point (STP) Port

The term "Signal Transfer Point (STP) Port" denotes the physical point of termination and interconnection to the STP.

Singing Return Loss

The term "Singing Return Loss" denotes the frequency weighted measure of return loss at the edges of the voiceband (200 to 500 Hz and 2500 to 3200 Hz), where singing (instability) problems are most likely to occur.

SONET

The term "SONET" (Synchronous Optical Network) denotes a family of fiber optic transmission bit rates starting at 51.84 Mbps, designed to provide the flexibility needed to transport many digital signals with different capacities.

Statistical Multiplexing

The term "Statistical Multiplexing" denotes a technique in which timeslots are dynamically allocated on the basis of need rather than being predetermined. The data is typically transmitted on a first come, first served basis.

Subtending End Office of the Telephone Company Access Tandem

The term "Subtending End Office of the Telephone Company Access Tandem" denotes an end office that has final trunk group routing through the Telephone Company access tandem.

ACCESS SERVICE

2. General Regulations (Cont'd)

2.6 Definitions (Cont'd)

Synchronous Test Line

The term "Synchronous Test Line" denotes an arrangement in an end office which performs marginal operational tests of supervisory and ring-tripping functions equivalent information needed to perform tandem switching functions.

Synchronous Transport Signal (STS)

STS-1 has the capacity to transport up to twenty-eight (28) DS1s or one (1) DS3.

Synchronous Transport Signal (STS1)

The term "Synchronous Transport Signal" (STS1) denotes a 51.84 Mbps signal that is the electrical equivalent of the OC1 or a DS3 with additional Mbps devoted to SONET overhead information. An STS1 can carry a DS3 or 28 DS1s when specifically formatted (mapped). These DS1s may be accessed off-ring using DS3 to DS1 Multiplexing as set forth in Section 20 or at an enhanced node via a DS3 Transmux port.

Terminating Direction

The term "Terminating Direction" denotes the use of Access Service for the completion of calls from an IC premises to an End User Premises.

Toll Free

"Toll Free" is considered to mean any access service which utilizes any of the following NPAs: 800, 888, 877, 866, 855, 844, 833, and 822 as they become available to the industry.

Transmission Measuring (105 Type) Test Line/Responder

The term "Transmission Measuring (105 Type) Test Line/Responder" denotes an arrangement in an end office which provides far-end access to a responder and permits two-way loss and noise measurements to be made on trunks from a near end office.

ACCESS SERVICE

2. General Regulations (Cont'd)

2.6 Definitions (Cont'd)

Transmission Path

The term "Transmission Path" denotes an electrical path capable of transmitting signals within the range of the service offering, e.g., a voice grade transmission path is capable of transmitting voice frequencies within the approximate range of 300 to 3000 Hz. A transmission path is comprised of physical or derived facilities consisting of any form or configuration of plant typically used in the telecommunications industry.

Transmuxing

The term "Transmuxing" denotes the function of a DSR DS3 Transmux port which performs a DS3 to DS1 conversion at a DSR node. The DS3 to DS1 conversions allows a single DSR DS3 Transmux port to be associated with up to twenty-eight (28) VT1.5 mapped DSR DS1 ports. Transmuxing within the DSR network retains DS1 visibility allowing for full, proactive maintenance capability of DS1 signals.

Trunk

The term "Trunk" denotes a communications path connecting two switching systems in a network, used in the establishment of an end-to-end connection.

Trunk Group

The term "Trunk Group" denotes a set of trunks which are traffic engineered as a unit for the establishment of connections between switching systems in which all of the communications paths are interchangeable.

Trunk Side Connection

The term "Trunk Side Connection" denotes the connection of a transmission path to the trunk side of a local exchange switching system.

Two-Wire to Four-Wire Conversion

The term "Two-Wire to Four-Wire Conversion" denotes an arrangement which converts a four-wire transmission path to a two-wire transmission path to allow a four-wire facility to terminate to a two-wire entity (e.g., a central office switch).

ACCESS SERVICE

2. General Regulations (Cont'd)

2.6 Definitions (Cont'd)

Uniform Service Order Code

The term "Uniform Service Order Code" denotes a three or five character alphabetic, numeric, or an alphanumeric code that identifies a specific item of service or equipment. Uniform Service Order Codes are used in the Telephone Company billing system to generate recurring rates and nonrecurring charges.

V&H Coordinates

The term "V and H Coordinates Method" denotes a method of computing airline miles between two points by utilizing an established formula which is based on the vertical and horizontal coordinates of the two points.

Virtual EIS

The term "Virtual EIS" denotes an offering that enables customers to designate or specify equipment needed to terminate basic transmission facilities, including optical terminating equipment and multiplexers, to be located within or upon the Telephone Company's wire center or Telephone Company's access tandem buildings, and dedicated to such customer's use.

WATS Serving Office

"WATS Serving Office" denotes a Telephone Company switching office capable of performing the optional screening functions used in Combined Access Service Arrangements.

Wire Center

The term "Wire Center" denotes a building in which one or more central offices, including end office switches, used for the provision of Telephone Exchange Services, are located.

ACCESS SERVICE

2. General Regulations (Cont'd)

2.7 Service Level Agreements

2.7.1 Basic Service Level Agreements (Basic SLAs)

Regulations pertaining to Basic SLAs are contained in this Guide as specified following:

<u>Description</u>	<u>Reference</u>
Credit Allowance for Service Interruptions	2.7.1.1

(D)

ACCESS SERVICE

2. General Regulations (Cont'd)

2.7 Service Level Agreements (Cont'd)

2.7.1 Basic Service Level Agreements (Basic SLAs) (Cont'd)

2.7.1.1 Credit Allowance for Service Interruption

(A) General

A service is interrupted when it becomes unusable to the customer because of failure of a facility component used to furnish service under this Guide or in the event that the protective controls applied by the Telephone Company result in the complete loss of service by the customer as set forth in 6.4(A) following. An interruption period starts when an inoperative service is reported by the customer to the Telephone Company and ends when the service is operative. The customer is responsible for sectionalizing trouble to the Telephone Company facilities and/or equipment as set forth in 2.3.10 preceding.

Subject to Section 2.7.4(B) following, in case of an interruption to any service, credit allowance for the period of interruption shall be calculated as set forth in this Section 2.7.1.1.

The credit allowance for an interruption or for a series of interruptions shall not exceed the monthly rate and minimum monthly usage charge for the service interrupted in any one monthly billing period.

For purposes of this section of the tariff, "major fraction" is defined as that time period representing one-half or more of the incremental time period used to apply the credit allowance for those specific services listed in (B) following.

Service interruptions for Specialized Service or Arrangements provided under the provisions of 12 following shall be administered in the same manner as those set forth in this Section 2.7.1.1 unless other regulations are specified with the individual case filing.

ACCESS SERVICE

- 2. General Regulations (Cont'd)
 - 2.7 Service Level Agreements (Cont'd)
 - 2.7.1 Basic Service Level Agreements (Basic SLAs) (Cont'd)
 - 2.7.1.1 Credit Allowance for Service Interruption (Cont'd)
 - (A) General (Cont'd)
 - (1) An out of service credit will apply for the following Optical Networking rate elements, where applicable, should the service be interrupted due to the Telephone Company's system's failure to switch to protected electronics and/or facilities within one (1) second in those locations connected to the Telephone Company surveillance system unless such interruptions are a result of conditions outside the Telephone Company's control:
 - ON-net Banded Optical Transport provisioned via a ring topology
 - (2) Credit will be predicated on information provided by the Telephone Company's and the customer's network surveillance systems associated with this service arrangement. The Telephone Company and the customer shall each have the opportunity to perform an annual inspection of the other party's network surveillance system to confirm its accuracy. The out-of-service credit will be calculated based on the monthly rate element charges of that portion of the inter-office network rendered inoperative. A maximum limit of one month recurring charge per rate element will be allotted for a interruption or series of interruptions within any one billing period.
 - (3)
 - (4)
 - (5)
 - (6)
 - (7) For Dedicated SONET Entrance Facilities, any single service outage of one (1) hour or more and due solely to a Telephone Company facility failure will result in a credit of one hundred percent (100%) of the monthly rate for the applicable DSEF rate elements affected. Only one such credit is allowed in a single month's billing period.
 - (8) The credit allowance for all other Optical Networking access services will be as shown in 2.7.1.1(B).

ACCESS SERVICE

2. General Regulations (Cont'd)

2.7 Service Level Agreements (Cont'd)

2.7.1 Basic Service Level Agreements (Basic SLAs) (Cont'd)

2.7.1.1 Credit Allowance for Service Interruption (Cont'd)

(B) Special Access Services

- (1) For Special Access Services (other than Program Audio and Video Digital Transport Service TV-1 Analog/ Services) and Multiplexing services, no credit shall be allowed for an interruption of less than 30 minutes. The customer shall be credited for an interruption of 30 minutes or more at the rate of 1/1440 of the monthly charges for the facility or service for each period of 30 minutes or major fraction thereof that the interruption continues.

The monthly charges used to determine the credit shall be as follows:

- (a) For two point services, the monthly charge subject to credit shall be the total of all the monthly rate element charges associated with the service (i.e., two circuit terminations, circuit mileage and optional features and functions).
- (b) For multipoint services, the monthly charge subject to credit shall be only the total of all the monthly rate element charges associated with that portion of the service that is inoperative (i.e., a circuit termination per customer premises, circuit mileage and optional features and functions).
- (c) For multiplexed services, the monthly charge subject to credit shall be the total of all the monthly rate element charges associated with that portion of the service that is inoperative. When the facility which is multiplexed or the multiplexer itself is inoperative, the monthly charge shall be the total of all the monthly rate element charges associated with the service (i.e., the circuit termination, circuit mileage and optional features and functions, including the multiplexer on the facility to the hub, and the circuit terminations, circuit mileage and optional features and functions on the individual services from the hub). When the service which rides a circuit of the multiplexed facility is inoperative, the monthly charge shall be the total of all the monthly rate element charges associated with that portion of the service from the Hub to a customer premises (i.e., circuit termination, circuit mileage and optional features and functions).

ACCESS SERVICE

2. General Regulations (Cont'd)

2.7 Service Level Agreements (Cont'd)

2.7.1 Basic Service Level Agreements (Basic SLAs) (Cont'd)

2.7.1.1 Credit Allowance for Service Interruption (Cont'd)

(B) Special Access Services (Cont'd)

(2) For Program Audio and Video Digital Transport Service TV-1 Analog Special Access Services, no credit shall be allowed for an interruption of less than 30 seconds. The customer shall be credited for an interruption of 30 seconds or more as follows:

(a) For two-point services, when monthly rates are applicable, the credit shall be at the rate of 1/8640 of the monthly charges for the service for each period of 5 minutes or major fraction thereof that the interruption continues.

(b) For two-point services, when daily rates are applicable, the credit shall be at the rate of 1/288 of the daily charges for the service for each period of 5 minutes or major fraction thereof that the interruption continues.

(c) For multipoint services, when monthly rates are applicable, the credit shall be at the rate of 1/8640 of the monthly charges for each circuit termination, circuit mileage and optional features and functions that is inoperative for each period of 5 minutes or major fraction thereof that the interruption continues.

(d) For multipoint services, when daily rates are applicable, the credit shall be at the daily rate of 1/288 of the daily charges for each circuit termination, circuit mileage and optional features and functions that is inoperative for each period of 5 minutes or major fraction thereof that the interruption continues.

(e) For multipoint services, the credit for the monthly or daily charges includes the charges for the distribution amplifier only when the distribution amplifier is inoperative.

(f) When two or more interruptions occur during a period of 5 consecutive minutes, such multiple interruptions shall be considered as one interruption.

ACCESS SERVICE

2. General Regulations (Cont'd)

2.7 Service Level Agreements (Cont'd)

2.7.1 Basic Service Level Agreements (Basic SLAs) (Cont'd)

2.7.1.1 Credit Allowance for Service Interruption (Cont'd)

(B) Special Access Services (Cont'd)

(3) For certain Special Access services (Digital Data Access, DA1-4; and High Capacity, HC1), any period during which the error performance is below that specified for the service will be considered as an interruption.

(4) Except as noted, all Special Access Services will be eligible for a credit allowance for each occurrence of a service interruption period greater than 30 minutes. The maximum credit allowance will be \$200.00 for each out of service condition within the Telephone Company's facilities and will not exceed the monthly charge for the interrupted service. The credit allowance will not be applied more than once per calendar month. This credit allowance is applicable in all jurisdictions. The credit allowance is in addition to the credit allowance in 2.7.1.1(B)(1). A credit allowance will not be extended in accordance with conditions in 2.1.3 and 2.7.4(B) for repair of Telephone Company owned facilities.

The exceptions to this credit allowance are Program Audio Service - Daily Rates in 7.6.5, Digital Video Transport Service TV-1 Analog Services in 7.7, Individual Case Basis Services in 7.12 and Specialized Service Arrangements in 12.

* Section 2.7.1.1(B)(4) is not available for Special Access Services installed after June 1, 2006. The preceding sentence applies to both Special Access Services that are provided on a month-to-month basis and Special Access Services that are provided under a Discount Plan (as defined below).

ACCESS SERVICE

2. General Regulations (Cont'd)

2.7 Service Level Agreements (Cont'd)

2.7.1 Basic Service Level Agreements (Basic SLAs) (Cont'd)

2.7.1.1 Credit Allowance for Service Interruption (Cont'd)

(B) Special Access Services (Cont'd)

(4) (Cont'd)

For Special Access Services installed on or before June 1, 2006, Section 2.7.1.1(B)(4) will not be available as follows:

- (a) For Special Access Services provided on a month-to-month basis, after June 1, 2006.
- (b) For Special Access Services provided under a Discount Plan (as defined below), after the date of expiration, termination, or cancellation of the Discount Plan commitment period that is in effect on June 1, 2006.
- (c) For Special Access Services provided under a Discount Plan (as defined below) that are covered by a National Service Level Agreement Plan, during the period that a customer participates in such National Service Level Agreement Plan. The customer has the option to subscribe to National Service Level Agreement Plans as set forth in Section 2.7.3 and/or Section 7.2.8 following. Nothing in this paragraph (c) shall in any way limit the effect of paragraph (b) preceding.

As used in this note, "Discount Plan" means any tariff arrangement for the provision of Special Access Services other than on a month-to-month basis.

For any month for which a Special Access Service receives a credit allowance under Section 2.7.1.1(B)(4), that Special Access Service shall not receive a credit allowance under Section 2.7.1.1(B)(5).

ACCESS SERVICE

2. General Regulations (Cont'd)

2.7 Service Level Agreements (Cont'd)

2.7.1 Basic Service Level Agreements (Basic SLAs) (Cont'd)

2.7.1.1 Credit Allowance for Service Interruption (Cont'd)

(B) Special Access Services (Cont'd)

- (5) For certain Special Access services, a Special Access Service Guarantee (SASG) credit allowance will apply in the event that such services experience a service interruption of four (4) or more consecutive hours except as specified in 2.7.4(B) following. The SASG credit allowance will apply to Voice Grade, monthly Program Audio and Video Digital Transport Service TV-1 Analog, Digital Data Service (DDS), and High Capacity DS1 (excluding the portion of a DS1 service that is derived at a customer designated premises using a DS3 Premises Multiplexer) & DS3 Special Access services (collectively, Special Access Services).

The customer has the option to subscribe to National SLA Plans as set forth in Section 2.7.3 and/or Section 7.2.8 following. When a customer subscribes to a National SLA Plan, credit allowances under this Section 2.7.1.1(B)(5) do not apply to services covered by the National SLA Plan.

If a Special Access Service is eligible for an SASG credit allowance, the Telephone Company shall provide the applicable credit amount as set forth in the table following. The Telephone Company shall bill customer the applicable monthly rate for the Special Access Service, and if customer is eligible to receive the SASG credit allowance, customer shall receive the SASG credit in a later invoice. Except as stated in this Guide, the SASG credit allowance is in addition to any other credit allowances available under this Section 2.7.1.1. The maximum amount of all credit allowances available under this Section 2.7.1.1 for a Special Access Service for a given billing period shall not exceed the total applicable monthly charge paid by the customer for such Special Access Service. The monthly charge will consist of all applicable rate elements charged to the circuit experiencing the service interruption. The SASG credit allowance can only be applied once per month on a per circuit basis. For multi-point circuits, the SASG credit allowance will apply to each leg of the circuit that experiences a service interruption.

ACCESS SERVICE

2. General Regulations (Cont'd)

2.7 Service Level Agreements (Cont'd)

2.7.1 Basic Service Level Agreements (Basic SLAs) (Cont'd)

2.7.1.1 Credit Allowance for Service Interruption (Cont'd)

(B) Special Access Services (Cont'd)

(5) (Cont'd)

The SASG credit allowance for each applicable service is listed below and applies to all states:

<u>Service</u>	<u>SASG (per circuit)</u>
Voice Grade	20.00
Program Audio (monthly, full –time only)	
200 – 3500 Hz	10.00
100 – 5000 Hz	15.00
50 – 8000 Hz	20.00
50 – 15000 Hz	25.00
Video Digital Transport Service	
TV-1 Analog (monthly)	100.00
Digital Data Service (DDS)	
2.4 kbps	40.00
4.8 kbps	45.00
9.6 kbps	50.00
19.2 kbps	55.00
56.0 kbps	60.00
64.0 kbps	65.00
High Capacity	
DS1	160.00
DS3	400.00

ACCESS SERVICE

2. General Regulations (Cont'd)

2.7 Service Level Agreements (Cont'd)

2.7.1 Basic Service Level Agreements (Basic SLAs) (Cont'd)

2.7.1.1 Credit Allowance for Service Interruption (Cont'd)

(C) Reserved for Future Use

ACCESS SERVICE

- 2. General Regulations (Cont'd)
 - 2.7 Service Level Agreements (Cont'd)
 - 2.7.1 Basic Service Level Agreements (Basic SLAs) (Cont'd)
 - 2.7.1.1 Credit Allowance for Service Interruption (Cont'd)

ACCESS SERVICE

2. General Regulations (Cont'd)

2.7 Service Level Agreements (Cont'd)

2.7.1 Basic Service Level Agreements (Basic SLAs) (Cont'd)

2.7.1.1 Credit Allowance for Service Interruption (Cont'd)

(D) When a Credit Allowance Does Not Apply

Services will not be eligible for credits when any of the conditions set forth in Section 2.7.4(B) following exist.

(E) Use of an Alternative Service Provided by the Telephone Company

Should the customer elect to use an alternative service provided by the Telephone Company during the period that a service is interrupted, the customer must pay the tariffed rates and charges for the alternative service used.

(F) Temporary Surrender of a Service

In certain instances, the customer may be requested by the Telephone Company to surrender a service for purposes other than maintenance, testing or activity relating to a service order. If the customer consents, a credit allowance will be granted. The credit allowance will be 1/440 of the monthly rate for each period of 30 minutes or fraction thereof that the service is surrendered. In no case will the credit allowance exceed the monthly rate for the service surrendered in any one monthly billing period.

ACCESS SERVICE

2. General Regulations (Cont'd)

2.7 Service Level Agreements (Cont'd)

2.7.1 Basic Service Level Agreements (Basic SLAs) (Cont'd)

2.7.1.2 Reserved For Future Use

(C)

ACCESS SERVICE

2. General Regulations (Cont'd)

2.7 Service Level Agreements (Cont'd)

2.7.2 Enhanced Service Level Agreements (Enhanced SLAs)

Regulations pertaining to Enhanced SLAs are contained in this Guide as specified following:

<u>Description</u>	<u>Tariff Reference</u>
Integrated Optical Service Rider SLAs	2.7.2.1

ACCESS SERVICE

2. General Regulations (Cont'd)

2.7 Service Level Agreements (Cont'd)

2.7.2 Enhanced Service Level Agreements (Enhanced SLAs) (Cont'd)

2.7.2.1 Integrated Optical Service Rider SLAs

(A) General

- (1) With the exception of those Integrated Optical Service Riders provided subject to Section 23.1.3 following, the SLAs set forth in this Section 2.7.2.1 apply to all other Integrated Optical Service Riders set forth in Section 23.1 following ("Qualifying Services").
- (2) The monthly recurring rate(s) for the Qualifying Service are the Integrated Optical Service Rider Appearances.
- (3) To receive credit, the Telephone Company must receive from the customer a written request for credit within sixty (60) calendar days of the end of the calendar month in which the SLA threshold was missed. The customer's request for credit must be submitted to the appropriate Telephone Company in a manner mutually agreed upon by the Telephone Company and the customer. The request must include a list of the identification numbers of all impacted circuits.

(B) Availability

- (1) Availability refers to the percentage of time over a calendar month that a Qualifying Service is able to transmit data over the Telephone Company's integrated optical service. A Qualifying Service is unavailable if data cannot be transmitted because of a failure of a facility component within the Telephone Company's integrated optical service that is used to furnish the Qualifying Service provided under this Tariff.
- (2) Availability is calculated as follows: $\text{Availability} = \frac{(1440 \times \text{Number of Days in Month}) - (\text{Number of Minutes the Service is unavailable during Month})}{(1440 \times \text{Number of Days in Month})}$. The number of minutes the Service is unavailable is as determined by the Telephone Company.

ACCESS SERVICE

2. General Regulations (Cont'd)

2.7 Service Level Agreements (Cont'd)

2.7.2 Enhanced Service Level Agreements (Enhanced SLAs) (Cont'd)

2.7.2.1 Integrated Optical Service Rider SLAs (Cont'd)

(B) Availability (Cont'd)

- (3) The Telephone Company threshold for Availability under this Section in a calendar month is 99.999%.
- (4) If Availability under this Section is less than the threshold, then a credit equal to twenty-five percent (25%) of the monthly recurring rate(s) for the affected Qualifying Service applies. Only one (1) such credit is allowed in a single month's billing period.

(C) Mean Time to Restore (MTTR)

- (1) MTTR applies to an interruption of service that is within the Telephone Company's integrated optical service.
- (2) Interruption of service is defined as a condition which renders a Qualifying Service unusable to the customer (i.e., data cannot be transmitted) because of a failure of a facility within the Telephone Company's integrated optical service that is used to furnish the Qualifying Service under this Guide. The Telephone Company will initiate a trouble ticket on all DS1 Qualifying Service interruptions reported by the customer. The Telephone Company will initiate a trouble ticket on all DS3 Qualifying Service interruptions reported by the customer and/ or detected by the Telephone Company's network.

ACCESS SERVICE

2. General Regulations (Cont'd)

2.7 Service Level Agreements (Cont'd)

2.7.2 Enhanced Service Level Agreements (Enhanced SLAs) (Cont'd)

2.7.2.1 Integrated Optical Service Rider SLAs (Cont'd)

(C) Mean Time to Restore (MTTR) (Cont'd)

(3) MTTR for a calendar month shall be the average of all Time to Restore (TTR), as calculated by the Telephone Company. The TTR is the period of time the Qualifying Service is unavailable between the opening and closing of the trouble ticket, minus any stop clock time that was logged against the trouble ticket. Stop clock time includes, by way of example, the following times:

- Periods when customer testing is occurring.
- Periods when the customer is working on its own Customer Premises Equipment (CPE) and has not yet released the Qualifying Service to the Telephone Company for maintenance, testing or repair.
- Periods when the Telephone Company is awaiting customer authorization to commence work on the Qualifying Service.
- Periods when the Telephone Company is denied access to premises or facilities necessary to diagnose, repair, or test a Qualifying Service.
- Periods following repair of the Qualifying Service when the ticket is held open by the customer to ensure the trouble is resolved.

(4) MTTR is calculated by summing TTR for all measured tickets for the customer for the calendar month and dividing by the total number of tickets for that customer during that month.

(5) MTTR excludes any subsequent reports (i.e., additional customer inquiries while the trouble is pending), CPE troubles, trouble found on the customer's side of the point of demarcation, no trouble found, troubles closed due to customer action, force majeure events, and troubles repaired by the Telephone Company prior to receipt of a trouble report on that Qualifying Service.

ACCESS SERVICE

2. General Regulations (Cont'd)

2.7 Service Level Agreements (Cont'd)

2.7.2 Enhanced Service Level Agreements (Enhanced SLAs) (Cont'd)

2.7.2.1 Integrated Optical Service Rider SLAs (Cont'd)

(C) Mean Time to Restore (MTTR) (Cont'd)

(6) The threshold for MTTR in a calendar month is 2.5 hours for Qualifying Services.

(7) If the MTTR is greater than 2.5 hours over the calendar month for all of customer's Qualifying Services, then a credit equal to twenty-five percent (25%) of the monthly recurring rate(s) for the affected Qualifying Service applies for those Qualifying Services that were the subject of a trouble ticket during the measured calendar month whose TTR exceeded 2.5 hours. Only one (1) such credit is allowed in a single month's billing period. If the MTTR is 2.5 hours or less on all of customer's Qualifying Services, then no credit applies to any Qualifying Service, even if the TTR on a particular Qualifying Service exceeded such threshold.

(D) Qualifying Services will not be included in threshold measurements under this Section 2.7.2.1 and will not be eligible for credits under this Section 2.7.2.1 when any of the conditions set forth in Section 2.7.4(B) following exist.

ACCESS SERVICE

- 2. General Regulations (Cont'd)
 - 2.7 Service Level Agreements (Cont'd)
 - 2.7.3 RESERVED

ACCESS SERVICE

2. General Regulations (Cont'd)

2.7 Service Level Agreements (Cont'd)

2.7.4 When a Credit Allowance Does Not Apply

(A) Performance Commitment Program/On Time Provisioning

This Section 2.7.4(A) applies to and supplements Section 2.7.1.2(A) preceding, Performance Commitment Program – Provisioning; and Section 2.7.2 preceding, Enhanced Service Level Agreements. Services will not be included in performance measurements and credits will not apply, when:

- (1) Provision of service is delayed or prevented due to the acts or omissions of the customer or a party authorized by the customer to use the service; or
- (2) Provision of service is delayed or prevented due to failures in power, equipment, service, or systems provided by the customer or by persons other than the Telephone Company; or
- (3) The customer's premises is inaccessible; or
- (4) The customer changes the order after receiving the confirmed Due Date from the Telephone Company; or
- (5) The customer changes its interface requirements; or
- (6) The customer is not ready to accept service; or
- (7) Independent Telephone Companies are involved in the service installation; or
- (8) Building facilities are not ready (includes space, cable support structures, building risers, and entrance facilities to be provided by persons other than the Telephone Company); or
- (9) The customer orders termination beyond the Network Interface; or
- (10) The installation requires special construction; or
- (11) The customer requests Specialized Service or Arrangements as set forth in Section 12 following or services for which rates were developed on an Individual Case Basis (ICB); or

ACCESS SERVICE

2. General Regulations (Cont'd)

2.7 Service Level Agreements (Cont'd)

2.7.4 When a Credit Allowance Does Not Apply (Cont'd)

(A) Performance Commitment Program/On Time Provisioning (Cont'd)

- (12) The order is for Service Rearrangements or Moves as described in Section 7.2.1(D)(3) and Section 7.2.1(D)(4) following, respectively; or
- (13) Provision of service is delayed or prevented due to the Telephone Company's provision of Telecommunications Service Priority (TSP) System as described in Section 8.8 following; or
- (14) A delay or failure in the provision of service is required, permitted or excused by this Tariff; or
- (15) Provision of service is delayed or prevented due to acts of God or the public enemy, compliance with any law or any regulation or order of any governmental authority, acts of terrorism, war, rebellion, insurrection or sabotage or damage resulting there from, fires, floods, earthquakes, volcanic action, unusually severe weather, explosions, washouts, rules and regulations with regard to common carriers, accidents, epidemics, riots, strikes or other concerted acts of employees, whether direct or indirect, lockouts or other industrial disturbances, whether direct or indirect, worms, viruses or other contaminants that may cause damage to or disable software, computer or electronic systems, or any similar cause, or other causes beyond the Telephone Company's reasonable control; or
- (16) The order is for Expanded Interconnection Services as described in Section 17 following; or

ACCESS SERVICE

2. General Regulations (Cont'd)

2.7 Service Level Agreements (Cont'd)

2.7.4 When a Credit Allowance Does Not Apply (Cont'd)

(B) Credit Allowance for Interruptions/Mean Time to Restore/Availability

This Section 2.7.4(B) applies to and supplements Section 2.7.1.1 preceding, Credit Allowance for Service Interruptions; Section 2.7.2 preceding, Enhanced Service Level Agreements; and Section 2.7.3 preceding, National Service Level Agreements. Services will not be included in performance measurements and credits will not apply:

- (1) When the customer fails to report the interruption to the Telephone Company (excluding DS3 Integrated Optical Service Riders); or
- (2) When the interruption was caused by the act or omission of the customer or a party authorized by the customer to use the service; or
- (3) When the interruption was due to the failure of power, equipment, service, or systems provided by the customer or persons other than the Telephone Company; or
- (4) For any period in which the Telephone Company is not afforded access to the premises where the service is terminated; or
- (5) When the customer has released the service to the Telephone Company for maintenance purposes, to make rearrangements, or for the implementation of an order for a change in the service, during the time that was negotiated with the customer prior to the release of that service (thereafter, a credit allowance as set forth in this Section 2.7 applies); or
- (6) For any period of scheduled maintenance or scheduled downtime where the customer has received prior notification from the Telephone Company; or
- (7) When interruptions occur or continue because of the failure of the customer to authorize the replacement of any element of special construction; or

ACCESS SERVICE

2. General Regulations (Cont'd)

2.7 Service Level Agreements (Cont'd)

2.7.4 When a Credit Allowance Does Not Apply (Cont'd)

(B) Credit Allowance for Interruptions/Mean Time to Restore/Availability
(Cont'd)

- (8) For periods when the customer elects not to release the service for testing and/or repair; or
- (9) For periods of temporary discontinuance as set forth in Section 2.1.8 preceding; or
- (10) During periods of interruption as set forth in Section 8.3 following; or
- (11) When an interruption is required, permitted or excused by this Tariff, or
- (12) For interruptions, failures or delays due to acts of God or the public enemy, compliance with any law or any regulation or order of any governmental authority, acts of terrorism, war, rebellion, insurrection or sabotage or damage resulting there from, fires, floods, earthquakes, volcanic action, unusually severe weather, explosions, washouts, rules and regulations with regard to common carriers, accidents, epidemics, riots, strikes or other concerted acts of employees, whether direct or indirect, lockouts or other industrial disturbances, whether direct or indirect, worms, viruses or other contaminants that may cause damage to or disable software, computer or electronic systems, or any similar cause, or other causes beyond the Telephone Company's reasonable control (except that, this Section 2.7.4(B)(12) does not apply to Section 2.7.1.1, excluding the SASG as set forth in Section 2.7.1.1(B)(5), to which this Section 2.7.4(B)(12) shall apply); or
- (13) For an interruption, or a group of interruptions resulting from a common cause, for amounts less than one dollar.

ACCESS SERVICE

2. General Regulations (Cont'd)

2.8 Sale or Transfer of an Operating Telephone Company's Assets and/or Stock to an Unaffiliated Third Party

This Section 2.8 shall apply: (i) if the Telephone Company sells or transfers all or a portion of the assets or stock of a Frontier Operating Telephone Company (e.g., Frontier California Inc.) to an unaffiliated third party ("Transfer"); and (ii) a service offering or Service Level Agreement (SLA) of this Guide as referenced in this Section 2.8 does not include terms and conditions relating to a Transfer.

2.8.1 General

The terms and conditions set forth in Section 2.8.2 following shall apply:

- (A) when a customer subscribes to a service offering under this Guide that aggregates the customer's purchases from the Telephone Company to measure compliance with such service offering or the customer participates in a SLA that aggregates the customer's measured transactions, and:
- (B) the service offering or SLA does not include terms and conditions pertaining to a Transfer; and
- (C) as a result of the Transfer, one or more of the following conditions occur solely as a result of the Telephone Company no longer providing the same quantity of services:
 - (1) the customer no longer satisfies the minimum requirements of the service offering or SLA;
 - (2) the customer is subject to a related penalty, termination liability or cancellation;
 - (3) the customer is subject to a change in the tier of a volume table or a rate table; and
 - (4) the customer is subject to a change in the rate level of the service offering.

ACCESS SERVICE

2. General Regulations (Cont'd)

2.8 Sale or Transfer of an Operating Telephone Company's Assets and/or Stock to an Unaffiliated Third Party (Cont'd)

2.8.2 Undertaking of the Telephone Company Following a Transfer

When the conditions set forth in 2.8.1 preceding exist, the Telephone Company will utilize the following terms and conditions, as applicable.

(A) If the service offering includes specific minimum ordering requirements for participation, or requires that the customer achieve a minimum number of services, minimum number of rate elements, and/or minimum revenue within a specific geographic area in order to continue its subscription to the service offering or participation in a pricing plan for such service offering (each, a Minimum Requirement), the Telephone Company will apply the terms and conditions of this Section 2.8.2(A). The following service offerings have Minimum Requirements that are subject to this Section 2.8.2(A).

- Call Management Signaling Service as set forth in Section 8.17.4(B) following
- Banded Optical Transport as set forth in Sections 10.6.1(G) and 20(D)(2)(f) following
- TCP/IP Data Aggregation Service as set forth in Section 18.3 following

In the event of a Transfer, the following applies.

- (1) The Telephone Company will, consistent with the service offering, determine if the customer satisfies the Minimum Requirement for the service offering with the reduced quantity of services the Telephone Company provides to the customer following the Transfer; and

ACCESS SERVICE

2. General Regulations (Cont'd)

2.8 Sale or Transfer of an Operating Telephone Company's Assets and/or Stock to an Unaffiliated Third Party (Cont'd)

2.8.2 Undertaking of the Telephone Company Following a Transfer (Cont'd)

(A) (Cont'd)

- (2) if the customer does not satisfy the Minimum Requirement following the Transfer, determine if the customer would have satisfied the Minimum Requirement had the Transfer not occurred. If the customer would have satisfied the Minimum Requirement had the Transfer not occurred, then no further action shall be taken and the customer will be considered to have satisfied the Minimum Requirement. If the customer would not have satisfied the Minimum Requirement had the Transfer not occurred, then the terms and conditions for such result shall apply under the applicable service offering, except that the calculation of any penalty associated with not satisfying the Minimum Requirement shall be reduced pro-rata to reflect the Transfer. Upon renewal of the customer's commitment period for such service offering or subsequent subscription to such service offering, as applicable, the terms and conditions set forth in the applicable section(s) of this Guide shall apply, including satisfying the Minimum Requirement for such service offering using only the quantity of services the customer purchases from the Telephone Company at the time of renewal or subsequent subscription.

ACCESS SERVICE

2. General Regulations (Cont'd)

2.8 Sale or Transfer of an Operating Telephone Company's Assets and/or Stock to an Unaffiliated Third Party (Cont'd)

2.8.2 Undertaking of the Telephone Company Following a Transfer (Cont'd)

(A) (Cont'd)

(2) (Cont'd)

For example, assume Frontier California Inc. transfers a portion of its assets to an unaffiliated third party. Further assume that a customer subscribes to Call Management Signaling Service under Section 8.17.4(B) following which has a minimum monthly billing of one million (1,000,000) call signals per month. Also assume that following the Transfer, the volume of call signals recorded for the customer at the next scheduled review is nine hundred fifty thousand (950,000), and that an estimated one hundred thousand (100,000) call signals were associated with the services transferred to the unaffiliated third party. In this case, the Telephone Company would determine if the customer would have satisfied the minimum number of call signals had the Transfer not occurred by adding (i) the estimated number of call signals associated with the services transferred to the unaffiliated third party and; (ii) the recorded number of call signals for the period of review [950,000 + 100,000 = 1,050,000 call signals]. Based on this calculation, the customer would have satisfied the Minimum Requirement and will not incur any shortfall charges. However, if the result of such calculation was that the customer still did not satisfy the Minimum Requirement for the service, then the terms and conditions for such result shall apply under Section 8.17.4(B) following, except that the calculation of shortfall charges shall be reduced pro-rata to reflect the Transfer.

ACCESS SERVICE

2. General Regulations (Cont'd)

2.8 Sale or Transfer of an Operating Telephone Company's Assets and/or Stock to an Unaffiliated Third Party (Cont'd)

2.8.2 Undertaking of the Telephone Company Following a Transfer (Cont'd)

(B) If the service offering requires that the customer commit a minimum number of the services or rate elements that the customer purchases from the Telephone Company and maintain such minimum during the term of the service offering (a Commitment Level), and the service offering does not apply rates or credits based on a volume based tier structure, the Telephone Company will apply this Section 2.8.2(B). The following service offering has a Commitment Level that is subject to this Section 2.8.2(B).

- DS1 Term Payment Plan as set forth in Section 7.2.1(G) following

In the event of a Transfer, the following applies.

- (1) The Telephone Company will recalculate the Commitment Level for the duration of the current term to reflect the removal of the services the Telephone Company no longer provides to the customer solely as a result of the Transfer; and

ACCESS SERVICE

2. General Regulations (Cont'd)

2.8 Sale or Transfer of an Operating Telephone Company's Assets and/or Stock to an Unaffiliated Third Party (Cont'd)

2.8.2 Undertaking of the Telephone Company Following a Transfer (Cont'd)

(B) (Cont'd)

- (2) use the reduced Commitment Level in all subsequent reviews/true-ups that measure the customer's compliance with established requirements for the service offering for the balance of the current term unless otherwise revised by: (i) the customer in accordance with the terms and conditions of the service offering; or (ii) the terms and conditions of such service offering. Upon renewal of the customer's term for such service offering, the terms and conditions set forth in the applicable section(s) of this Guide shall apply, including establishment of a new Commitment Level using only the quantity of services the customer purchases from the Telephone Company at the time of renewal.

For example, assume Frontier California Inc. transfers a portion of its assets to an unaffiliated third party. Further assume a customer with a DS1 Term Payment Plan and a Commitment Level of seventy-five (75) DS1 SALs is ten (10) DS1 SALs short of its Commitment Level at the next scheduled annual review (i.e., the customer has sixty-five (65) in-service DS1 SALs at the annual review). Also assume that ten (10) DS1 SALs were transferred to an unaffiliated third party as a result of the Transfer. In this case, the Telephone Company will reduce the customer's Commitment Level to sixty-five (65) DS1 SALs to reflect the Transfer. Since the customer has satisfied its reduced Commitment Level, no further action applies and the customer will not incur any penalty for such result during the annual review.

ACCESS SERVICE

2. General Regulations (Cont'd)

2.9 Technology Migration

(A) General

When a customer (for purposes of this Section 2.9, the term customer includes an Interexchange Carrier or Interexchange Common Carrier as defined in Section 2.6 preceding, an End User as defined in Section 2.6 preceding, or a customer who purchases Expanded Interconnection Service pursuant to Section 17 following) who subscribes to a DS1 Term Payment Plan (DS1 TPP) under Section 7.2.1(G) following, a DS3 Minimum Service Period under Section 7.2.6(B) following, or National Discount Plan (NDP) under Section 22.1 following wishes to disconnect certain High Capacity Services (each a Hi-Cap Disconnect) in order to replace them with a Telephone Company provided Ethernet private line service or a Telephone Company provided switched Ethernet service (each such service hereinafter referred to individually or collectively as a Replacing Service and each such replacement hereinafter referred to as a Technology Migration), the terms and conditions that apply to such Technology Migration are as follows:

- (1) For customers who subscribed to a DS1 TPP or NDP prior to December 2, 2010, the customer may choose to apply either the upgrade terms and conditions set forth in Section 7.2.1(G)(13) following for the DS1 TPP, or Section 22.1.7 following for NDP to a Technology Migration or the terms and conditions for a Technology Migration set forth in this Section 2.9. The terms and conditions that the customer chooses for its first such order placed on or after December 2, 2010 shall be the same terms and conditions that will apply to all of the customer's subsequent Technology Migration orders during the remainder of the current term commitment.
- (2) For customers who subscribe to or renew their subscription to a DS1 TPP or NDP on or after December 2, 2010, this Section 2.9 applies to Technology Migrations ordered on or after December 2, 2010.
- (3) For customers who subscribe to a DS3 Minimum Service Period, this Section 2.9 applies to Technology Migrations ordered on or after December 2, 2010.

- (B) In the event a customer fails to specify the provision to be applied under (A)(1) preceding, the Telephone Company will apply the regulations in this Section 2.9 for the initial Technology Migration order submitted and for all future Technology Migration orders the customer submits to migrate service to a different technology during the remainder of the current term commitment.

ACCESS SERVICE

2. General Regulations (Cont'd)

2.9 Technology Migration (Cont'd)

2.9.1 Service Under a DS1 Term Payment Plan

(A) Effect on DS1 TPP Circuit Termination Count

In the first annual true-up following a Technology Migration and in all subsequent annual true-ups until the expiration of the current term commitment, the Telephone Company will include, for each Hi-Cap Disconnect that was replaced by a Replacing Service on or after December 2, 2010, the number of DS1 circuit terminations for the Hi-Cap Disconnect in the calculation that measures compliance with the customer's commitment of TPP DS1 circuit terminations (as determined in the annual true-up) as if such Hi-Cap Disconnect had never occurred. Only those services that satisfy all of the requirements set forth in Section 2.9.4 following will be included in this calculation. The annual true-up process for the DS1 TPP is described in Section 7.2.1(G)(6) following.

Upon renewal of the customer's DS1 TPP, the DS1 circuit terminations of each Technology Migration that occurred during the expiring term commitment will not be included in the annual true-up calculations of the renewal term. However, for each Hi-Cap Disconnect that is replaced by a Replacing Service during the renewal term, the Telephone Company will include the number of DS1 circuit terminations for such Technology Migration in the annual true-up calculations in the same manner that such DS1 circuit terminations were included in the expiring term commitment.

(B) The customer remains responsible for satisfying any Minimum Period obligations on the service(s) being disconnected.

2.9.2 Service Under a DS3 Minimum Service Period

Liability under Section 7.2.6(E) following will not apply to the service(s) being disconnected if all of the requirements in Section 2.9.4 following are satisfied.

ACCESS SERVICE

2. General Regulations (Cont'd)

2.9 Technology Migration (Cont'd)

2.9.3 Service Under a National Discount Plan

(A) Effect on NDP at Annual True-Up

In the first Annual True-Up following a Technology Migration and in all subsequent Annual True-Ups until the expiration of the current term commitment, the Telephone Company will include, for each service that was replaced by a Replacing Service on or after December 2, 2010, the number of equivalent DS1 CTs and the number of equivalent DS1 CMs for each Hi-Cap Disconnect in the calculation of the average number of equivalent DS1 CTs and equivalent DS1 CMs which were actually in service over the preceding twelve (12) months as if such Hi-Cap Disconnect had never occurred.

Upon renewal of the customer's NDP, the number of equivalent DS1 CTs and the number of equivalent DS1 CMs of each Technology Migration that occurred during the expiring term commitment will not be included in the Annual True-Up calculations of the renewal term. However, for each Hi-Cap Disconnect that is replaced by a Replacing Service during the renewal term, the Telephone Company will include the number of equivalent DS1 CTs and the number of equivalent DS1 CMs for such Technology Migration in the Annual True-Up calculations in the same manner that such equivalent DS1 CTs and equivalent DS1 CMs were included in the expiring term commitment.

Only those services that satisfy all of the requirements set forth in Section 2.9.4 following will be included in this calculation. The Annual True-Up process for an NDP is described in Section 22.1.7 following.

(B) The customer remains responsible for satisfying any Minimum Period obligations on the service(s) being disconnected.

ACCESS SERVICE

2. General Regulations (Cont'd)

2.9 Technology Migration (Cont'd)

2.9.4 Requirements For a Technology Migration

In order to qualify for a waiver of liability under Section 2.9.2 preceding, or to qualify for the annual true up calculations under Section 2.9.1 preceding for the DS1 TPP or Section 2.9.3 preceding for NDP, all of the following requirements must be satisfied.

(A) Length of Commitment Requirements

If one (1) Hi-Cap Disconnect is replaced with one (1) Replacing Service, the Replacing Service must be purchased with a term commitment equal to or longer than the number of months remaining in the term commitment of the Hi-Cap Disconnect. If the Replacing Service does not offer a term commitment that is equal to or longer than the number of months remaining in the term commitment for the Hi-Cap Disconnect, then the customer must elect the longest term offered for the Replacing Service in order to satisfy this requirement.

Example: The customer disconnects one (1) DS1 High Capacity Service in order to replace it with one (1) Replacing Service. Assume that the customer has 24 months remaining on a DS1 TPP of 5 years. If the Replacing Service has a term period of at least 24 months, then the customer shall have satisfied this requirement.

If multiple Hi-Cap Disconnects are replaced with one (1) or more Replacing Services, each of the Replacing Services must be purchased with a term commitment equal to or longer than the most number of months remaining on the commitments of any of the Hi-Cap Disconnects. If the Replacing Service(s) does not offer a term commitment that is equal or longer than the most number of months remaining on the commitments of any of the Hi-Cap Disconnects, then the customer must elect the longest term offered for the Replacing Service(s) in order to satisfy this requirement.

ACCESS SERVICE

2. General Regulations (Cont'd)

2.9 Technology Migration (Cont'd)

2.9.4 Requirements For a Technology Migration (Cont'd)

(A) Length of Commitment Requirements (Cont'd)

Example 1: The customer disconnects two (2) DS1s in order to replace them with one (1) Replacing Service. Assume that the customer has 24 months remaining on a DS1 TPP of 3 years and 18 months remaining on a DS1 TPP of 2 years. If the Replacing Service has a term period of at least 24 months, then the customer shall have satisfied this requirement.

Example 2: Assume that in Example 1 above, one of the DS1 High Capacity Service has forty-eight (48) months remaining on a DS1 TPP of 5 years and that the longest term commitment offered on the Replacing Service is 3 years. The customer would have to elect the 3 year term commitment for its Replacing Service in order to satisfy this requirement.

(B) Bandwidth Requirements

The sum of the bandwidth of the Replacing Service(s) is equal to or greater than the sum of the bandwidth of the Hi-Cap Disconnects.

Example: If a customer disconnects two (2) DS1 High Capacity Services in order to replace them with one (1) 10 Mbps Replacing Service, then the customer shall have satisfied this requirement.

ACCESS SERVICE

2. General Regulations (Cont'd)

2.9 Technology Migration (Cont'd)

2.9.4 Requirements For a Technology Migration (Cont'd)

(C) Revenue Test Requirements

The Technology Migration must satisfy one of the following revenue tests:

(1) MRC Revenue Test

The MRC Revenue Test requires the total monthly recurring charges (MRCs) of the Replacing Service(s), counting only those discounted rate elements included in the term plan for the Replacing Service(s), be equal to or greater than the MRCs of the Hi-Cap Disconnect(s), counting only those discounted rate elements included in the term plan for the Hi-Cap Disconnect(s).

For example, assume a customer disconnects its DS1 High Capacity Service (Hi-Cap DS1 Disconnect) in order to replace it with a 100 Mbps Replacing Service. Further assume all of the following:

- the Hi-Cap DS1 Disconnect is provided under a DS1 TPP with a commitment period of 5 years at a rate of \$220.98 per month for the discounted rate elements; and
- the 100 Mbps Replacing Service is provided under a term plan with a 5 year commitment at a rate of \$900.00 per month for the discounted rate elements.

Since the MRC of \$900.00 for the 100 Mbps Replacing Service is greater than the MRC of \$220.98 for the Hi-Cap DS1 Disconnect, the customer shall have satisfied this requirement.

ACCESS SERVICE

2. General Regulations (Cont'd)

2.9 Technology Migration (Cont'd)

2.9.4 Requirements For a Technology Migration (Cont'd)

(C) Revenue Test Requirements (Cont'd)

(2) Overall Value/Revenue Test

The Overall Value/Revenue Test requires the overall value of the Replacing Service(s) be equal to or greater than the overall value of the remaining months of the current term commitment of the Hi-Cap Disconnect(s). The overall value of the Replacing Service(s) is calculated by multiplying the MRCs for the Replacing Service(s), counting only those discounted rate elements included in the term plan for the Replacing Service(s), by the number of months in the term commitment. The overall value of the Hi-Cap Disconnect(s) is calculated by multiplying the MRCs currently in effect for the Hi-Cap Disconnect(s), counting only those discounted rate elements included in the term plan for the service(s) being disconnected, by the total remaining months in the current term commitment.

For example, using the same assumptions in the example for the MRC revenue test in (1) preceding, further assume the customer disconnects the DS1 High Capacity Service in month thirty-six (36) of the 5 year commitment period (twenty-four (24) months remaining in the commitment period of the DS1 TPP for the Hi-Cap DS1 Disconnect).

Based on the above, the overall value of the Hi-Cap DS1 Disconnect is \$5,303.52 (\$220.98 x 24 months remaining) and the overall value of the 100 Mbps Replacing Service is \$54,000 (\$900.00 x 60 months). Since the overall value of the 100 Mbps Replacing Service is greater than the overall value of the Hi-Cap DS1 Disconnect, the customer shall have satisfied this requirement.

ACCESS SERVICE

2. General Regulations (Cont'd)

2.9 Technology Migration (Cont'd)

2.9.4 Requirements For a Technology Migration (Cont'd)

(D) Terminating Location Requirements

Terminating locations include End User locations, Interexchange Carrier locations, and physical or virtual EIS locations pursuant to Section 17 following.

(1) One Hi-Cap Disconnect Replaced by One Replacing Service

The terminating location(s) of the Replacing Service must satisfy one of the following requirements:

- (a) For service provided between two End User locations or two Interexchange Carrier locations, at least one of the locations of the Replacing Service must be the same as one of the locations of the Hi-Cap Disconnect; or
- (b) For service provided between an Interexchange Carrier location or a physical or virtual EIS location and an End User location, one of the locations of the Replacing Service must be the same as the End User location of the Hi-Cap Disconnect; or
- (c) For a multiplexed facility provided between an Interexchange Carrier location, a physical or virtual EIS location, or an End User location and a Telephone Company Hub where multiplexing functions are performed, one of the locations of the Replacing Service must be the same as the Interexchange Carrier location, physical or virtual EIS location, or End User location, respectively, of the Hi-Cap Disconnect.

ACCESS SERVICE

2. General Regulations (Cont'd)

2.9 Technology Migration (Cont'd)

2.9.4 Requirements For a Technology Migration (Cont'd)

(D) Terminating Location Requirements (Cont'd)

(2) Multiple Hi-Cap Disconnects Replaced by One or More Replacing Services

When multiple Hi-Cap Disconnects are replaced by one or more Replacing Service(s), at least one of the locations for each of the Replacing Service(s) must be the same location as each of the End User locations of each of the Hi-Cap Disconnects, except where the locations involved are two (2) Interexchange Carrier locations or two (2) End User locations in which case at least one of the locations for each of the Replacing Service must be the same as one of the Interexchange Carrier locations or End User locations, respectively, of each of the Hi-Cap Disconnects.

Example where both locations are End User locations: The customer has a DS1 High Capacity Service between locations A and B and a DS1 High Capacity Service between locations C and D. The two Replacing Services are between locations B and E and between locations D and F. Since each DS1 High Capacity Service has one location in common with its Replacing Service, this requirement is satisfied.

Example where all locations are End User locations: The customer has three (3) DS1 High Capacity Services between locations A and B, C and D, and E and F. The two Replacing Services are between locations B and X and between locations D and Y. Since the Replacing Services do not have a common location with the DS1 High Capacity Service between locations E and F, this requirement is not satisfied. However, if the customer qualifies for a one-for-one replacement under (D)(1) preceding, this requirement would be satisfied for two of the DS1 High Capacity Services. The DS1 High Capacity Service between locations E and F, for which no common location exists, would not meet the requirements for a Technology Migration.

ACCESS SERVICE

2. General Regulations (Cont'd)

2.9 Technology Migration (Cont'd)

2.9.4 Requirements For a Technology Migration (Cont'd)

(E) Timing Requirements

The order for each Hi-Cap Disconnect must be completed within three (3) months of the date that the Replacing Service(s) is installed. Failure to disconnect each Hi-Cap Disconnect within three (3) months will result in the customer not satisfying this requirement.

(F) Notification Requirements

Within ten (10) business days of the date the Replacing Service(s) is ordered, the customer must provide the Telephone Company with the all of following:

- (1) the circuit identification number(s) of the each Hi-Cap Disconnect;
and
- (2) the circuit identification number(s) of the Replacing Service(s); and
- (3) the terminating locations of the services involved (including both the Replacing Service(s) and the Hi-Cap Disconnect(s)).

Failure to provide such information within the stated timeframe will result in the customer not satisfying this requirement.

ACCESS SERVICE

2. General Regulations (Cont'd)

2.10 Initial Transfer of Assets from Predecessor Company

The original issuing carriers of this Guide were created by a transfer of assets from an unaffiliated third party. This Section 2.10 governs treatment of customers who, at the time of the transfer of assets from the predecessor company, subscribed to a service offering under this Guide that aggregates the customer's purchases from the Telephone Company to measure compliance with such service offering or participated in an SLA that aggregates the customer's measured transactions.

- (A) When a customer subscribes to a service offering under this Guide that aggregates the customer's purchases from the Telephone Company to measure compliance with such service offering or the customer participates in a SLA that aggregates the customer's measured transactions, and the service offering or SLA includes terms and conditions pertaining to a transfer, the terms and conditions pertaining to a transfer will apply to that service offering or SLA as if the Telephone Company were the predecessor company.
- (B) When customer subscribes to a service offering under this Guide that aggregates the customer's purchases from the Telephone Company to measure compliance with such service offering or the customer participates in a SLA that aggregates the customer's measured transactions, and the service offering or SLA does not include terms and conditions pertaining to a Transfer, Sections 2.8 preceding will apply as if the Telephone Company were the predecessor company.

For example, if a customer subscribed to a service offering with the predecessor company that aggregates the customer's measured transactions, and the transfer of assets resulted in the customer meeting the conditions described in 2.8.1(B) and (C) preceding with respect to the assets transferred to the Telephone Company, the provisions of 2.8.2 preceding will apply with respect to prorating any Minimum Requirements.

ACCESS SERVICE

3. RESERVED FOR FUTURE USE

ACCESS SERVICE

4. RESERVED FOR FUTURE USE

ACCESS SERVICE

5. Ordering Special Access Service

This section sets forth the regulations and order related charges for Access Orders for Special Access Services. These charges are in addition to other applicable charges as set forth in other sections of this Guide.

5.1 Access Service Request Requirements

An ASR is used by the Telephone Company to receive orders for the following types of services requested by the customer:

- Special Access as in Section 7, and
- Other Services as in other sections of the tariff.

When placing an order for Access Services, the customer must complete a Telephone Company Access Service Request and shall provide the information as required in 5.1.1, 5.1.2, and 5.1.3 following.

5.1.1 General

A customer may order any number of services of the same type and between the same premises on a single Access Service Request. All details for services for a particular order must be identical except for those for multipoint service.

A customer may order access service on behalf of the customer's end user. The customer must provide the Telephone Company all the necessary information as set forth in this section.

The customer shall provide all information necessary for the Telephone Company to provide and bill for the requested service. In addition to the order information required in 5.1.2 and 5.1.3 following, the customer must also provide:

- Customer name and premises address(es)
- Billing name and address (when different from customer name and address).
- Customer contact name(s) and telephone number(s) for the following provisioning activities: order negotiation, order confirmation, interactive design, installation and billing.

ACCESS SERVICE

5. Ordering Special Access Service (Cont'd)

5.1 Access Service Request Requirements (Cont'd)

5.1.2 Reserved

ACCESS SERVICE

- 5. Ordering Special Access Service (Cont'd)
 - 5.1 Access Service Request Requirements (Cont'd)
 - 5.1.2 Reserved

ACCESS SERVICE

- 5. Ordering Special Access Service (Cont'd)
 - 5.1 Access Service Request Requirements (Cont'd)
 - 5.1.2 Reserved (Cont'd)

ACCESS SERVICE

- 5. Ordering Special Access Service (Cont'd)
 - 5.1 Access Service Request Requirements (Cont'd)
 - 5.1.2 Reserved

ACCESS SERVICE

5. Ordering Special Access Service (Cont'd)

5.1 Access Service Request Requirements (Cont'd)

5.1.2 Reserved

ACCESS SERVICE

5. Ordering Special Access Service (Cont'd)

5.1 Access Service Request Requirements (Cont'd)

5.1.2 Reserved

ACCESS SERVICE

- 5. Ordering Special Access Service (Cont'd)
 - 5.1 Access Service Request Requirements (Cont'd)
 - 5.1.2 Reserved (Cont'd)

ACCESS SERVICE

- 5. Ordering Special Access Service (Cont'd)
 - 5.1 Access Service Request Requirements (Cont'd)
 - 5.1.2 Reserved (Cont'd)

ACCESS SERVICE

5. Ordering Special Access Service (Cont'd)

5.1 Access Service Request Requirements (Cont'd)

5.1.2 Reserved

ACCESS SERVICE

5. Ordering Special Access Service (Cont'd)

5.1 Access Service Request Requirements (Cont'd)

5.1.3 Special Access Services

(A) General

When placing an order for Special Access Services, the customer must provide the requirements as follows:

For all Special Access Services, the customer must specify the customer designated premises or Hubs involved, the type of service, (e.g., Voice Grade, High Capacity, etc.) the channel interface, technical specification package and options desired. The customer must also indicate the jurisdiction of the circuit as set forth in 7.1.9 following. For DS3 High Capacity Services, the customer must indicate the level of capacity. For multipoint services, the channel interface at each premises may, at the request of the customer, be different but all such interfaces shall be compatible. (C)
(C)

Where the Special Access Service is exempt from the Special Access Surcharge, the customer shall furnish with the Access Service Request the certification as set forth in 7.2.1(E) following. Exemption certifications may be provided in writing or by use of an Access Service Request.

5.1.4 Reserved

ACCESS SERVICE

5. Ordering Special Access Service (Cont'd)

5.1 Access Service Request Requirements (Cont'd)

5.1.5 Reserved for Future Use

5.1.6 Provision of Other Services

(A) Testing Service, Additional Labor, Restoration Priority and Special Facilities Routing shall be ordered with an Access Service Request or as set forth in (B) following. The rates and charges for these services, as set forth in other sections of this Guide, will apply in addition to the ordering charges set forth in this section and the rates and charges for the Access Service with which they are associated.

(B) Where possible, the Telephone Company will allow the services listed preceding to be subsequently added to an Access Service Request at any time, up to and including the service date for the Access Service. When added subsequently, charges for a design change as set forth in 5.3.1(C) following will apply when an engineering review is required.

(C) Additional Engineering is not an ordering option, but will be applied to an Access Service Request when the Telephone Company determines that Additional Engineering is necessary to accommodate a customer request. Additional Engineering conditions and charges are as set forth in 8.1 following and are in addition to the regulations, rates and charges specified in this section.

ACCESS SERVICE

5. Ordering Special Access Service (Cont'd)

5.1 Access Service Request Requirements (Cont'd)

5.1.7 Access Order Service Date Intervals

Access Service is provided with Service Date Intervals. The Service Date Interval is that period of time which the Telephone Company requires to properly provision the service and begins when the customer submits a completed Access Service Request for service, as set forth in 5.1 preceding.

The Telephone Company shall publish and make available to all customers, upon reasonable request, a schedule of Service Date Intervals applicable for Special Access Services. The schedule shall specify the services and the quantities of services that can be provided in the Service Date Intervals. Service Date Interval schedules are provided during regular business days at Telephone Company offices at which the customer places an order for Access Service.

Access Services provided in a Service Date Interval will be installed during Telephone Company business days. If a customer requests that installation be done outside of scheduled work hours, and the Telephone Company agrees to this request, the customer will be subject to applicable Additional Labor Charges as set forth in 8.2. following.

5.1.8 Selection of Facilities For Access Order

When there are analog or digital high capacity facilities to a Hub on order or in service for the customer's use, or a Switched Access Service that is part of a Shared Use Special Access facility including a DS3 Premises Multiplexer as described in Sections 5.1.9 and 7.11.4(5) following, the customer may request a specific channel or transmission path be used to provide the Switched or Special Access Service requested in an Access Service Request. The Telephone Company will make a reasonable effort to accommodate the customer request.

For all other Access Service Requests, the option to request a specific transmission path or channel is not provided except as provided for under Special Facilities Routing as set forth in 11. following.

ACCESS SERVICE

5. Ordering Special Access Service (Cont'd)

5.1 Access Service Request Requirements (Cont'd)

5.1.9 Shared Use Facilities

Shared Use (i.e., Switched and Special Access Services provided over the same analog or digital high capacity facilities) is allowed. Shared use facilities to a Hub will be ordered and provided as either Switched or Special Access Service. While shared use is allowed, individual services utilizing these facilities must be ordered either as Switched Access Service or Special Access Service. When placing the order for the individual service(s), the customer must specify a channel assignment for each service ordered.

When the shared use facility is associated with a DS3 Premises Multiplexer as set forth in Section 7.11.4(5) following, the shared use facility must be ordered as Special Access.

5.1.10 Expanded Interconnection Services (EIS)

When ordering Expanded Interconnection Services (EIS) as described in 17.5, the customer shall place an ASR for the Switched Access or Special Access Cross Connect, as described in 6.5.13 and 7.2.1(F) to interconnect the facilities of the Telephone Company to the facilities of the customer. Each service application used in conjunction with EIS will require a separate ASR. When ordering additions or changes to the existing EIS facilities, the customer must refer to the specific EIS facilities affected by the addition or change.

5.1.11 Reserved for Future Use

5.1.12 Special Construction

(A) When the Telephone Company determines that the installation of service meets the guidelines of the Special Construction tariffs as set forth in Section 1.3 preceding, the customer is notified and conditions are negotiated as prescribed by the Special Construction tariffs.

(B) The regulations, rates and charges for Special Construction (as set forth in the tariffs referenced in Section 1.3 preceding) are in addition to the regulations, rates and charges specified in this section.

ACCESS SERVICE

5. Ordering Special Access Service (Cont'd)

5.2 Access Services Provided by More than One Telephone Company

The Telephone Company will provide Access Services under this Guide where more than one Telephone Company is involved in the provision of Access Service as set forth in (A), (B) or (C). The Multiple Company Billing arrangement, as set forth in (B) will be used for all Special Access Services.

(A) Reserved

ACCESS SERVICE

5. Ordering Special Access Service (Cont'd)

5.2 Access Services Provided by More than One Telephone Company (Cont'd)

(B) Multiple Company Billing

Access services subject to Multiple Company Billing will be provided by the Telephone Companies involved in accordance with the Exchange Carrier Standards Association's Multiple Exchange Carrier Access Billing Guidelines (MECAB) and Multiple Exchange Carrier Ordering and Design Guidelines (MECOD).

For all Special Access Services, the customer shall submit an ASR to each Telephone Company involved in providing the service.

Each Telephone Company will provide the appropriate access service elements within its operating territory to a physical point of interconnection with the other involved Telephone Company(ies). The physical point of interconnection is the location where one Telephone Company's facilities connect with another Telephone Company's facilities.

Each Telephone Company that receives an order will bill the customer for the appropriate access service elements provided by each respective Telephone Company as set forth in 2.4.7 (B) preceding.

(C) EAS Arrangements

Where a customer utilizes FGA or BSA-A to originate and/or terminate calls within an Extended Area Service (EAS) calling area provided by more than one telephone company, as set forth in 2.4.7(C) preceding, the customer shall submit an ASR for FGA or BSA-A service in the manner set forth in (A) preceding. The customer shall also provide a copy of the ASR to any other Telephone Company involved in providing the service within the EAS calling area.

ACCESS SERVICE

5. Ordering Special Access Service (Cont'd)

5.3 Access Order Charges

5.3.1 Access Service Request Modifications

The customer may request a modification of its Access Service Request prior to the service date. The Telephone Company will make every effort to accommodate a requested modification when it is able to do so with the normal work force assigned to complete such an order within normal business hours. If the modification cannot be made with the normal work force during normal business hours, the Telephone Company will notify the customer. If the customer still desires the Access Service Request modification, the Telephone Company will schedule a new service date. All charges for Access Service Request modifications will apply on a per occurrence basis.

Any increase in the number of Special Access Service circuits will be treated as a new Access Service Request (for the increased amount only).

If order modifications are necessary to satisfy the transmission performance for a Special Access Service ordered by a customer, these changes will be made without order modification charges being incurred by the customer.

(A) Service Date Change Charge

- (1) Access Order service dates for the installation of new services or rearrangements of existing services may be changed, but the new service date may not exceed the original service date by more than 30 calendar days except as specified following. When, for any reason, the customer indicates that service cannot be accepted for a period not to exceed 30 calendar days, and the Telephone Company accordingly delays the start of service, a Service Date Change Charge will apply.

If a customer or customer's end user is unable to accept service within 30 calendar days, of the original service date, the customer may elect one of the following:

- (a) the customer may take no action, and the original order will be canceled by the Telephone Company on the 31st day with the appropriate Cancellation Charge as set forth in 5.3.2(C) following applied; or
- (b) the customer may choose to commence billing for the service on the 31st day.

ACCESS SERVICE

5. Ordering Special Access Service (Cont'd)

5.3 Access Order Charges (Cont'd)

5.3.1 Access Service Request Modifications (Cont'd)

(A) Service Date Change Charge (Cont'd)

(1) (Cont'd)

When a customer chooses the option to commence billing for the service on the 31st day, the customer must place an Access Order Modification to the existing Access Order prior to the 31st calendar day after the original service date to request a new service date. The new service date may not exceed the original service date by more than 120 calendar days. A Service Date Change Charge will not apply for such service date change; however, if subsequent additional service date changes are requested after calendar day 31, the Service Date Change Charge will apply, per request.

When a customer chooses the option to commence billing for the service on the 31st day, monthly recurring charges for the service will begin accruing at calendar day 31 after the original service date. The initial or subsequent bill for the service will include these accrued charges and any applicable nonrecurring charges in addition to billable charges specified in Section 2.4.1(B) preceding.

If the customer requested service date is more than 120 calendar days after the original service date, or if the customer or the customer's end user is unable to accept the service within 120 calendar days of the original service date, the order will be cancelled by the Telephone Company on the 121st day. In the event of any such cancellation, or if the customer cancels the order after the 30th day, the customer will be billed the accrued monthly recurring charges specified preceding plus any applicable nonrecurring charges. These charges will be computed commencing at day 31 after the original service date up to and including the cancellation date. The customer will be responsible for applicable minimum period and termination liability charges.

ACCESS SERVICE

5. Ordering Special Access Service (Cont'd)

5.3 Access Order Charges (Cont'd)

5.3.1 Access Service Request Modifications (Cont'd)

(A) Service Date Change Charge (Cont'd)

- (2) If the Telephone company determines it can accommodate the customer's request without delaying service dates for orders of other customers, a new service date may be established that is prior to the original standard or negotiated interval service date.

If the service date is changed to an earlier date, the customer will be notified by the Telephone Company that Expedited Order Charges as set forth in (D) following apply. Such charges will apply in addition to the Service Date Change Charge.

- (3) Except as otherwise specified in (A)(1) preceding, a Service Date Change Charge will apply, on a per order per occurrence basis, for each service date changed after the Plant Test Date of the ASR. The applicable charge is:

	<u>CHARGE</u>
Service Date Change Charge, per order	\$28.00

(B) Reserved for Future Use

ACCESS SERVICE

5. Ordering Special Access Service (Cont'd)

5.3 Access Order Charges (Cont'd)

5.3.1 Access Service Request Modifications (Cont'd)

(C) Design Change Charge

The customer may request a design change to the service ordered. A design change is any change to an Access Service Request which requires engineering review. An engineering review is a review by Telephone Company personnel, of the service ordered and the requested changes to determine what changes in the design, if any, are necessary to meet the changes requested by the customer. Design changes include such things as the addition or deletion of optional features or functions. Design changes do not include a change of end user premises or Special Access Service circuit type. Changes of this nature will require the issuance of a new order and the cancellation of the original order with appropriate cancellation charges applied.

The Telephone Company will review the requested change, notify the customer whether the change is a design change, if it can be accommodated and if a new service date is required. If the customer authorizes the Telephone Company to proceed with the design change, a Design Change Charge will apply. The Design Change Charge will apply on a per order per occurrence basis, for each order requiring a design change. The applicable charge is:

	<u>Rate</u>	
Design Change Charge, per order		
California	\$7,948.02	(C)
Texas	\$7,948.02	(C)

If a change of service date is required, the Service Date Change Charge as set forth in (A) preceding will also apply.

ACCESS SERVICE

5. Ordering Special Access Service (Cont'd)

5.3 Access Order Charges (Cont'd)

5.3.1 Access Service Request Modifications (Cont'd)

(D) Expedited Order Charge

A customer may request an expedited service date. When this situation occurs, charges will be applicable as in 8.2. The Telephone Company will provide an estimate of the charges to the customer. The customer must accept the price estimate prior to the Telephone Company's performing the expedite. The actual charges billed to the customer will be no more than 10 percent over the estimate.

Access Ordering Guidelines prohibit expedite orders when disconnecting services (N)
(N)

ACCESS SERVICE

5. Ordering Special Access Service (Cont'd)

5.3 Access Order Charges (Cont'd)

5.3.2 Cancellation of an Access Service Request

A customer may cancel an Access Service Request on any date after receipt of the Access Service Request by the Telephone Company and prior to the installation of service. The cancellation date is the date the Telephone Company receives written or verbal notice from the customer that the Access Service Request order is to be canceled. The verbal notice must be followed by written confirmation within 10 days. If written confirmation of the cancellation is not received by the Telephone Company, the verbal notice will not be considered a valid cancellation notice. When a customer cancels an Access Service Request for the discontinuance of service, no charges apply for the cancellation.

(A) Delay of Service Date by Customer

Subject to Section 5.3.1 preceding, a customer may negotiate an extension of a service date of an Access Order for installation of new services or rearrangements of existing services.

(B) Delay of Service Date by Telephone Company

If the Telephone Company misses a service date by more than 30 days due to circumstances over which it has direct control (excluding, e.g., Acts of God, governmental requirements, work stoppages and civil commotions), the customer may cancel the Access Service Request without incurring cancellation charges.

ACCESS SERVICE

5. Ordering Special Access Service (Cont'd)

5.3 Access Order Charges (Cont'd)

5.3.2 Cancellation of an Access Service Request (Cont'd)

(C) When a customer cancels an Access Service Request prior to the service date, the Cancellation Charge specified in (1) through (7) following, shall apply.

(1) When an ASR for Special Access Service is canceled on or after the Application Date, except where there is a specific cancellation charge set forth such as after the 30th day, the Cancellation Charge is the Nonrecurring Charge for the service(s) multiplied by the quantity ordered on a per ASR basis. (C)

(C)

(2) Reserved

For services specified in 3 through 5 following: the cancellation charge is the charge shown for the last date passed on the order and will apply when a customer cancels an order or part of an order prior to accepting service.

(3) Reserved for Future Use

(4) Reserved for Future Use

(5) Reserved for Future Use

(6) Reserved for Future Use

(7) Dedicated SONET Entrance Facilities
Cancellation Charges Which Apply After the Order Date

-	per STS1 DSEF Termination	\$1,000.00
---	---------------------------	------------

ACCESS SERVICE

5. Ordering Special Access Service (Cont'd)

5.3 Access Order Charges (Cont'd)

5.3.2 Cancellation of an Access Service Request (Cont'd)

(D) Partial Cancellation Charge

Any decrease in the number of ordered Special Access Service circuits, on a pending ASR will be treated as a partial cancellation. The charge will be determined by multiplying the total special access nonrecurring charge for the canceled portion of the order by the number of business days elapsed since the order date and dividing that figure by the number of days in the service interval.

ACCESS SERVICE

5. Ordering Special Access Service (Cont'd)

5.3 Access Order Charges (Cont'd)

5.3.3 Minimum Period Charges (Cont'd)

When Access Service is disconnected prior to the expiration of the minimum period, charges are applicable for the balance of the minimum period. A disconnect constitutes facilities being returned to available inventory.

For purposes of applying minimum period charges, the disconnect date shall be thirty (30) business days after the date the Telephone Company receives written notification from the customer or the date the customer requests service be disconnected, if longer than thirty (30) business days. (C)

Except as specifically stated in other sections of this Guide, the Minimum Period Charge for monthly billed services will be determined as follows: (C)

For Special Access Service, and Direct-Trunked Transport services the charge for a month or fraction thereof is the applicable monthly rates for the service as set forth in 7.2.2 following.

The Minimum Period Charge for part-time Television and Program Audio Services is the applicable daily rate for the service as set forth in 7.2.2 following.

For Optical Networking services, the charge is the applicable monthly rate as set forth in Section 20 following.

For services provided under a National Discount Plan (NDP), the discount percentage specified in Section 22.1 following shall be applied to the applicable monthly rates.

ACCESS SERVICE

6. RESERVED FOR FUTURE USE

ACCESS SERVICE

7. Special Access Service

7.1 Provision of Special Access Service

Special Access Service provides a dedicated transmission path to connect customer designated premises*, either directly or through a Telephone Company hub where bridging or multiplexing functions are performed, or through a DS3 Premises Multiplexer at a customer designated premises where multiplexing functions are performed, or to connect a customer's transmission equipment and facilities using a DS1 or DS3 Cross Connect arrangement where the customer is provided Expanded Interconnection Service (EIS) as defined in Section 17. Special Access Service may also be combined with Switched Access Services in the provision of a customer's interstate communications service (e.g., WATS, 800, 888 or WATS-type Services). Special Access Service includes all exchange access not utilizing Telephone Company central office switches.

Certain Special Access Services listed in this section of the tariff may not be currently offered in all Telephone Company locations but may be provided upon customer request, on an individual case basis, if facilities can be made available with reasonable effort. The Telephone Company will work cooperatively with the Customer to provide the service on a timely basis.

7.1.1 Circuit Types

There are five types of circuits used to provide Special Access Services:

- Voice Grade (VG)
- Program Audio (AP)
- Video Digital Transport TV-1 Analog (TV)
- Digital Data (DA)
- High Capacity (HC)

These circuits can be either analog or digital. Analog circuits are differentiated by frequency spectrum and bandwidth. Digital connections are differentiated by bit rate.

Each of the five circuits has its own characteristics. All of the circuit types are subdivided by one or more of the following:

- Transmission specifications,
- Bandwidth,
- Speed (i.e., bit rate),
- Spectrum

* Telephone Company Centrex CO-like switches are considered to be customer premises for purposes of this Guide.

ACCESS SERVICE

7. Special Access Service (Cont'd)

7.1 Provision of Special Access Service (Cont'd)

7.1.1 Circuit Types (Cont'd)

The circuit descriptions set forth in this section specify the characteristics of the basic circuit and indicates whether the circuit is provided between customer designated premises, or between a customer designated premises and a Telephone Company hub where bridging or multiplexing functions are performed, or through a DS3 Premises Multiplexer where multiplexing functions are performed at a customer designated premises, or between a customer designated premises and a Telephone Company WATS Serving Office.

Customers can order a basic circuit and select from a list of available technical specifications packages (customized or predefined), channel interfaces, and optional features to design a circuit which meets the Customer's specific communications needs. For purposes of ordering circuits, each has been identified as a type of Special Access circuit. However, such identification is not intended to limit a customer's use of the circuit, nor to imply that a circuit is limited to a particular use.

The optional features and functions available with each type of basic circuit are included in the individual service description sections following. The optional features and functions information also indicates with which technical specifications packages they are available.

When a customized circuit is ordered, the Telephone Company may determine that Additional Engineering is required to meet the customer's request for service. The customer will be notified whether Additional Engineering charges apply and will be given an estimate of the hours to be billed before any further action is taken on the order. Additional engineering charges are determined as set forth in 8. 1 following.

ACCESS SERVICE

7. Special Access Service (Cont'd)

7.1 Provision of Special Access Service (Cont'd)

7.1.2 Service Configurations (Cont'd)

(A) Two-Point Service

A two-point service connects two customer designated premises, either on a directly connected basis or through a hub where multiplexing functions are performed, or through a DS3 Premises Multiplexer where multiplexing functions are performed at a customer designated premises. A Voice Grade Special Access Circuit may be provided as a two-point service connecting an end user premise and a Telephone Company switch when Special Access is used in conjunction with Switched Access as set forth in 6.3.2(T) for Switched Access Interface Arrangements.

All types of Special Access Service may be provided as two-point service.

The following diagram depicts an example of a two-point Voice Grade service connecting two customer designated premises located 15 miles apart. The service is provided with the optional feature of C-Type conditioning.

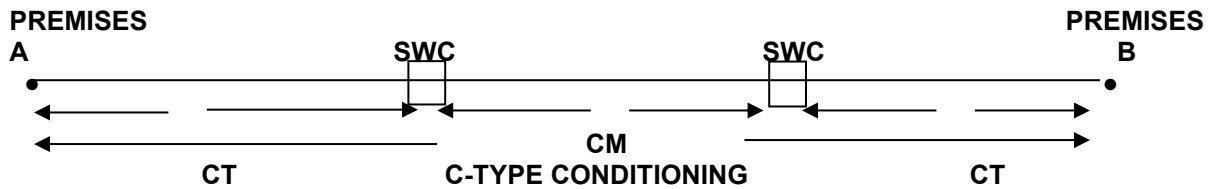

- CT - Circuit Termination
- CM - Circuit Mileage
- SWC - Serving Wire Center

Applicable rate elements are:

- Circuit Termination (2 applicable)
- Circuit Mileage (fixed rate plus rate per airline mile between SWC)
- C-Type Conditioning Optional Feature

In addition, a Special Access Surcharge and charges for additional Optional Features and Functions may apply.

ACCESS SERVICE

7. Special Access Service (Cont'd)

7.1 Provision of Special Access Service (Cont'd)

7.1.2 Service Configurations (Cont'd)

(B) Multipoint Service

Multipoint service connects three or more customer designated premises through a Telephone Company hub (i.e., bridging locations). Only certain types of Special Access Service are provided as multipoint service. These are so designated in the Service Descriptions for the appropriate circuit.

The circuit between hubs on a multipoint service is a mid-link. There is no limitation on the number of mid-links, but the use of more than three mid-links in tandem may degrade the quality of multi-point facilities.

Multipoint service utilizing a customized technical specifications package, as set forth in 7.1.3, will be provided when technically possible.

When ordering, the customer will specify the desired bridging hub(s). National Exchange Carrier Association Tariff FCC No. 4 identifies serving wire centers, hub locations and the type of bridging functions available.

ACCESS SERVICE

7. Special Access Service (Cont'd)

7.1 Provision of Special Access Service (Cont'd)

7.1.2 Service Configurations (Cont'd)

(B) Multipoint Service (Cont'd)

The following diagram depicts an example of a Voice Grade multipoint service connecting four customer premises via two customer specified bridging hubs.

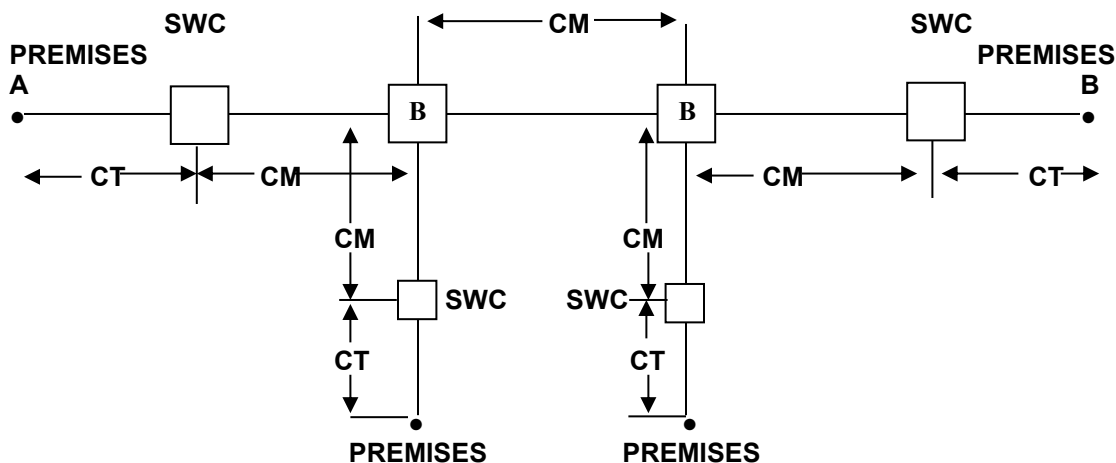

- CT - Circuit Termination
- CM - Circuit Mileage
- B - Bridging
- SWC - Serving Wire Center

Applicable rate elements are:

- Circuit Termination (4 applicable)
- Circuit Mileage (5 sections-fixed rate plus rate per mile between SWC)
- Bridging Optional Features (6 applicable, i.e., each bridge port)

In addition, the Special Access Surcharge, Message Station Equipment Recovery Charge, and charges for other Optional Features and Functions may be applicable.

ACCESS SERVICE

7. Special Access Service (Cont'd)

7.1 Provision of Special Access Service (Cont'd)

7.1.3 Technical Specifications Packages

Information pertaining to the technical specifications packages indicates the transmission parameters that are available with each package. This information is included in each individual service description section in 7.3 through 7.10 following, in a matrix format with the transmission parameters listed down the left side and the packages listed across the top. Each package is identified by a code, e.g., VGC. The first two letters of the code indicate the category of Special Access Service to which the parameters are applicable. These two letter codes are shown above in parentheses following the category of Special Access Service.

The letter "C" following the two letter code indicates the technical specifications package for a customized service. A numeric or alpha-numeric designation following the two letter code indicates the specific predefined package. For a customized service, the customer may select any parameters available with that category of service as long as the parameters are compatible. When appropriate, the Technical Reference which contains detailed specifications for the parameters is shown following the matrix.

All services installed after the effective date of this Guide will conform to the transmission specification standards contained in this Guide or in the following Technical References for each category of service:

Voice Grade	TR-NWT-000335, Issue 3 PUB 41004, Table 4
Program Audio	GR- 337-CORE, Issue 1
Video	GR- 338-CORE, Issue 1
Digital Data	TR-NWT-000341, Issue 2 PUB 62310
High Capacity	GR-342-CORE, Issue 1 GR-54-CORE, Issue 1

The Telephone Company will maintain existing transmission specifications on services installed prior to the effective date of this Guide, except that existing services with performance specifications exceeding the standards listed in this provision will be maintained at the performance levels specified in this Guide.

Customized technical specifications packages will be provided where technically feasible. If the Telephone Company determines that the requested parameter specifications are not compatible, the customer will be advised and given the opportunity to change the order.

ACCESS SERVICE

7. Special Access Service (Cont'd)

7.1 Provision of Special Access Service (Cont'd)

7.1.4 Channel Interfaces

Channel interfaces at each point of termination on a two-point service may be symmetrical or asymmetrical. On a multipoint service they may also be symmetrical or asymmetrical, but communications can only be provided between compatible channel interfaces. Only certain channel interfaces are compatible. These are set forth in 9. following, in a combination format.

Only certain channel interface combinations are available with the predefined technical specifications packages. These are delineated in the Technical References set forth in 7.1.3 preceding. When a customized circuit is requested, all channel interface combinations available with the specified type of service are available with the customized circuit.

7.1.5 Alternate Use

Alternate Use occurs when a service is arranged by the Telephone Company so that the customer can select different types of transmission at different times. A customer may use a service in any privately beneficial manner. However, where technical or engineering changes are required to effectuate an alternate use, the Telephone Company will make such special arrangements available on an individual case basis.

The arrangement required to transfer the service from one operation to the other (i.e., the transfer relay and control leads) will be rated and provided on an individual case basis and filed in Section 12., Specialized Service or Arrangements. The customer will pay the stated tariff rates for the Access Service rate elements for the service ordered (i.e., Circuit Terminations, Circuit Mileage [as applicable] and Optional Features and Functions [if any]).

7.1.6 Special Facilities Routing

A customer may request that the Special Access used be specially routed. The regulations, rates and charges for Special Facilities Routing are as set forth in Section 11. following.

ACCESS SERVICE

7. Special Access Service (Cont'd)

7.1 Provision of Special Access Service (Cont'd)

7.1.7 Design Layout Report

At the customer request, the Telephone Company will provide the make-up of the facilities and services provided under this Guide as Special Access Service to aid the customer in designing its overall service. The information will be provided to the customer at no charge in the form of a Design Layout Report and will be reissued or updated whenever the described facilities are materially changed.

7.1.8 Acceptance Testing

At the customer's request, the Telephone Company will cooperatively test, at the time of installation and at no additional charge, the following parameters:

- (A) For Voice Grade analog services, acceptance testing will include tests for loss, 3-tone slope, DC continuity, operational signaling, C-notched noise, and C-message noise as applicable according to the order for service. Voice Grade services acceptance testing will also include a balance (improved loss) test if the customer has ordered that optional feature.
- (B) For services other than Voice Grade, acceptance tests will include tests for the parameters applicable to the service as specified by the customer in the order for service.

In addition to the above tests, Additional Cooperative Acceptance Testing and Nonscheduled Testing, as described in 8.4 following, are available at the customer's request. All test results will be made available to the customer upon request.

ACCESS SERVICE

7. Special Access Service (Cont'd)

7.1 Provision of Special Access Service (Cont'd)

7.1.9 Jurisdictional Determination

- (A) Special Access circuits carrying exclusively interstate traffic will be provided in accordance with the applicable rules and regulations of this Guide.

When mixed interstate and intrastate Special Access Service is provided, the jurisdiction will be determined as follows:

- (1) If the customer's estimate of the interstate traffic on the circuit involved constitutes 10% or less of the total traffic on that circuit, the circuit will be provided in accordance with the applicable rules and regulations of the appropriate intrastate tariff.
 - (2) If the customer's estimate of the interstate traffic on the circuit involved constitutes more than 10% of the total traffic on that circuit, the circuit will be provided in accordance with the applicable rules and regulations of this Guide.
- (B) If a billing dispute arises or a regulatory commission questions the reported jurisdiction, the Telephone Company will ask the customer to provide the information the customer uses to determine the jurisdiction of the circuit. The customer shall supply the information within 30 days of the Telephone Company request. The customer shall keep records of system design and functions from which the jurisdiction of its special access circuits can be ascertained. Upon request of the Telephone Company the customer shall make the records available for inspection as reasonably necessary for purposes of verification of the reported jurisdiction.
- (C) Customer certification of the jurisdiction of special access circuits is accomplished by indicating the jurisdiction of the circuit (interstate or intrastate) on the Access Service Request. Customer certification of the jurisdiction of special access circuits in place as of the effective date of these revisions shall be provided to the Telephone Company in the form of written correspondence indicating the jurisdiction of each special access circuit.
- (D) Customers reporting a change in the jurisdiction of special access circuits subject to individual case basis (ICB) rates and charges set forth in this Guide will not be subject to termination liability charges unless the change results in the termination of the service.

ACCESS SERVICE

7. Special Access Service (Cont'd)

7.1 Provision of Special Access Service (Cont'd)

7.1.10 Interzone Service

Interzone Service provides the transmission facilities for DS1 and DS3 Special Access between two service areas within a state in association with two customer designated locations within different service areas. The Circuit Mileage will be applied as set forth under 7.2.1(B).

Interzone Service is available between the following service areas, where facilities and conditions permit.

<u>State</u>	<u>Location "A"</u>	<u>CLLI Code</u>	<u>Location "Z"</u>	<u>CLLI Code</u>
California*	Ontario #	ONTRCAXP	Palm Springs #	PLSPCAXG
	San Bernardino #	SNBRCAKX	Palm Springs	PLSPCAXG

Telephone Company's Office

ACCESS SERVICE

7. Special Access Service (Cont'd)

7.2 Rate Categories, Applications and Regulations

This section contains the specific regulations governing the rates and charges that apply for Special Access.

7.2.1 Rate Categories

The following rate categories apply to Special Access Service:

- Circuit Terminations
- Circuit Mileage
- Optional Features and Functions
- Non Recurring Charges
- Special Access Surcharge
- Special Access Cross Connect
- Term Payment Plan (TPP) - DS1

These rate categories are described in Sections 7.2.1. (A) through (G) following.

Additionally, rates and charges for Integrated Optical Service Riders may also apply to Special Access connected to Integrated Optical Service Riders as set forth in Section 23.1 following.

The following is Verizon's Open Network Architecture (ONA) Special Access Basic Serving Arrangement which provides a cross-reference to the generic ONA product name.

<u>Generic Name</u>	<u>Telephone Company Name</u>
Dedicated Alert Transport	Alarm Signal Transport Service

The following is a list of the Telephone Company's Open Network Architecture (ONA) Special Access Basic Service Elements (BSEs) which provide a cross-reference to the generic ONA product names.

<u>Generic Name</u>	<u>Telephone Company Name</u>
Automatic Protection Switching	Automatic Loop Transfer
Bridging	Bridging
Conditioning	Conditioning
Multiplexing - Digital 2000	Multiplexing Arrangements

ACCESS SERVICE

7. Special Access Service (Cont'd)

7.2 Rate Categories, Applications and Regulations (Cont'd)

7.2.1 Rate Categories (Cont'd)

(A) Circuit Termination

The Circuit Termination rate category provides for the communications path between a customer designated premises and the serving wire center of that premises. Included as part of the Circuit Termination is a standard channel interface arrangement which defines the technical characteristics associated with the type of facilities to which the access service is to be connected at the Point of Termination (POT) and the type of signaling capability, if any. The signaling capability itself is provided as an optional feature as set forth in (C) following. One Circuit Termination charge applies per customer designated premises at which the circuit is terminated. This charge will apply even if the customer designated premises and the serving wire center are co-located in a Telephone Company building. Connection to Telephone Company provided DS1 or DS3 Circuit Terminations within a serving wire center for customers with EIS will require a Special Access Cross Connect arrangement as described in 7.2.1(F). Circuit Termination rates for DS3 High Capacity Services vary with the number of services and/or level of capacity as set forth in Section 7.2.6 following.

Rates for End User Circuit Terminations are subject to the rules governing Competitive and Non-Competitive Counties as discussed in Section 21.4. Where Competitive and Non-Competitive Rates are present the Circuit Termination consists of two different rate elements: an End User Circuit termination that serves the customer premises and an Interexchange Carrier (IC) Point of Presence (POP) that is collocated in a Company serving wire center. The customer will be charged for both the End User Circuit Termination and the IC Circuit Termination.

(N)
|
(N)

Circuit Mileage

The Circuit Mileage rate category provides for the end office equipment and transmission facilities between serving wire centers and/or Telephone Company hubs. In addition, when Special Access is used in conjunction with Switched Access Service as set forth in 6.3.2 preceding for Switched Access Interface Arrangements*, and the end office serving the customer's end user premises is not a WATS Serving Office, Circuit Mileage is used to extend the Special Access Circuit to a WATS Serving Office. Connection to Telephone Company provided DS1 or DS3 Circuit Mileage within a serving wire center for customers with EIS will require a Special Access Cross Connect arrangement as described in 7.2.1(F). The Circuit Mileage charge is composed of a flat monthly charge plus a rate per mile.

ACCESS SERVICE

7. Special Access Service (Cont'd)

7.2 Rate Categories, Applications and Regulations (Cont'd)

7.2.1 Rate Categories (Cont'd)

(B) Circuit Mileage

The Circuit Mileage rate category provides for the end office equipment and transmission facilities between serving wire centers and/or Telephone Company hubs. In addition, when Special Access is used in conjunction with Switched Access Service as set forth in 6.3.2 preceding for Switched Access Interface Arrangements*, and the end office serving the customer's end user premises is not a WATS Serving Office, Circuit Mileage is used to extend the Special Access Circuit to a WATS Serving Office. Connection to Telephone Company provided DS1 or DS3 Circuit Mileage within a serving wire center for customers with EIS will require a Special Access Cross Connect arrangement as described in 7.2.1(F). The Circuit Mileage charge is composed of a flat monthly charge plus a rate per mile.

DS3 Banded Special transport (as set forth in Section 7.11.5(J) (2) following) provides flat rate transport for certain DS3 bandwidth that is provided under the National Discount Plan. The flat rate transport applies per DS3 service in accordance with Section 22.1.6 following.

* Circuit Mileage for DS1 and DS3 Special Access, when used with Switched Access, is not available for arrangements between service areas listed under 7.1.10.

ACCESS SERVICE

7. Special Access Service (Cont'd)

7.2 Rate Categories, Applications and Regulations (Cont'd)

7.2.1 Rate Categories (Cont'd)

(B) Circuit Mileage (Cont'd)

(1) Fixed Rate

The fixed rate component of Circuit Mileage is applied only once per Circuit Mileage facility. When two or more customer designated premises are served by a common serving wire center (i.e., mileage is zero) the fixed rate component is not applied. Except when served by a common serving wire center, the Circuit Mileage-Fixed charge is applied in full whether the Telephone Company provides one or more than one circuit mileage facility terminations. The Circuit Mileage-Fixed rate does not apply when the Telephone Company provides only an intermediate portion of a circuit mileage facility and no circuit mileage facility terminations. When Special Access is used in conjunction with Switched Access* where the customer's end user premises for the Special Access facility is served by a Telephone Company WATS Serving Office, the fixed rate does not apply.

(2) Per Mile Rate

The mileage to be used to determine the monthly rate for the per mile portion of Circuit Mileage is calculated on the airline distance between the serving wire centers associated with two customer designated premises, between a serving wire center associated with a customer designated premises and a Telephone Company hub, between two Telephone Company hubs, or between a Telephone Company end office and a WATS serving office. The serving wire center associated with a customer designated premises is the serving wire center from which this customer designated premises would normally receive dial tone. The methodology for mileage calculation and serving wire center V&H coordinates are specified in National Exchange Carrier Association Tariff FCC. No. 4. Where the calculated miles include a fraction, the value is always rounded up the next full mile.

* Circuit Mileage for DS1 and DS3 Special Access, when used with Switched Access, is not available for arrangements between service areas listed under 7.1.10.

ACCESS SERVICE

7. Special Access Service (Cont'd)

7.2 Rate Categories, Applications and Regulations (Cont'd)

7.2.1 Rate Categories (Cont'd)

(B) Circuit Mileage (Cont'd)

(2) Per Mile Rate (Cont'd)

When hubs are involved, mileage is computed and rates applied separately for each section of the Circuit Mileage, i.e., customer designated premises serving wire center to hub, hub to hub and/or hub to customer designated premises serving wire center. However, when any service is routed through a hub for purposes other than customer specified bridging or multiplexing (e.g., the Telephone Company chooses to so route for test access purposes), rates will be applied only to the distance calculated between the serving wire centers associated with the customer designated premises.

When more than one Telephone Company is involved in the provision of Special Access Service, the mileage for the per mile component of Circuit Mileage for each Telephone Company is calculated as set forth in 2.4.7 preceding.

(C) Optional Features and Functions

Optional Features and Functions may be added to a basic circuit service to improve its quality or utility to meet the customer's specific communications requirements. These optional features and functions are identifiable with specific equipment, and represent the end result in terms of performance characteristics which may be obtained. These characteristics may be obtained by using various combinations of equipment. Although the equipment necessary to perform a specified function may be installed at various locations along the path of the service, they will be charged for a single rate element.

Descriptions for each of the available Optional Features and functions are set forth in Sections 7.3 through 7.11 following. Specific rate applications for multiplexing are set forth in 7.2.5 following.

ACCESS SERVICE

7. Special Access Service (Cont'd)

7.2 Rate Categories, Applications and Regulations (Cont'd)

7.2.1 Rate Categories (Cont'd)

(D) Nonrecurring Charge

Nonrecurring charges are one-time charges that apply for installation of Special Access Services, installation of optional features and functions, and moves and service rearrangements.

(1) Installation of Service

Nonrecurring charges apply to each service installed. The nonrecurring charges for the installation of service are applied per Circuit Termination.

Two levels of charges apply for the installation of a three or twelve capacity DS3 High Capacity system as set forth in Section 7.2.6 (A) following. A nonrecurring charge applies for the first Circuit Termination ordered by the customer and a separate nonrecurring charge will apply to each additional Circuit Termination to be installed within the same three or twelve capacity system between the same customer locations. For individual noncapacity DS3 service, the nonrecurring charge for each installation will apply at the same rate per DS3 Circuit Termination.

Customers subscribing to the Fractional T1 OPP arrangements, at rates set forth in 7.11.5(A), will not be assessed a nonrecurring charge.

The Regulations in Section 7.2.1(D)(3) will apply to FT1 OPP customers when required for charges and other service rearrangements.

(2) Installation of Optional Features and Functions

Nonrecurring charges apply for the installation of some of the optional features and functions available with Special Access Service. The charge applies whether the feature or function is installed coincident with the initial installation of service or at any time subsequent to the installation of the service.

The optional features for which non-recurring charges apply are:

- Voice Grade Data Capability
- Voice Grade Telephoto Capability
- Program Audio Gain Conditioning
- Program Audio Stereo
- DS3 Premises Multiplexer

ACCESS SERVICE

7. Special Access Service (Cont'd)

7.2 Rate Categories, Applications and Regulations (Cont'd)

7.2.1 Rate Categories (Cont'd)

(D) Nonrecurring Charge (Cont'd)

(3) Service Rearrangements

Service rearrangements are changes to existing (installed) services which may be administrative only in nature, or that involve actual physical change to the service. Changes to pending orders are set forth in 5.3.1 preceding.

Changes in the type of service will be treated as a discontinuance of the service and an installation of a new service.

Changes in the physical location of the point of termination are treated as moves which are described and charged for as in 7.2.1(D)(4).

Changes from a point-to-point DS3 High Capacity Service to a point-to-point DS3 High Capacity Service provided with the DS3 Premises Multiplexer optional feature, as set forth in Section 7.11.4(5) following, are treated as a discontinuance of the service and an installation of a new service.

Changes from a DS3 High Capacity Service multiplexed at a Telephone Company Hub to a point-to-point DS3 High Capacity Service provided with the DS3 Premises Multiplexer optional feature, as set forth in Section 7.11.4(5) following, are treated as a discontinuance of the service and an installation of a new service.

Changes involving the retermination of a Special Access DS1 High Capacity Service from a channel assignment on a DS3 to DS1 multiplexing arrangement at a Telephone Company Hub to a channel assignment on a DS3 Premises Multiplexer, as set forth in Section 7.11.4(5) following, are treated as a discontinuance of the service and an installation of a new service.

(a) Administrative changes will be made without charge(s) to the customer.

ACCESS SERVICE

7. Special Access Service (Cont'd)

7.2 Rate Categories, Applications and Regulations (Cont'd)

7.2.1 Rate Categories (Cont'd)

(D) Nonrecurring Charge (Cont'd)

(3) Service Rearrangements (Cont'd)

- (a) Administrative changes will be made without charge(s) to the customer.

Administrative changes are as follows:

- Change in name or ownership or transfer of responsibility from one customer to another, provided there is no interruption of use or relocation of Special Access service.
- Change of customer or customer's end user premises address when the change of address is not a result of a physical relocation of equipment,
- Change in billing data (name, address, or contact name or telephone number),
- Change of customer circuit identification,
- Change of billing account number,
- Change of customer test line number,
- Change of customer or customer's end user contact name or telephone number,
- Change of agency authorization, and
- Change in jurisdiction involving no physical changes to the service.

ACCESS SERVICE

7. Special Access Service (Cont'd)

7.2 Rate Categories, Applications and Regulations (Cont'd)

7.2.1 Rate Categories (Cont'd)

(D) Nonrecurring Charge (Cont'd)

(3) Service Rearrangements (Cont'd)

(b) All other service rearrangements will be charged for as follows:

- If the change involves the addition of another termination to an existing two-point or multipoint service, installation charges for each location added will apply.
- If the change involves the addition of an optional feature or multiplexing arrangement, the installation charge associated with the optional feature or multiplexing arrangement will apply. When the optional feature or arrangement has no associated nonrecurring charge (or rated at \$.00), one circuit termination nonrecurring charge for the type of service involved (i.e., voicegrade circuit termination, DDS circuit termination, etc.) will be applied to the order.
- If the change involves only changing the type of network interface, with no change in facility, the installation charge associated with each service receiving a network interface change will apply.
- If the change involves changing a two wire service to a four wire service or vice versa, the installation charge for each location changed will apply.

ACCESS SERVICE

7. Special Access Service (Cont'd)

7.2 Rate Categories, Applications and Regulations (Cont'd)

7.2.1 Rate Categories (Cont'd)

(D) Nonrecurring Charge (Cont'd)

(3) Service Rearrangements (Cont'd)

(b) (Cont'd)

- If the change involves only rollovers or grooming, then no charges will apply. A rollover is the retermination of a segment of a lower capacity special access service onto a higher capacity special access service. The rollover must occur in the wire center where the higher capacity service is multiplexed with no other changes to the lower capacity service being reterminated (i.e., the segment must not require rerouting to connect to the multiplexer of the higher capacity service).
- Grooming is the retermination of a lower capacity special access service from one channel in a higher capacity special access service to another channel in the same higher capacity service or to another channel in another higher capacity special access service (i.e., change in connecting facility assignment) in the same wire center, with no other changes to the lower capacity service.

ACCESS SERVICE

7. Special Access Service (Cont'd)

7.2 Rate Categories, Applications and Regulations (Cont'd)

7.2.1 Rate Categories (Cont'd)

(D) Nonrecurring Charge (Cont'd)

(3) Service Rearrangements (Cont'd)

Rollover – Example 1
Current Configuration

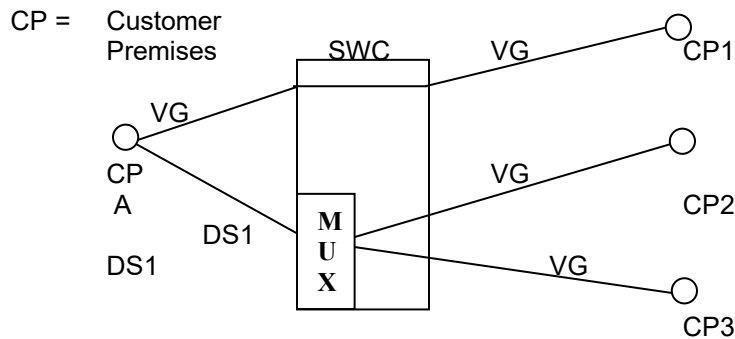

The customer requests that the voiceband circuit (VG) between customer premises A and customer premises 1 be “rolled over” to the DS1 serving customer premises A. No. NRCs apply for this request.

Rollover – Example 1
New Configuration

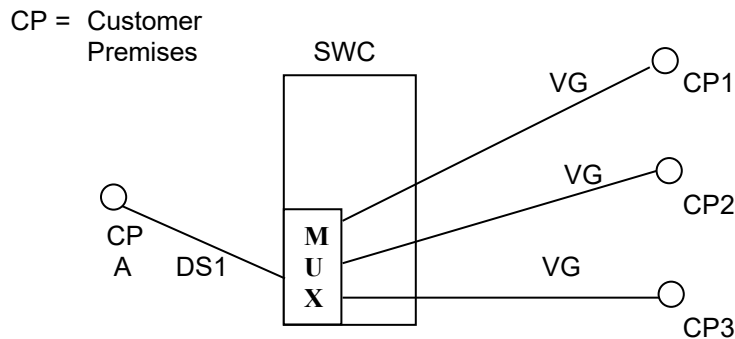

ACCESS SERVICE

7. Special Access Service (Cont'd)

7.2 Rate Categories, Applications and Regulations (Cont'd)

7.2.1 Rate Categories (Cont'd)

(D) Nonrecurring Charge (Cont'd)

(3) Service Rearrangements (Cont'd)

Rollover – Example 2
Current Configuration

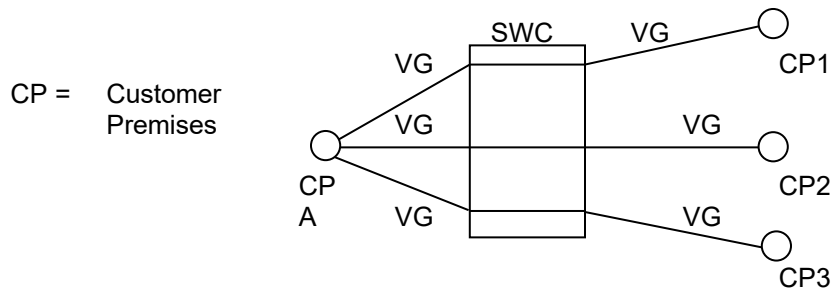

The customer request the installation of DS1 between the serving wire center (SWC) and customer premises A and DS1/Voice multiplexer in the SWC. The customer also request that the voiceband circuits serving customer premises 1,2 and 3 be “rolled over” to the new DS1. All NRCs apply for the installation of the DS1 and multiplexer. No NRCs apply for the voiceband roll overs to the new high capacity circuit.

Rollover – Example 2
New Configuration

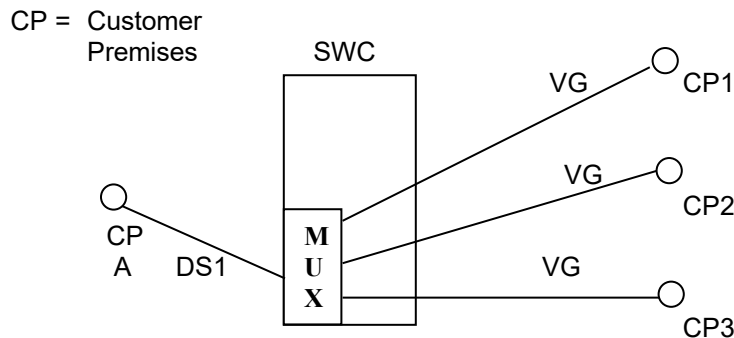

ACCESS SERVICE

7. Special Access Service (Cont'd)

7.2 Rate Categories, Applications and Regulations (Cont'd)

7.2.1 Rate Categories (Cont'd)

(D) Nonrecurring Charge (Cont'd)

(3) Service Rearrangements (Cont'd)

Grooming – Example 1
Current Configuration

CP = Customer Premises

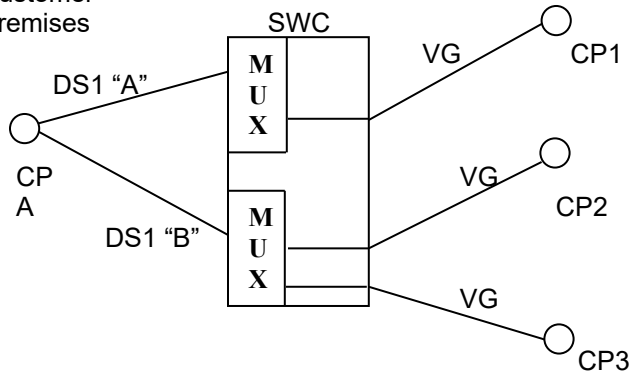

The customer request that the voiceband (VG) circuit serving customer premises 1 be moved from the DS1 "A" circuit to the DS1 "B" circuit. No NRCs apply for this request.

Grooming – Example 1
New Configuration

CP = Customer Premises

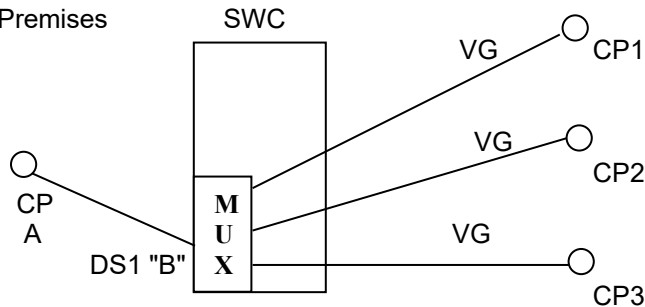

ACCESS SERVICE

7. Special Access Service (Cont'd)

7.2 Rate Categories, Applications and Regulations (Cont'd)

7.2.1 Rate Categories (Cont'd)

(D) Nonrecurring Charge (Cont'd)

(3) Service Rearrangements (Cont'd)

Grooming – Example 2
Current Configuration

CP = Customer
Premises

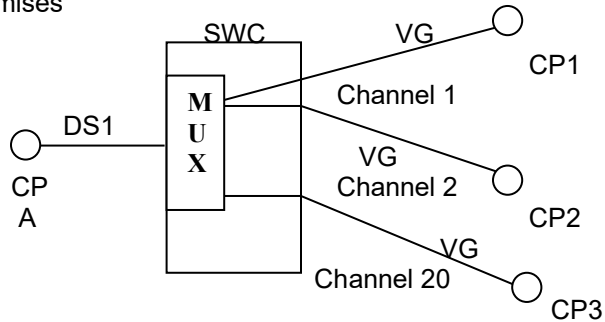

The customer request that the voiceband (VG) circuit serving customer premises 1 be moved from the DS1 "A" circuit to the DS1 "B" circuit. No NRCs apply for this request.

Grooming – Example 2
New Configuration

CP = Customer
Premises

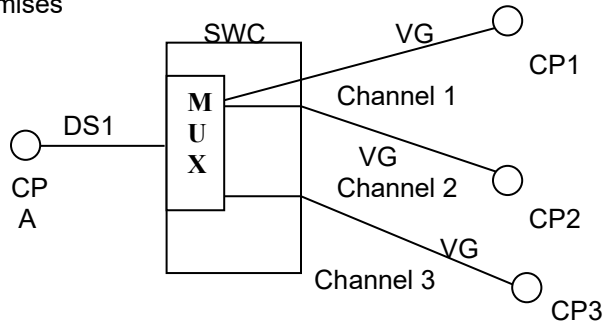

ACCESS SERVICE

7. Special Access Service (Cont'd)

7.2 Rate Categories, Applications and Regulations (Cont'd)

7.2.1 Rate Categories (Cont'd)

(D) Nonrecurring Charge (Cont'd)

(3) Service Rearrangements (Cont'd)

- If the change involves reterminations other than Rollover and/or Grooming, all NRCs associated with the installation of the lower capacity service will apply.
- In cases where multiple service rearrangements or an additional termination or a move and a service rearrangement are requested on a single ASR, the total charge will never exceed the full nonrecurring charge for the basic service.

(4) Moves

A move involves a change in the physical location of the point of termination of Special Access. A move normally involves an interruption of Special Access for the period required to complete the move. No credit allowance will be granted for that period. Special construction may also be applicable at the different customer premises.

A customer may request that Special Access not be interrupted during a move. To comply with that request, it may be necessary to install a duplicate Special Access, and subsequently discontinue the existing Special Access. Charges, monthly and nonrecurring, will apply for the duplicate Special Access. A new minimum period will be established for the duplicate portion of the Special Access, depending on which end of the Special Access is moved. The customer will remain responsible for all minimum period charges associated with the corresponding portion of the disconnected Special Access.

The charge for the move depends on whether the move is within the same customer premises or to a different customer premises.

ACCESS SERVICE

7. Special Access Service (Cont'd)
- 7.2 Rate Categories, Applications and Regulations (Cont'd)
- 7.2.1 Rate Categories (Cont'd)
- (D) Nonrecurring Charge (Cont'd)
- (4) Moves (Cont'd)
- (A) Same CDL
- When the move of a termination, as defined in Section 2.1.5, for special access is to a new point within the same customer premises (same address and/or same building), the charge for the move will be the installation charge for the portion of the service being reterminated. There will be no change in the minimum period requirements. For services subject to payment plan regulations, the same payment period will remain in force.
- (B) Different Customer Premises
- (1) When the move is to a different customer premises (different address and different building), except as specified below, it will be treated as a disconnect and an installation of service. The appropriate service installation charge for the service termination(s) affected will apply. A new minimum period will be established for the installed Special Access Service. The customer will remain responsible for all minimum period charges associated with the disconnected Special Access Service. For services subject to payment plan regulations, a new payment plan will be established and full assessment of the remaining liabilities will be applicable.
- (2) When the move is to a different customer premises but served by the same serving wire center, the following conditions apply:
- A change ASR will be required.
 - The appropriate service installation charge for the service termination(s) affected will apply.
 - For Special Access services subject to payment plan regulations, if the customer of record remains the same with no lapse in service, the appropriate NRCs for changes will apply. Otherwise, the move will be treated as a disconnect and an installation of service and all appropriate NRCs and full assessment of the remaining liabilities will be applicable.
- (5) Disconnect Non-Recurring Charge (C)
- In addition to any other charges associated with discontinuance of services, the Telephone Company will charge a Disconnect Non-Recurring Charge to discontinue services. This charge applies on a per circuit basis as listed in Section 7. In addition to the Disconnect Non-Recurring Charge, minimum service period charges and early termination liability may apply if the circuit term or minimum service period has not been met.

(C)

ACCESS SERVICE

7. Special Access Service (Cont'd)

7.2 Rate Categories, Applications and Regulations (Cont'd)

7.2.1 Rate Categories (Cont'd)

(E) Surcharge for Special Access Service

(1) General

Special Access Services provided under this Guide may be subject to the monthly Special Access Surcharge.

(2) Application

The Special Access Surcharge will apply to each interstate Special Access Service that terminates on an end user's PBX or other device where, through a function of the device, the Special Access Service interconnects to the local exchange network. The Surcharge will apply irrespective of whether the interconnection function is performed in equipment located at the customer's premises or in a Centrex CO-type switch.

The monthly Special Access Surcharge applies to special access facilities on a per voice equivalent basis as shown in the following example:

<u>Special Access Facility</u>	<u>Voice Grade Equivalent</u>	<u>Surcharge</u>	<u>Monthly Charge</u>
Group	12 x	\$25	= \$300.00
DS1	24 x	\$25	= \$600.00

In the case of multipoint special access facilities, one Special Access Surcharge will apply for each termination of a special access circuit at an end user's premises.

The Telephone Company will bill the customer who orders the special access facility the Special Access Surcharge per installation unless the facility is exempt from the surcharge as set forth in (3) following.

When the customer orders DS3 Premises Multiplexer as set forth in Section 7.11.4(5) following, the Special Access Surcharge will apply to the DS1s that are derived from the multiplexer unless written certification is provided in accordance with this Section 7.2.1(E).

ACCESS SERVICE

7. Special Access Service (Cont'd)

7.2 Rate Categories, Applications and Regulations (Cont'd)

7.2.1 Rate Categories (Cont'd)

(E) Surcharge for Special Access Service (Cont'd)

(3) Exemption

The special access facility will be exempted from the monthly surcharge upon receipt of the customer's written certification for the following Special Access Service terminations:

- 1) an open-end termination in a Telephone Company switch of an FX line, including CCSA and CCSA-equivalent ONALs; or
- 2) an analog circuit termination that is used for radio or television program transmission; or
- 3) a termination used for TELEX service; or
- 4) a termination that by the nature of its operating characteristics could not make use of Telephone Company common lines such as terminations which are restricted through hardware or software; or
- 5) a termination that interconnects either directly or indirectly to the local exchange network where the usage is subject to Carrier Common Line charges, such as where the special access facility accesses only FGA and no local exchange lines, or special access facility between customer points of termination, or special access facility connecting CCSA or CCSA-type equipment (inter-machine trunks); or a termination that the customer certifies to the Telephone Company is not connected to a PBX or other device capable of interconnecting the special access facility to a local exchange subscriber line.

Written certification for exemption must include the reason the service is exempted from the surcharge using the categories of exemption as stated above. An ASR may be used for exemption certification, provided all information as required by this section is included. The Telephone Company will bill the surcharge to all customers who have not provided valid exemption certification.

The Telephone Company will cease billing the Special Access Surcharge when certification that the Special Access facility has become exempt from the surcharge, as set forth preceding, is received. If the status of the special access facility was changed prior to the receipt of the exemption certification, the Telephone Company will credit the customer's account, not to exceed ninety days, based on the effective date of the change specified by the customer in the letter of certification.

ACCESS SERVICE

7. Special Access Service (Cont'd)

7.2 Rate Categories, Applications and Regulations (Cont'd)

7.2.1 Rate Categories (Cont'd)

(E) Surcharge for Special Access Service (Cont'd)

(4) Rate

Surcharge for Special Access Service	Monthly <u>Rate</u>
- Applicable to all jurisdictions of the Issuing Carriers listed on Title Pages 2 and 2.1.	
- Per Voice Grade Equivalent	\$25.00

(F) Surcharge for Special Access Service (Cont'd)

The Special Access Cross Connect charge provides the communications path between Telephone Company provided DS0 (DDS operating at 64Kbps or Fractional T1 bandwidths), DS1 or DS3 Circuit Termination or Circuit Mileage and a customer's transmission equipment and facilities where the customer is provided EIS as defined in Section 17. The Special Access Cross Connect charge may also provide the communications path between a customer's transmission equipment and facilities where the customer is provided EIS and EIS arrangements of another customer via Dedicated Transport Service as set forth in Section 19.1. The Special Access Cross Connect is available as DS0, DS1 or DS3 connections. The DS0 Cross Connect can accommodate 64Kbps DDS. The Cross Connect arrangement may be connected directly to Telephone company provided 64Kbps DDS or DS0, DS1 or DS3 services or to a Telephone Company provided 64 Kbps DDS or DS0, DS1, or DS3 multiplexing arrangement located in a Telephone Company Hub. The Cross Connect charge applies per DS0 (64Kbps), DS1, or DS3 connection.

In addition to the Special Access Cross Connect arrangements described herein, Optical Facility Terminations are available as described in Section 19.2.

Rates for DS0, DS1, and DS3 Cross Connect arrangements listed in Section 7.11.5 and rates for Optical Facility Terminations listed in Section 19.2(E) will apply in addition to the other rates and charges as specified in Section 17.

ACCESS SERVICE

7. Special Access Service (Cont'd)

7.2 Rate Categories, Applications and Regulations (Cont'd)

7.2.1 Rate Categories (Cont'd)

(G) DS1 Term Payment Plan (TPP)#

(1) Description

The DS1 Term Payment Plan (TPP) allows customers term discounts for DS1 circuit termination. A customer may select this service for either a single state or multi state level. TPP is offered for a 1, 2, 3, or 5 year service commitment period for the DS1 circuit termination. All TPP DS1 circuit terminations will be billed the same rate, depending on the length of the term selected by the customer.

During the TPP term, a customer may not concurrently subscribe its Special Access DS1 Services to a National Discount Plan as set forth in Section 22 following.

(2) Rate Changes

Decreases in the TPP monthly recurring circuit termination rates will be passed on to subscribers of the plan.

Effective November 21, 2017, new subscriptions to DS1 Term Payment Plan are no longer permitted. DS1 TPP customers subscribed as of November 16, 2017 may continue with their existing subscriptions. If at any time an existing customer terminates its DS1 TPP, the customer may not re-subscribe to the plan.

ACCESS SERVICE

7. Special Access Service (Cont'd)

7.2 Rate Categories, Applications and Regulations (Cont'd)

7.2.1 Rate Categories (Cont'd)

(G) DS1 Term Payment Plan (TPP)# (Cont'd)

(3) Commitment Levels

To initiate a TPP, on either a single state or multi state plan, the minimum commitment is as shown below.

<u>Number of States</u>	<u>Minimum Number of Circuit Terminations</u>
1	25
2	50
3	75
4	100
5 and over	125

The commitment levels will be met if the customer has the minimum number of DS1 TPP circuit terminations in service. If the customer has committed to more than the minimum number of circuit terminations required, as shown above, an allowance of minus 2% or plus 5 % will be considered as having met the commitment level. If the customer disconnects service under its DS1 TPP in order to replace it with a Replacing Service pursuant to Section 2.9 preceding, the terms and conditions for a Technology Migration as set forth in Section 2.9 preceding apply, including the calculation affecting the Annual Review as set forth in Section 2.9.1 preceding.

(4) Changes to Commitment Levels

Written notice must be submitted by the customer to change the commitment level of DS1 circuit terminations. If, as the result of increasing or decreasing the commitment level, service is changed from a TPP to a DS1 standard arrangement, or from a standard arrangement to a TPP arrangement an ASR will be required within 30 days for all services changed. Only one TPP arrangement will be allowed per customer for each term period. Penalties for decreasing the commitment level are discussed in 7.2.1(G)(8).

Service Availability is limited. Refer to # footnote on page 7-30.

ACCESS SERVICE

7. Special Access Service (Cont'd)

7.2 Rate Categories, Applications and Regulations (Cont'd)

7.2.1 Rate Categories (Cont'd)

(G) DS1 Term Payment Plan (TPP)# (Cont'd)

(5) TPP Plan Enrollment

When the customer elects to enroll in a TPP they must specify, in writing, the enrollment date (which will be the anniversary date) and the commitment level. The specified enrollment date must be within 30 days of receipt. The customer must also select whether the TPP will be a single state or multi-state plan and specify the states to be included. By the specified date the customer must issue ASRs to add DS1 circuit terminations to the TPP and/or convert standard arrangement to the TPP to fall within the commitment range specified in 7.2.1(G)(3).

(6) Annual Review

Each customer's TPP will be reviewed annually to determine if the customer met its commitment of TPP DS1 circuit terminations (including any DS1 circuit terminations that were replaced by a Replacing Service using the methodology for a Technology Migration specified in Section 2.9.1 preceding). The customer will be notified in writing as to the status of the TPP. This notification will inform the customer of any TPP DS1 circuit terminations that must be converted. If the customer has increased the number of DS1 circuit terminations from the initial commitment beyond the range specified in 7.2.1(G)(3), he will have the option of increasing the commitment level for the remainder of the plan. If the customer chooses not to increase the commitment level of DS1 circuit terminations for the remaining year(s) of the plan, he must convert the increased number of DS1 circuit terminations to the standard payment plan. The DS1 circuit terminations that are converted to the standard payment plan will not be eligible for reconversion to the TPP for a ten month period. The customer may decrease the commitment level at the time of the annual review and pay the applicable penalties for the amount of DS1 circuit terminations being decreased. The customer will have 30 days from receipt of this notification to convert DS1 circuit terminations.

If the customer does not take action during the 30 day period, the commitment level will be automatically changed to the number of TPP DS1 circuit terminations in effect at the anniversary date. Penalties will apply as set forth in 7.2.1(G)(8).

Service Availability is limited. Refer to # footnote on page 7-30.

ACCESS SERVICE

7. Special Access Service (Cont'd)

7.2 Rate Categories, Applications and Regulations (Cont'd)

7.2.1 Rate Categories (Cont'd)

(G) DS1 Term Payment Plan (TPP)# (Cont'd)

(7) TPP Conditions

If a DS1 service has two DS1 circuit terminations, to include this service as part of a TPP, both DS1 circuit terminations must be in the TPP.

After enrolling in the plan, the customer may add or delete DS1 circuit terminations rated at the specified term period rate at any time during the plan. For example, if the customer agrees to a 2 year TPP, they may add DS1 circuit terminations at any time at the 2 year TPP rate.

Individual states can not be added or deleted during the plan period.

A customer may subscribe to only one plan for each term period within a given state.

(8) Penalties for Failing To Meet Commitment

When the number of TPP Services at the annual review is less than the acceptable commitment range, the following penalty charges will apply, based on the difference between the commitment level less 2% and the number of TPP services in effect at the annual review. For example, if the commitment level is 100 and the customer has 90 DS1 TPP circuit terminations at time of annual review, the penalties described below will be applied to the difference of 98 (2% less than 100) and 90, which would be 8 in this example.

(a) The penalties charged during the first year of the TPP will be the full MRC for 4 months plus 10% of the MRC for the remaining number of months.

(b) The penalties charged during the subsequent years of the TPP will be 10% of the MRC for 4 months plus 10% of the MRC for the remaining number of months.

Service Availability is limited. Refer to # footnote on page 7-30.

ACCESS SERVICE

7. Special Access Service (Cont'd)

7.2 Rate Categories, Applications and Regulations (Cont'd)

7.2.1 Rate Categories (Cont'd)

(G) DS1 Term Payment Plan (TPP)# (Cont'd)

(9) TPP Nonrecurring Charge

Customers subscribing to a TPP will be assessed a nonrecurring charge per circuit termination except in the following conditions:

- when converting standard arrangement circuit terminations to a TPP.

(10) Changes in Length of a TPP Period

Prior to the expiration of a TPP period, the customer may elect to convert to a new TPP period of the same or different length, subject to the following conditions:

- no credit will be given for the new payment period for payments made under the original TPP arrangement
- NRCs will not be reapplied for existing service(s)
- if the new TPP period is shorter in length than the time remaining under the existing TPP, the change to the new TPP period constitutes a disconnect of the existing TPP service and termination liability charges will apply
- the rates for the new period will be the rates currently in effect at the time of the change.

Service Availability is limited. Refer to # footnote on page 7-30.

ACCESS SERVICE

7. Special Access Service (Cont'd)

7.2 Rate Categories, Applications and Regulations (Cont'd)

7.2.1 Rate Categories (Cont'd)

(G) DS1 Term Payment Plan (TPP)# (Cont'd)

(11) Renewal Options

At the expiration of a TPP period, the customer may select a new TPP period or convert to a month to month payment plan. If the customer fails to make this selection, the Telephone Company will notify the customer and continue one additional month of TPP billing. If the customer does not select a new payment plan within 30 days from the expiration date, billing will automatically convert to the DS1 month to month payment plan.

At the expiration of the TPP period, if the customer renews at the DS1 quantity in service at the end of his previous TPP, or a greater quantity, and makes no change in the selected states, then any penalties that may need to be assessed at the first anniversary of the renewal period will be assessed as set forth in 7.2.1(G)(8)(b). The rates for the renewal period will be the rates in effect at the time of the renewal.

(12) Upgrade to Higher Speed Service

The customer may upgrade service to a higher speed during a TPP period. The upgraded service will be subject to all appropriate NRCs.

If both of the following conditions exist, the commitment level will be decreased by the number of TPP DS1 circuit terminations that are upgraded to a higher speed service.

- The customer must notify the Telephone Company in writing in addition to the ASR.
- The higher speed service period must be longer in length than the time remaining under the TPP.

Service Availability is limited. Refer to # footnote on page 7-30.

ACCESS SERVICE

7. Special Access Service (Cont'd)

7.2 Rate Categories, Applications and Regulations (Cont'd)

7.2.1 Rate Categories (Cont'd)

(G) DS1 Term Payment Plan (TPP)# (Cont'd)

(13) Technology Migrations

For customers who subscribe to or renew their subscription to a DS1 TPP on or after December 2, 2010, the customer may disconnect a DS1 Circuit Termination included in the DS1 TPP in order to replace such DS1 Circuit Termination with a Replacing Service pursuant to Section 2.9 preceding.

For customers who subscribed to a DS1 TPP prior to December 2, 2010, Section 7.2.1(G)(12) preceding includes replacements of DS1 Circuit Terminations with Telephone Company provided Ethernet private line service or a Telephone Company provided switched Ethernet service of a higher speed. However, the customer may, at its option, replace a DS1 Circuit Termination with a Replacing Service pursuant to Section 2.9 preceding in lieu of Section 7.2.1(G)(12) preceding.

Service Availability is limited. Refer to # footnote on page 7-30.

ACCESS SERVICE

7. Special Access Service (Cont'd)

7.2 Rate Categories, Applications and Regulations (Cont'd)

7.2.2 Minimum Periods

The minimum service period for all services except part-time and occasional Program Audio services and High Capacity DS3 services is one month. The minimum service period for part-time Program Audio Services is one day even though the service will be provided only for the duration of the event specified on the order (e.g., one-half hour, two hours, five hours, etc.). The minimum period for High Capacity DS3 Service is that period requested by the customer as set forth in Section 7.2.6 (B) following. The minimum period for Month to Month Rated DS3 Service is 12 months.

(C)
(C)

The minimum service periods for High Capacity DS3 Services and High Capacity DS1 Services that are included in a National Discount Plan are set forth in Section 22.1.8 following.

7.2.3. Application of Daily and Monthly Rates

(A) Daily Rates

Daily rates are recurring rates that apply to each 24 hour period or fraction thereof that a Program Audio Special Access Service is provided for part-time or occasional use. For purposes of applying daily rates, the 24 hour period is not limited to a calendar day.

Part-time Program Audio Service ordered on one Access Service Request and provided within a consecutive 30 day period will be charged the daily rate, not to exceed an amount equal to the monthly rate. For each subsequent day or part day, a charge equal to 1/30th of the monthly rate shall apply.

(B) Monthly Rates

Monthly rates are flat recurring rates that apply each month or fraction thereof that a Special Access Service is provided. For billing purposes, each month is considered to have 30 days.

ACCESS SERVICE

7. Special Access Service (Cont'd)

7.2 Rate Categories, Applications and Regulations (Cont'd)

7.2.4 Facility Hubs and Multiplexing

A customer has the option of ordering Voice Grade facilities or High Capacity facilities (i.e., DS1, DS2, DS3 or DS4) to a facility hub for multiplexing to individual services of a lower capacity or bandwidth (e.g., Voice, Program Audio, etc.). Additionally, the customer may specify optional features for the individual circuits derived from the facility to further tailor the circuit to meet specific communications requirements.

Some of the types of multiplexing available include the following:

- from higher to lower bit rate
- from higher to lower bandwidth
- from digital to voice frequency circuits

A hub is a Telephone Company designated wire center at which multiplexing functions are performed.

Different locations may be designated as hubs for different facility capacities, e.g., multiplexing from digital to digital may occur at one location while multiplexing from digital to analog may occur at a different location. When placing an Access Service Request the customer will specify the desired hub. The National Exchange Carrier Association Tariff FCC No. 4 identifies serving wire centers, hub locations and the type of multiplexing functions available.

When a DS3 High Capacity Service is multiplexed at a customer designated premises, such configuration is not a Telephone Company Hub for purposes of administering the terms and conditions of this Guide.

For DS3 High Capacity Service, multiplexing functions may also be performed at a customer designated premises using the DS3 Premises Multiplexer optional feature set forth in Section 7.11.4(5) following.

ACCESS SERVICE

7. Special Access Service (Cont'd)

7.2 Rate Categories, Applications and Regulations (Cont'd)

7.2.4 Facility Hubs and Multiplexing (Cont'd)

Point to point services may be provided on circuits of these facilities to a hub. The transmission performance for the point to point service provided between the customer designated premises will be that of the lower capacity or bit rate.

The Telephone Company will commence billing the monthly rate for the facility to the hub on the date specified by the customer on the Access Service Request. The customer will be billed for a High Capacity or Voice Grade Circuit Termination, Circuit Mileage, Special Access Cross Connect and the multiplexer for the service at the time the facility is installed. Individual services utilizing these facilities may be installed coincident with the installation of the facility to the hub or may be ordered and/or installed at a later date, at the option of the customer. Individual service rates (by service type) will apply for a Circuit Termination and additional Circuit Mileage (as required) for each channelized service. These will be billed to the customer as each individual service is installed.

Cascading multiplexing occurs when a high capacity circuit is de-multiplexed to provide circuits with a lesser capacity and one of the lesser capacity circuits is further demultiplexed. When cascading multiplexing is performed, whether in the same or a different hub, a charge for the additional multiplexing unit also applies. When cascading multiplexing is performed at different hubbing locations, Circuit Mileage charges also apply between the hubs.

Although not requiring multiplexing, the Telephone Company will designate certain hubs for Program Audio Services. Full-time service will be provided between a customer designated premises and a hub and billed accordingly at the monthly rates set forth in 7.6.5 and 7.7.4 for a Circuit Termination, and Circuit Mileage and Optional Features and Functions as applicable. The customer may order part-time and occasional Program Audio as needed between the hub and a second customer designated premises. The rate elements required to provide the part-time or occasional service (i.e., Circuit Termination, and Circuit Mileage and Optional Features as applicable) will be billed at daily rates for the duration of the service requested.

ACCESS SERVICE

7. Special Access Service (Cont'd)

7.2 Rate Categories, Applications and Regulations (Cont'd)

7.2.5 Shared Use Analog and Digital High Capacity Services

(T)

Shared Use refers to a rate application applicable only when the customer orders High Capacity Special Access facilities between a customer designated premises and a Telephone Company hub where the Telephone Company performs multiplexing/de-multiplexing functions and the same customer then orders the derived channels as Special and Switched Access Services. If the customer has Switched Access Service between a customer designated premises and an end office that is multiplexed at a Telephone Company hub and subsequently orders the derived channels as Special and Switched Access Service, rates and charges will apply as if the service were ordered as shared use.

Shared use of Special Access Cross Connect and Expanded Interconnection service are not available.

Except as noted above, the High Capacity facility will be ordered, provided and rated as Special Access Service (i.e., Channel Termination, Channel Mileage, as appropriate, and Multiplexing Arrangement). The nonrecurring charge that applies when the shared use facility is installed will be the nonrecurring charge associated with the appropriate Special Access High Capacity Channel Termination. Rating as Special Access will continue until such time as the customer chooses to use a portion of the available capacity for Switched Access Service. Individual service (i.e., Switched or Special Access) nonrecurring charges will not apply to the individual channels of the shared use facility.

When Special Access Service is provided utilizing a channel of the shared use facility to a hub, High Capacity rates and charges will apply for the facility to the hub, as set forth preceding, and individual service rates and charges will apply from the hub to the customer designated premises. The rates and charges that will apply to the portion from the hub to the customer designated premises will be dependent on the specific type of Special Access Service that is provided. The applicable rates and charges will include a Channel Termination and Channel Mileage, if applicable. Rates and charges for optional features and functions associated with the service, if any, will apply for the appropriate channel type.

(T)

* Shared Use Analog and Digital High Capacity Services, are not available for arrangements between service areas listed under 7.1.10.

ACCESS SERVICE

7. Special Access Service (Cont'd)

7.2 Rate Categories, Applications and Regulations (Cont'd)

7.2.5 Shared Use Analog and Digital High Capacity Services (Cont'd)

(T)

As each individual channel is activated for Switched Access Service, the High Capacity Special Access Channel Termination, Channel Mileage, and Multiplexing rates will be reduced accordingly (e.g., 1/24th for a DS1 service, etc.). Switched Access Service rates and charges, as set forth in FCC 13 Section 20 following, will apply for each channel that is used to provide a Switched Access Service. Additionally, the Switched Access Service Entrance Facility, Direct Trunked Transport, and Multiplexing charges, if applicable, will be reduced by multiplying their respective rates by the ratio of derived Switched Access Service channels to the total number of Voice Grade channels that can be derived.

The customer must place an order for each individual Switched or Special Access Services utilizing the Shared Use Facilities and specify the channel assignment for each such service.

(T)

ACCESS SERVICE

7. Special Access Service (Cont'd)

7.2 Rate Categories, Applications and Regulations (Cont'd)

7.2.6 DS3 High Capacity*

- (A) A DS3 (44.736Mbps) High Capacity Circuit Termination may be ordered as an Individual, 3-System or 12-System. A Circuit Termination may be ordered with an electrical or optical interface.

DS3 Circuit Terminations are non-distance sensitive and are provided on a protected basis.

Individual System

An Individual System is a single DS3 between a CDL and the serving wire center. The appropriate NRC is applied per Circuit Termination.

Circuit Mileage rate elements are applied per Circuit Termination when mileage between offices is required. In instances when a Circuit Termination is ordered to a second CDL in conjunction with an Individual System Circuit Termination and Circuit Mileage between offices is required Circuit Mileage rate elements are applied per circuit.

Banded Circuit Mileage rate elements are applied to certain DS3 Services that are provided under a National Discount Plan as specified in Section 22.1.6 following.

* DS3 High Capacity service may be provided between service areas shown under 7.1.10, where facilities and conditions permit.

ACCESS SERVICE

7. Special Access Service (Cont'd)

7.2 Rate Categories, Applications and Regulations (Cont'd)

7.2.6 DS3 High Capacity (Cont'd)

(A) (Cont'd)

3-System#

(T)

The 3-System allows the same customer, between the same CDL and the serving wire center, to order additional DS3 Circuit Terminations, up to a maximum of two. Additional Circuit Terminations may only be added with the same interface, electrical or optical, as the First System. The appropriate NRC is applied per Circuit Termination.

Circuit Mileage rate elements are applied per Circuit Termination when mileage between offices is required. In instances when a Circuit Termination is ordered to a second CDL in conjunction with a 3-System Circuit Termination and Circuit Mileage between offices is required Circuit Mileage rate elements are applied per circuit.

Banded Circuit Mileage rate elements are applied to certain DS3 Services that are provided under a National Discount Plan as specified in Section 22.1.6 following.

12-System#

(T)

The 12-System allows the same customer, between the same CDL and the serving wire center, to order additional DS3 Circuit Terminations, with a maximum of eleven. Additional Circuit Terminations may only be added with the same interface, electrical or optical, as the First System. The appropriate NRC is applied per Circuit Termination.

Circuit Mileage rate elements are applied per Circuit Termination when mileage between offices is required. In instances when a Circuit Termination is ordered to a second CDL in conjunction with a 12-System Circuit Termination and Circuit Mileage between offices is required Circuit Mileage rate elements are applied per circuit in accordance with Section 7.2.1(B).

Banded Circuit Mileage rate elements are applied to certain DS3 Services that are provided under a National Discount Plan as specified in Section 22.1.6 following

Effective November 21, 2017, new subscriptions to DS3 3-System and DS3 12-System are no longer permitted. DS3 3-System and DS3 12-System customers subscribed as of November 16, 2017 may continue with their existing subscriptions. If at any time an existing customer terminates its DS3 3-System and DS3 12-System, the customer may not re-subscribe to the plan.

ACCESS SERVICE

7. Special Access Service (Cont'd)

7.2 Rate Categories, Applications and Regulations (Cont'd)

7.2.6 DS3 High Capacity (Cont'd)

(B) Service Periods #

DS3 service is offered under four service periods, each with different rate levels. The service periods are 1, 3, 5 and 7 years. The customer must specify the service period at the time the service is ordered. Each DS3 service within a three/twelve capacity system can have a different service period. Each DS3 Circuit Termination of a two-point DS3 service must have the same service period.

(C) Expiration of Service Periods ##

(C)

At expiration of the service commitment period the service will convert to the *the* Individual DS3 – Non-Capacity System Month to Month rate.

Effective November 19, 2021 DS3 Service Periods are no longer permitted. DS3 Service Period rates in effect as of November 19, 2021 may continue the existing term but will not be eligible to extend, renew, reenroll in, convert to a new term period, or in any other way continue their existing plan beyond its current expiration. At expiration of the commitment term service will be converted to the Month to Month Rate. If at any time an existing customer terminates its DS3 Service Period the customer may not re-subscribe to the rate.

Effective July 26, 2022 any DS3 Service billing at the Month to Month rate will convert to the Individual DS3 – Non-Capacity System Month to Month rate. In addition, at the expiration of a Service Period, the DS3 service will convert to the Individual DS3 – Non-Capacity System Month to Month rate.

(N)

ACCESS SERVICE

7. Special Access Service (Cont'd)

7.2 Rate Categories, Applications and Regulations (Cont'd)

7.2.6 DS3 High Capacity (Cont'd)

(D) Discontinuance Without Liability - DS3 Service Periods #, ##

Reserved for Future Use

(C)

The customer may cancel the service period of a DS3 Service that is provided under this Section 7.2.6 in order to subscribe such DS3 Service to the NDP as set forth in Section 22 following.

The customer may cancel the service period of a DS3 Service that is provided under this Section 7.2.6 in order to replace the DS3 Service with a Replacing Service pursuant to the Technology Migration regulations set forth in Section 2.9 preceding.

Service Offer is limited. See footnote on page 7-44

Service offer is further limited. See footnote on page 7-44

ACCESS SERVICE

7. Special Access Service (Cont'd)

7.2 Rate Categories, Applications and Regulations (Cont'd)

7.2.6 DS3 High Capacity (Cont'd)

(E) Discontinuance With Liability - DS3 Service Periods #, ## (C)

When a DS3 service is discontinued prior to the end of the service period, the customer will be liable for a percentage of the total monthly charges for the remaining portion of the service period. This charge will be based on the rates in effect at the time of disconnect. The customer's total liability is dependant upon the number of months remaining within the year that the service is discontinued times the liability rate for that year plus the total monthly charges for each annual period remaining in the service period times the applicable liability rate. The liability rates for each year of the service period are as follows:

<u>Year In Which Service Is Discontinued</u>	<u>Liability Rate</u>
1	45%
2	30%
3	25%
4	20%
5	15%
6	10%
7	5%

For example, if a customer with a seven year service period discontinues DS3 service after six months within the 4th year, the customer will be liable for 20% of the total monthly charges for six months, 15% of the total monthly charges for the 5th year, 10% of the total monthly charges for the 6th year and 5% of the total monthly charges for the 7th year.

(x) Reissued material originally filed under Transmittal No. 1118 on November 15, 2010, and scheduled to become effective November 30, 2010.

(F) Reserved for Future Use

Service Offer is limited. See footnote on page 7-44

Service Offer is further limited. See footnote on page 7-44. (N)

ACCESS SERVICE

7. Special Access Service (Cont'd)

7.2 Rate Categories, Applications and Regulations (Cont'd)

7.2.6 DS3 High Capacity (Cont'd)

(G) Upgrades

(1) Upgrade to a Larger Capacity System #, ##

(C)

At the customer's option, upgrades from a smaller capacity system to a larger capacity system will be allowed. All appropriate NRCs for the larger capacity system will apply. Credit will not be given for any number of months the original system was maintained. The larger capacity system requires the Individual DS3 – Non-Capacity System Month to Month rate. A new minimum period will be required for the larger capacity system.

(2) Technology Migration

A customer subscribing to DS3 High Capacity Service under a minimum service period may disconnect such DS3 High Capacity Service in order to replace it with a Replacing Service pursuant to the Technology Migration regulations set forth in Section 2.9 preceding.

(C)

(H) Downgrade to a Smaller Capacity System #, ##

Downgrades from a larger capacity system to a smaller capacity system will not be allowed without the full assessment of the liabilities described in (E) preceding for the original larger system, plus the full application of all charges for the smaller system. Credit will not be given for any number of months the original system was maintained. The smaller capacity system requires the Individual DS3 – Non-Capacity System Month to Month rate. A new minimum period will be required for the smaller capacity system.

(I) Service Disconnect

When a customer requests the disconnect of a DS3 service in the three/twelve capacity system, the disconnect steps are applied on a last in, first out basis. When only the First DS3 service exists on a three/twelve capacity system, that service will be disconnected.

Service Offer is limited. See footnote on page 7-44

Service Offer is further limited. See footnote on page 7-44

(N)

ACCESS SERVICE

7. Special Access Service (Cont'd)

7.3 Reserved for Future Use

7.4 Reserved for Future Use

7.5 Voice Grade Service

7.5.1 Basic Circuit Description

A Voice Grade Circuit is a circuit which provides voice frequency transmission capability in the nominal frequency range of 300 to 3000 Hz and may be terminated two-wire or four-wire. Effective 2-wire and 4-wire circuits are available as an Optional Feature and Function. Voice Grade circuits are provided between customer designated premises or between a customer designated premises and a Telephone Company hub.

Voice Grade Service may be ordered in conjunction with Switched Access services as set forth in Section 6.3.2 preceding to provide access for a customer's communications service (e.g., WATS, 800, 888, or WATS-type service). When the customer orders the Switched Access Interface Arrangement, Voice Grade Circuits provide voice frequency transmission capability between an end user premises and a WATS Serving Office (WSO). All applicable Special Access rates and charges apply (including Optional Features and Functions charges). Technical Specifications and Optional Features and Functions available with this arrangement are indicated under Package VG-SI in 7.5.5 following.

ACCESS SERVICE

7. Special Access Service (Cont'd)

7.5 Voice Grade Service (Cont'd)

7.5.2 Technical Specifications Packages

Parameter	C*	Package VG-												SI		
		1	2	3	4	5	6	7	8	9	10	11	12			
Attenuation																
Distortion	X	X	X	X	X	X	X	X	X	X	X	X	X	X	X	X
C-Message Noise	X	X	X	X	X	X	X	X	X	X	X	X	X	X	X	X
Echo Control	X	X	X	X		X		X	X		X	X	X	X		
Envelope Delay																
Distortion	X					X	X	X	X	X	X	X	X	X	X	X
Frequency Shift	X					X	X	X	X	X	X	X	X	X	X	X
Impulse Noise	X				X	X	X	X	X	X	X	X	X	X	X	X
Intermodulation																
Distortion	X					X	X	X	X	X	X	X	X	X	X	X
Loss Deviation	X	X	X	X	X	X	X	X	X	X	X	X	X	X	X	X
Phase Hits, Gain																
Hits, and Dropouts	X															
Phase Jitter	X					X	X	X	X	X	X	X	X	X	X	X
Return Loss																X
Signal-to-C																
Message Noise					X											
Signal-to-C																
Notch Noise	X				X	X	X	X	X	X	X	X	X	X	X	X

The technical specifications for these parameters (except for dropouts, gain hits, and phase hits) are delineated in Technical Reference TR-NWT-000335, Issue 3, and associated Addendum. The technical specifications for dropouts, phase hits, and gain hits are delineated in Technical Reference PUB 41004, Table 4.

* The desired parameters are selected by the customer from the list of available parameters.

ACCESS SERVICE

7. Special Access Service (Cont'd)

7.5 Voice Grade Service (Cont'd)

7.5.3 Channel Interfaces

The following channel interfaces for Voice Grade service do not require signaling capability: AH, DA, DB, DD, DE DS, NO, PR and TF.

The following channel interfaces for Voice Grade service require signaling capability: AB, AC, CT, DX, DY, EA, EB, EC, EX, GO, GS, LA, LB, LC, LO, LR, LS, RV, and SF.

Compatible channel interfaces are set forth in 9. following.

7.5.4 Optional Features and Functions

(1) Central Office Bridging Capability

- (a) Voice Bridging (two-wire or four-wire)
- (b) Data Bridging (two-wire or four-wire)
- (c) Telephoto Bridging (two-wire and four-wire)
- (d) Dataphone Select-A-Station Bridging with sequential arrangement ports or addressable arrangement ports
- (e) Telemetry and Alarm Bridging, Split Band-Active Bridging, Passive Bridging, Summation-Active Bridging

(2) Reserved for Future Use

(3) Conditioning

Conditioning provides more specific transmission characteristics for Voice Grade services. C-Type conditioning controls attenuation distortion and envelope delay distortion. Sealing Current helps maintain continuity on dry metallic loops.

For two-point services, the parameters apply to each service. For multipoint services, the parameters apply to each mid link or end link. C-Type conditioning and Data Capability may be combined on the same service.

ACCESS SERVICE

7. Special Access Service (Cont'd)

7.5 Voice Grade Service (Cont'd)

7.5.4 Optional Features and Functions (Cont'd)

(3) Conditioning (Cont'd)

(a) C-Type Conditioning

C-Type Conditioning is provided for the additional control of attenuation distortion and envelope delay distortion on data services. The attenuation distortion and envelope delay distortion specifications for C-Type Conditioning are delineated in Technical Reference TR-NWT-000335, Issue 3.

(b) Improved C-Type Conditioning

Improved C-Type Conditioning options are provided in conjunction with C-Type Conditioning at the rates set forth in Section 7.5.5 following. The C-Type Conditioning rate shall apply only once regardless if one or both of the following Improved Options are ordered.

(i) Improved Attenuation Distortion

Improved Attenuation Distortion upgrades the frequency versus loss limits of the channel. The technical specifications for Improved Attenuation Distortion are delineated in Technical Reference TR-NWT-000335, Issue 3. This option is provided in conjunction with C-Type conditioning.

(ii) Improved Envelope Delay Distortion

Improved Envelope Delay Distortion upgrades the frequency versus delay response limits of the channel. The technical specifications for Improved Envelope Delay Distortion are delineated in Technical Reference TR-NWT-000335, Issue 3. This option is provided in conjunction with C-Type conditioning.

(c) Sealing Current

Sealing Current Conditioning is provided to help maintain continuity on dry metallic loops. It is usually associated with four-wire DA or NO type channel interfaces.

ACCESS SERVICE

7. Special Access Service (Cont'd)

7.5 Voice Grade Service (Cont'd)

7.5.4 Optional Features and Functions (Cont'd)

(4) Customer Specified Premises Receive Level

This option allows the customer to specify the receive level at the Point of Termination. This level must be within a specific range on effective four-wire transmission. The ranges are delineated in Technical Reference TR-NWT-000335, Issue 3.

(5) Improved Return Loss

(a) On Effective Four-Wire Transmission at Four-Wire Point of Termination (applicable to each two-wire port): Provides for a fixed 600 ohm impedance, variable level range and simplex reversal. Telephone Company equipment is required at the customer's premises where this option is ordered. The Improved Return Loss parameters are delineated in Technical Reference TR-NWT-000335, Issue 3.

(b) On Effective Four-Wire Transmission at Two-Wire Point of Termination: Provides for more stringent Echo Control specifications. In order for this option to be applicable, the transmission path must be four-wire at one POT and two-wire at the other POT. Placement of Telephone Company equipment may be required at the customer's premises with the two-wire POT. The Improved Return Loss parameters are delineated in Technical Reference TR-NWT-000335, Issue 3.

ACCESS SERVICE

7. Special Access Service (Cont'd)

7.5 Voice Grade Service (Cont'd)

7.5.4 Optional Features and Functions (Cont'd)

(6) Data Capability

Data Capability provides transmission characteristics suitable for data communications. Specifically, Data Capability provides for the control of Signal to C-Notched Noise Ratio and intermodulation distortion. It is available for two-point services or multipoint services.

The Signal to C-Notched Noise Ratio and intermodulation distortion parameter for Data Capability are:

- Signal to C-Notched Noise Ratio is greater than or equal to 32dB Intermodulation distortion
- Signal to second order modulation products (R2) is greater than or equal to 38dB
- Signal to third order modulation products (R3) is greater than or equal to 42 dB

When a service equipped with Data Capability is used for voice communications, the quality of the voice transmission may not be satisfactory.

(7) Telephoto Capability

Telephoto Capability provides transmission characteristics suitable for telephotographic communications. Specifically, Telephoto Capability is provided for the control of attenuation distortion and envelope delay distortion of telephotographic services. The attenuation distortion and envelope delay distortion parameters for Telephoto Capability are:

<u>Attenuation Distortion</u> (1004Hz Reference)		<u>Envelope Delay Distortion</u>	
<u>Frequency Range (Hz)</u>	<u>Variation (dB)</u>	<u>Frequency Range (Hz)</u>	<u>Variation (mcs)</u>
500-3000	-0.5 to +1.5	1000-2600	110
300-3200	-1.0 to +2.5	800-2800	180

ACCESS SERVICE

7. Special Access Service (Cont'd)

7.5 Voice Grade Service (Cont'd)

7.5.4 Optional Features and Functions (Cont'd)

(8) Signaling Capability

Signaling Capability provides for the ability to transmit signals from one customer premises to another customer premises on the same service.

(9) Selective Signaling Arrangement

An arrangement that permits code selective ringing for up to ten codes on a multipoint service.

(10) Transfer Arrangement

An arrangement that affords the customer an additional measure of flexibility in the use of their access circuits. The arrangement can be utilized to transfer a leg of a Special Access Service to another circuit that terminates in either the same or a different customer premises. A key activated or dial-up control service is required to operate the transfer arrangement. A spare circuit, if required, is not included as part of the option.

(11) Four-Wire/Two-Wire Conversions

The term "Effective 2-Wire" denotes a condition which permits the simultaneous transmission in both directions over a channel, but it is not possible to insure independent information transmission in both directions. Effective 2-wire channels may be terminated with 2-wire or 4-wire interfaces.

The term "Effective 4-Wire" denotes a condition which permits the simultaneous independent transmission of information in both directions over a channel. The method of implementing effective 4-wire transmission is at the discretion of the Telephone Company (physical, time domain, frequency-domain separation or echo cancellation techniques). Effective 4-wire channels may be terminated with a 2-wire interface at the customer's premises. However, when terminated 2-wire, simultaneous independent transmission cannot be supported because the two wire interface combines the transmission paths into a single path.

When a customer requests that an effective four-wire circuit be terminated with a two-wire circuit interface at the customer designated premises, a four-wire to two-wire conversion is required. The customer will be charged the 4-wire Circuit Termination rate when an effective four-wire is specified in the customer's order. The rate for the conversion is included as part of the basic Circuit Termination rate.

ACCESS SERVICE

7. Special Access Service (Cont'd)

7.5 Voice Grade Service (Cont'd)

7.5.4 Optional Features and Functions (Cont'd)

The following table shows the technical specifications packages with which the optional features and functions are available.

	C*	Available with Technical Specifications Package VG-												SI
		1	2	3	4	5	6	7	8	9	10	11	12	
C-Type Conditioning Central Office	X						X	X	X	X	X	X		
Bridging Capability Central Office	X		X			X	X				X	X	X	
Multiplexing	X						X							
Customer Specified Premises Receive Level	X		X	X				X	X	X				
Data Capability	X						X	X			X			
Improved Return Loss -For Effective Four-Wire Transmission	X	X	X	X	X	X	X	X	X	X	X	X	X	X
-For Effective Two-Wire Transmission	X		X	X				X						X
Sealing Current Conditioning	X						X							
Selective Signaling Arrangement	X		X			X	X				X	X	X	
Signaling Capability	X	X	X	X				X	X	X				#
Transfer Arrangement	X	X	X	X	X	X	X	X	X	X	X	X	X	

Signaling is provided in conjunction with Switched Access as set forth in 6.3.2(T) preceding.

ACCESS SERVICE

7. Special Access Service (Cont'd)

7.5 Voice Grade Service (Cont'd)

7.5.5 Rates and Charges

(A) Circuit Termination

- Per Point of Termination, Competitive Counties

<u>Jurisdiction</u>	<u>2-Wire Monthly Rates</u>	<u>2-Wire Nonrecurring Charges</u>
California	\$3,286.03	\$27,383.93
Texas	\$3,820.23	\$27,383.93

<u>Jurisdiction</u>	<u>4-Wire Monthly Rates</u>	<u>4-Wire Nonrecurring Charges</u>
California	\$4,771.69	\$27,383.93
Texas	\$4,956.51	\$27,383.93

(B) Circuit Mileage

<u>Jurisdiction</u>	<u>Monthly Rates - Fixed</u>	<u>Monthly Rates - Per Mile</u>
California	\$2,374.37	\$150.80
Texas	\$1,331.00	\$239.68

Disconnect Non-Recurring Charge
2Wire/4Wire/VG per Circuit per Jurisdiction \$975.00

(C)

(C)

ACCESS SERVICE

7. Special Access Service (Cont'd)

7.5 Voice Grade Service (Cont'd)

7.5.5 Rates and Charges (Cont'd)

(C) Optional Features and Functions

Rates and charges for the Optional Features and Functions of Voice Grade Service listed in this section apply to all jurisdictions of the Issuing Carriers listed on the Title Pages.

	<u>Monthly Rates</u>	<u>Nonrecurring Charge</u>
(1) Bridging		
(a) Voice Bridging		
- Per port		
- Two-Wire	\$8.00	None
- Four-Wire	8.00	None
(b) Data Bridging		
- Per Port		
- Two-Wire	8.00	None
- Four-Wire	8.00	None
(c) Telephoto Bridging		
- Per port		
- Two-Wire	8.00	None
- Four-Wire	8.00	None

ACCESS SERVICE

7. Special Access Service (Cont'd)

7.5 Voice Grade Service (Cont'd)

7.5.5 Rates and Charges (Cont'd)

(C) Optional Features and Functions (Cont'd)

	<u>Monthly Rates</u>	<u>Nonrecurring Charge</u>
(1) Bridging (Cont'd)		
(d) DATAPHONE Select-A-Station Bridging		
Sequential Arrangement Ports		
- Per Circuit Connected		
- 2-Wire	21.23	None
- 4-Wire	112.80	None
Addressable Arrangement Ports		
- Per Circuit Connected		
- 2-Wire	22.76	None
- 4-Wire	115.88	None
(e) Telemetry and Alarm Bridging		
Active Bridging Circuit Connections		
- Per Circuit Connected		
- Split Band	\$8.04	None
- Summation	1.37	None
Passive Bridging Circuit Connections		
- Per Circuit Connected		
	0.20	None

ACCESS SERVICE

7. Special Access Service (Cont'd)

7.5 Voice Grade Service (Cont'd)

7.5.5 Rates and Charges (Cont'd)

(C) Optional Features and Functions (Cont'd)

	<u>Monthly Rates</u>	<u>Nonrecurring Charge</u>
(2) Conditioning		
- Per Point of Termination C - Type	11.12	None
Improved C-Type Conditioning Options		
- Improved Attenuation Distortion	*	None
- Improved Envelope Delay Distortion	*	None
Sealing Current	None	None
(3) Improved Return Loss for Effective Four-Wire Transmission		
- Per Point of Termination		
- Two-Wire	3.75	None
- Four-Wire	3.75	None
(4) Customer Specified Receive Level		
- Per Two-Wire Point of Termination	None	None
(5) Reserved for Future Use		
(6) Data Capability		
- Per Point of Termination	2.00	0.00
(7) Telephoto Capability		
- Per Point of Termination	2.81	0.00

* Applied at the same rate as C-Type Conditioning regardless if one or both Improved C-Type options are ordered.

ACCESS SERVICE

7. Special Access Service (Cont'd)

7.5 Voice Grade Service (Cont'd)

7.5.5 Rates and Charges (Cont'd)

(C) Optional Features and Functions (Cont'd)

	<u>Monthly Rates</u>	<u>Nonrecurring Charge</u>
(8) Signaling Capability - Per Point of Termination	16.51	None
(9) Selective Signaling Arrangement - Per Arrangement	\$32.11	None
(10) Transfer Arrangement (Key Activated* or Dial Up**) - Per Four Port Arrangement, including control circuit termination***	3.00	None
- Per Five Port Arrangement, including control circuit termination***	6.85	None

* The key activated control circuit is also rated as a Voice Grade Service.

** The Dial-up option requires the customer to purchase the Controller Arrangement (USOC XTDDU) from 13.3.8 following.

*** An additional Circuit Termination charge will apply whenever a spare circuit is configured as a leg to the customer's premises. Additional circuit mileage charges will apply when the transfer arrangement is not located in the customer premises serving wire center.

ACCESS SERVICE

7. Special Access Service (Cont'd)

7.6 Program Audio Service #

7.6.1 Basic Circuit Description

A Program Audio circuit is a circuit measured in Hz for the transmission of a complex signal voltage. The actual bandwidth is a function of the channel interface selected by the customer. The nominal frequency bandwidths are from 50 to 15000 Hz, from 200 to 3500 Hz, from 100 to 5000 Hz or from 50 to 8000 Hz. Only one-way transmission is provided. Program Audio circuits are provided between customer designated premises or between a customer designated premises and a Telephone Company hub.

7.6.2 Technical Specifications Packages

Parameter	<u>Package AP-</u>				
	<u>C*</u>	<u>1</u>	<u>2</u>	<u>3</u>	<u>4</u>
Actual Measured Loss	X	X	X	X	X
Amplitude Tracking	X				
Crosstalk	X	X	X	X	X
Distortion Tracking	X				
Gain/Frequency					
Distortion	X	X	X	X	X
Group Delay	X				
Noise	X	X	X	X	X
Phase Tracking	X				
Short-Term Gain Stability	X				
Short-Term Loss	X				
Total Distortion	X	X	X	X	X

The technical specifications are delineated in Technical Reference GR-337-CORE, Issue 1.

* The desired parameters are selected by the customer from the list available parameters.

Effective January 22, 2014, orders for new Program Audio Service are no longer permitted. The Telephone Company will continue to provide Program Audio Service pursuant to this Section 7.6 on existing Program Audio Service in service as of January 22, 2014, or orders for Program Audio Service placed with the Telephone Company prior to January 22, 2014 (collectively, Existing Program Audio Service), subject to the following condition:

The Telephone Company will continue to provide Existing Program Audio Service until the earlier of the date that customer replaces the Existing Program Audio Service with a comparable Telephone Company-provided service, or the date that customer discontinues service, or the date that Telephone Company discontinues service. Moves, additions, and changes are not permitted.

ACCESS SERVICE

7. Special Access Service (Cont'd)

7.6 Program Audio Service # (Cont'd)

7.6.3 Channel Interfaces

The following channel interfaces (CIs) define the bandwidths that are available for a Program Audio circuit:

<u>CI</u>	<u>Bandwidth</u>
PG-1	Nominal frequency from 50 to 15000 Hz
PG-3	Nominal frequency from 200 to 3500 Hz
PG-5	Nominal frequency from 100 to 5000 Hz
PG-8	Nominal frequency from 50 to 8000 Hz

Compatible channel interfaces are set forth in 9 following.

7.6.4 Optional Features and Functions

(1) Central Office Bridging Capability

Distribution Amplifier

(2) Gain Conditioning

Control of 1004 Hz AML at initiation of service to OdB + 0.5 dB.

(3) Stereo

Provision of a pair of gain/phase equalized channels for stereo applications. (Additional AP channel must be ordered separately).

The following table shows the technical specifications packages with which the optional features and functions are available.

	Available with Technical Specifications Package AP-				
	<u>C</u>	<u>1</u>	<u>2</u>	<u>3</u>	<u>4</u>
Central Office Bridging Capability	X	X	X	X	X
Gain Conditioning	X	X	X	X	X
Stereo	X	X			

Service availability limited. Refer to # footnote on Page 7-61.

ACCESS SERVICE

7. Special Access Service (Cont'd)

7.6 Program Audio Service # (Cont'd)

7.6.5 Rates and Charges

(A) Circuit Termination
- Per Point of Termination, Competitive Counties

<u>200-3500 Hz</u>			
<u>Jurisdiction</u>	<u>Monthly Rates</u>	<u>Daily Rates</u>	<u>Nonrecurring Charges</u>
California	\$37.94	\$3.79	\$200.00
Texas	53.52	5.35	200.00

<u>100-5000 Hz</u>			
<u>Jurisdiction</u>	<u>Monthly Rates</u>	<u>Daily Rates</u>	<u>Nonrecurring Charges</u>
California	\$37.94	\$3.79	\$200.00
Texas	53.52	5.35	200.00

<u>50-8000 Hz</u>			
<u>Jurisdiction</u>	<u>Monthly Rates</u>	<u>Daily Rates</u>	<u>Nonrecurring Charges</u>
California	\$37.94	\$3.79	\$200.00
Texas	53.52	5.35	200.00

<u>50-15000 Hz</u>			
<u>Jurisdiction</u>	<u>Monthly Rates</u>	<u>Daily Rates</u>	<u>Nonrecurring Charges</u>
California	\$37.94	\$3.79	\$200.00
Texas	53.52	5.35	200.00

Service availability limited. Refer to # footnote on Page 7-61.

ACCESS SERVICE

7. Special Access Service (Cont'd)

7.6 Program Audio Service # (Cont'd)

7.6.5 Rates and Charges (Cont'd)

(B) Circuit Mileage

<u>200-3500 Hz</u>		
	<u>Monthly Rate</u>	<u>Monthly Rate</u>
<u>Jurisdiction</u>	<u>Fixed</u>	<u>Per Mile</u>
California	\$55.20	\$4.64
Texas	25.80	2.81

<u>200-3500 Hz</u>		
	<u>Daily Rate</u>	<u>Daily Rate</u>
<u>Jurisdiction</u>	<u>Fixed</u>	<u>Per Mile</u>
California	\$5.52	\$.47
Texas	2.58	.28

<u>100-5000 Hz</u>		
	<u>Monthly Rate</u>	<u>Monthly Rate</u>
<u>Jurisdiction</u>	<u>Fixed</u>	<u>Per Mile</u>
California	\$55.20	\$4.64
Texas	25.80	2.81

<u>100-5000 Hz</u>		
	<u>Daily Rate</u>	<u>Daily Rate</u>
<u>Jurisdiction</u>	<u>Fixed</u>	<u>Per Mile</u>
California	\$5.52	\$.47
Texas	2.58	.28

Service availability limited. Refer to # footnote on Page 7-61.

ACCESS SERVICE

7. Special Access Service (Cont'd)

7.6 Program Audio Service # (Cont'd)

7.6.5 Rates and Charges (Cont'd)

(B) Circuit Mileage (Cont'd)

<u>50-8000 Hz</u>		
	<u>Monthly Rate</u>	<u>Monthly Rate</u>
<u>Jurisdiction</u>	<u>Fixed</u>	<u>Per Mile</u>
California	\$55.20	\$4.64
Texas	25.80	2.81

<u>50-8000 Hz</u>		
	<u>Daily Rate</u>	<u>Daily Rate</u>
<u>Jurisdiction</u>	<u>Fixed</u>	<u>Per Mile</u>
California	\$5.52	\$.47
Texas	2.58	.28

<u>50-15000 Hz</u>		
	<u>Monthly Rate</u>	<u>Monthly Rate</u>
<u>Jurisdiction</u>	<u>Fixed</u>	<u>Per Mile</u>
California	\$55.20	\$4.64
Texas	25.80	2.81

<u>50-15000 Hz</u>		
	<u>Daily Rate</u>	<u>Daily Rate</u>
<u>Jurisdiction</u>	<u>Fixed</u>	<u>Per Mile</u>
California	\$5.52	\$.47
Texas	2.58	.28

Service availability limited. Refer to # footnote on Page 7-61.

ACCESS SERVICE

7. Special Access Service (Cont'd)

7.6 Program Audio Service # (Cont'd)

7.6.5 Rates and Charges (Cont'd)

(C) Optional Features and Functions

Rates and charges for the Optional Features and Functions of Program Audio Service listed in this section apply to all jurisdictions of the Issuing Carriers listed on the Title Pages.

	<u>Monthly Rates</u>	<u>Daily Rates</u>	<u>Nonrecurring Charges Monthly</u>	<u>Nonrecurring Charges Daily</u>
(1) Bridging, Distribution Amplifier - Per Port	\$1.00	\$.10	None	None
(2) Gain Conditioning - Per Service	1.00	.10	None	None
(3) Stereo - Per service	None	None	None	None

Service availability limited. Refer to # footnote on Page 7-61.

ACCESS SERVICE

7. Special Access Service (Cont'd)

7.7 TV-1 Analog Service

7.7.1 Basic Circuit Description

A TV-1 Analog circuit is a circuit with one-way transmission capability for a standard 525 line/60 field monochrome, or National Television Systems Committee color video signal and one or two associated 5 or 15 kHz audio signal(s). The bandwidth for a video circuit is either 30 Hz to 4.5 MHz or 30 Hz to 6.6 MHz. The associated audio signal(s) may be either duplexed or provided as one or two separate circuits. The provision and the bandwidth of the associated audio signal(s) is a function of the channel interface selected by the customer. TV-1 Analog circuits are provided between customer designated premises or between a customer designated premises and a Telephone Company hub.

7.7.2 Technical Specifications Packages

<u>Parameter</u>	<u>Package TV-</u>		
	<u>C*</u>	<u>1</u>	<u>2</u>
Amplitude vs. Frequency Response	X		
Chrominance/Luminance Inequalities			
Gain	X	X	X
Delay	X	X	X
Chrominance/Luminance Intermodulation	X		
Chrominance Nonlinear Gain	X		
Chrominance Nonlinear Phase	X		
Crosstalk	X		X
Differential Gain	X	X	X
Differential Phase	X	X	X
Dynamic Gain (picture and sync signal)	X		
Field-Time Distortion	X	X	X
Gain/Frequency Distortion	X	X	X
Gain Stability	X	X	X
Insertion Gain	X	X	X
Line-Time Distortion	X	X	X
Long-Time Distortion	X	X	X

* The desired parameters are selected by the customer from the list of available parameters.

ACCESS SERVICE

7. Special Access Service (Cont'd)

7.7 TV-1 Analog Service (Cont'd)

7.7.2 Technical Specifications Packages (Cont'd)

<u>Parameter</u>	<u>Package TV-</u>		
	<u>C*</u>	<u>1</u>	<u>2</u>
Luminance Nonlinearity	X		
Luminance Signal/CCIR			
Weighted Noise	X	X	X
Short-Time Distortion			
2 T Pulse	X	X	X
T - Bar Ringing	X	X	X
Signal/15 kHz Flat			
Weighted Noise	X	X	X
Signal/Low Frequency Noise	X		
Stereo Gain Difference	X	X	
Stereo Phase Difference	X	X	
Total Harmonic Distortion	X	X	X
Transient Sync Signal			
Non-Linearity	X		
Video/Audio Delay Difference	X		

The technical specifications are delineated in Technical Reference GR-338-CORE, Issue 1, and associated Addendum.

* The desired parameters are selected by the customer from the list of available parameters.

ACCESS SERVICE

7. Special Access Service (Cont'd)

7.7 TV-1 Analog Service (Cont'd)

7.7.3 Channel Interfaces

The following channel interfaces (CIs) define the bandwidth and the provision of the audio signal(s) associated with a TV-1 Analog circuit:

<u>CI</u>	<u>Audio Bandwidth</u>	<u>Provision Audio Channels</u>
02TV7.15	15kHz	1 or 2 Channels, separate
04TV6.15	15kHz	1 or 2 Channels, separate
04TV6.15A	15kHz	1, 2, 3, or 4 Channels, separate
04TV6.20A	20kHz	1, 2, 3, or 4 Channels, separate
04TV7.15	15kHz	1 or 2 Channels, separate
04TV7.15A	15kHz	1, 2, 3 or 4 Channels, separate
04TV7.20A	20kHz	1, 2, 3, or 4 Channels, separate
06TV6.15	15kHz	1 or 2 Channels, separate
06TV6.15A	15kHz	1, 2, 3 or 4 Channels, separate
06TV6.20A	20kHz	1, 2, 3, or 4 Channels, separate
06TV7.15	5kHz	1 or 2 Channels, separate
08TV6.15A	15kHz	1, 2, 3 or 4 Channels, separate
10TV6.15A	15kHz	1, 2, 3 or 4 Channels, separate
10TV6.20A	20kHz	1, 2, 3, or 4 Channels, separate

Compatible channel interfaces are set forth in 9. following.

ACCESS SERVICE

7. Special Access Service (Cont'd)

7.7 TV-1 Analog Service (Cont'd)

7.7.4 Rate Application

(A) General

TV1-Analog service is available under a month-to-month arrangement or on a term commitment plan of 1, 2, 3 or 5 years. The month-to-month offering requires a minimum service period of three months.

Where appropriate facilities are not available, Special Construction charges may apply as set forth in Section 5.1.12 preceding to provide such facilities required to meet the customer's request.

(1) TV1-Analog Dedicated Video Line

The TV1-Analog Dedicated Video Line (DVL) rate element provides for a non-switched TV1-Analog line connection between the customer dedicated location and its serving wire center for the purpose of point-to-point video transmission without connecting to a Telephone Company video switch.

(2) TV1-Analog Transport

The TV1-Analog Transport rate element provides for the interoffice transmission facilities for service arrangements where the customer designated locations are not served by the same wire center. Where a service is provided by more than one company, transport will be measured to the meet point as set forth under Section 5.2. Transport rates are applied per airline mile.

(3) TV1-Analog Optional Features

One or two audio channels are provided with each TV1-Analog arrangement. Auxiliary audio channels 4TV5, 6TV5 and TV15 are provided as part of TV1-Analog service at no additional charge.

ACCESS SERVICE

7. Special Access Service (Cont'd)

7.7 TV-1 Analog Service (Cont'd)

7.7.4 Rate Application (Cont'd)

(B) Term Commitment Plan (TCP)#

(T)

(1) General

TV1-Analog service is available on a Term Commitment Plan (TCP) of 1, 2, 3 or 5 year plan rates as set forth under 7.7.5 following.

- (a) The customer must designate on the ASR the commitment term selected.
- (b) Inside moves in accordance with 7.2.1(D)(4)(A) will not incur termination liability charges.
- (c) Outside moves in accordance with 7.2.1(D)(4)(B) will allow the customer to retain the same TCP period. Any other move will be treated as a disconnect of the service and termination liability charges will apply.

(2) Change in Term Length

Prior to the completion of the selected TCP term, the customer may elect to convert to a new TCP of the same or different term length subject to the following:

- (a) No term credit is applied for payments made under the original plan.
- (b) If the new term selected is shorter than the time remaining under the existing TCP, the change to the new TCP constitutes a disconnect of the existing TCP and termination liability charges will apply.

Effective November 21, 2017, new subscriptions to Term Commitment Plan are no longer permitted. TCP customers subscribed as of November 16, 2017 may continue with their existing subscriptions. If at any time an existing customer terminates its TCP, the customer may not re-subscribe to the plan.

ACCESS SERVICE

7. Special Access Service (Cont'd)

7.7 TV-1 Analog Service (Cont'd)

7.7.4 Rate Application (Cont'd)

(B) Term Commitment Plan (TCP)# (Cont'd)

(3) Renewal Options

- (a) At the expiration of a TCP period, the Telephone Company will automatically renew the service at the same TCP period unless the customer chooses to convert to month-to-month, to convert to a different TCP, or to discontinue service.
- (b) Conversion to a different TCP period will require the customer to submit a change order ASR. Conversion to a different TCP period will be allowed without application of any nonrecurring or ordering charges.
- (c) Conversion to month-to-month rates will be treated as a disconnect of service and establishment of new service. If no other changes are ordered, no NRCs will apply.

(4) Notification of Discontinuance

An ASR for discontinuance of a TCP arrangement must be received by the Telephone Company at least thirty (30) business days prior to actual disconnect of service. Monthly rates will apply for a period of thirty (30) business days from the date the Telephone Company receives disconnect notification or until the requested disconnect date, if longer than thirty (30) business days. (C)

Service Availability is limited. Refer to # footnote on page 7-71.

ACCESS SERVICE

7. Special Access Service (Cont'd)

7.7 TV-1 Analog Service (Cont'd)

7.7.4 Rate Application (Cont'd)

(B) Term Commitment Plan (TCP)# (Cont'd)

(5) Termination Liability

When a TCP is discontinued prior to the end of the commitment period, termination liability charges, as set forth following, will apply based on the remainder of the TCP period in effect at the time of disconnect.

- (a) One-Year TCP - 50% of any remaining portion of the first year's monthly rates.
- (b) Two-Year TCP - 50% of any remaining portion of the first year's monthly rates. In addition, for any remaining portion of the second year, the customer will be liable for 10% of the total monthly rates in that time period.
- (c) Three-Year TCP - 50% of any remaining portion of the first year's monthly rates. In addition, for any remaining portion of the second and third years, the customer will be liable for 10% of the total monthly rates in that time period.
- (d) Five-Year TCP - 50% of any remaining portion of the first year's monthly rates. In addition, for any remaining portion of the second through fifth years, the customer will be liable for 20% of the total monthly rates in that time period.

(6) Reserved for Future Use (C)

Service Availability is limited. Refer to # footnote on page 7-71.

ACCESS SERVICE

7. Special Access Service (Cont'd)

7.7 TV-1 Analog Service (Cont'd)

7.7.5 Rates and Charges

(A) TV-1 Analog Dedicated Video Line
- Per Point of Termination

<u>Jurisdiction</u>	<u>Month-to-Month</u>		<u>One Year</u>	
	<u>Nonrecurring Charge</u>	<u>Monthly Rate</u>	<u>Nonrecurring Charge</u>	<u>Monthly Rate</u>
California--Competitive	\$1,000.00	\$535.00	\$500.00	\$511.00
Texas--Competitive	1,000.00	535.00	500.00	511.00

<u>Jurisdiction</u>	<u>Two Year</u>		<u>Three Year</u>	
	<u>Nonrecurring Charge</u>	<u>Monthly Rate</u>	<u>Nonrecurring Charge</u>	<u>Monthly Rate</u>
California--Competitive	\$0.00	\$500.00	\$0.00	\$495.00
Texas--Competitive	0.00	500.00	0.00	495.00

<u>Jurisdiction</u>	<u>Five Year</u>	
	<u>Nonrecurring Charge</u>	<u>Monthly Rate</u>
California--Competitive	\$0.00	\$490.00
Texas--Competitive	0.00	490.00

Service Availability is limited. Refer to # footnote on page 7-71.

ACCESS SERVICE

7. Special Access Service (Cont'd)

7.7 TV-1 Analog Service (Cont'd)

7.7.5 Rates and Charges (Cont'd)

(B) TV-1 Analog Transport

- per airline mile

<u>Jurisdiction</u>	<u>Month-to-Month Nonrecurring Charge</u>	<u>One Year Monthly Rate</u>	<u>Nonrecurring Charge</u>	<u>Monthly Rate</u>
California	N/A	\$150.00	N/A	\$145.00
Texas	N/A	150.00	N/A	145.00

<u>Jurisdiction</u>	<u>Two Year Nonrecurring Charge</u>	<u>Three Year Monthly Rate</u>	<u>Nonrecurring Charge</u>	<u>Monthly Rate</u>
California	N/A	\$140.00	N/A	\$135.00
Texas	N/A	140.00	N/A	135.00

<u>Jurisdiction</u>	<u>Five Year Nonrecurring Charge</u>	<u>Monthly Rate</u>
California	N/A	\$130.00
Texas	N/A	130.00

7.8 Reserved for Future Use

7.9 Reserved for Future Use

Service Availability is limited. Refer to # footnote on page 7-71.

ACCESS SERVICE

7. Special Access Service (Cont'd)

7.10 Digital Data Service

7.10.1 Basic Circuit Description

A Digital Data circuit is a circuit for duplex four-wire transmission of synchronous serial data at the rate of 2.4, 4.8, 9.6, 19.2, 56, or 64 Kbps. The actual bit rate is a function of the channel interface selected by the customer. The circuit provides a synchronous service with timing provided by the Telephone Company through the Telephone Company's facilities to the customer in the received bit stream. Digital Data circuits are only available via Telephone Company designated hubs and are provided between customer designated premises or between a customer designated premises and a Telephone Company hub.

The customer may provide the Channel Service Unit-type equipment or other Network Channel Terminating Equipment associated with the Digital Data circuit at the customer premises. The interim program for interconnection of such equipment is set forth in Technical Reference PUB AS No. 1, Issue II.

7.10.2 Technical Specifications Packages

<u>Parameter</u>	<u>Package DA</u>			
	<u>1</u>	<u>2</u>	<u>3</u>	<u>4</u>
Error-Free Seconds	X	X	X	X

The Telephone Company will provide a circuit capable of meeting a monthly average performance equal to or greater than 99.875% error-free seconds while the circuit is in service, if it is measured through a CSU equivalent which is designed, manufactured, and maintained to conform with the specifications contained in Technical Reference PUB 62310.

Voltages which are compatible with Digital Data Service are delineated in Technical Reference TR-NWT-000341, Issue 2.

ACCESS SERVICE

7. Special Access Service (Cont'd)

7.10 Digital Data Service (Cont'd)

7.10.3 Channel Interfaces

The following channel interfaces (CIs) define the bit rates that are available for a Digital Data circuit.

<u>CI</u>	<u>Bit Rate</u>
DU-24	2.4 Kbps
DU-48	4.8 Kbps
DU-96	9.6 Kbps
DU-19	19.2 Kbps
DU-565	56 Kbps
DU-64	64 Kbps

Compatible channel interfaces are set forth in 9. following.

7.10.4 Optional Features and Functions

- (1) Central Office Bridging Capability
- (2) Transfer Arrangement

An arrangement that affords the customer an additional measure of protection and/or flexibility in the use of their access circuit(s) on a 1xN basis. The arrangement can be utilized to transfer a leg of a Special Access Service to either a spare or working circuit that terminates in either the same or a different customer designated premises. This arrangement is only available at a Telephone Company designated hub. A key activated or dial-up control service is required to operate the transfer arrangement. A spare circuit, if required, is not included as a part of the option.

ACCESS SERVICE

7. Special Access Service (Cont'd)

7.10 Digital Data Service (Cont'd)

7.10.5 Rates and Charges

(A) Circuit Termination

- Per Point of Termination, Competitive Counties

<u>Jurisdiction</u>	<u>2.4, 4.8, 9.6, 19.2 Kbps</u>		(C)
	<u>Monthly Rate</u>	<u>Nonrecurring Charge</u>	
California	\$9,207.66	\$34,230.00	
Texas	\$11,273.89	\$34,230.00	

<u>Jurisdiction</u>	<u>56 & 64 Kbps</u>		(C)
	<u>Monthly Rate</u>	<u>Nonrecurring Charge</u>	
California	\$12,072.41	\$34,230.00	
Texas	\$14,056.09	\$34,230.00	

(B) Circuit Mileage

<u>Jurisdiction</u>	<u>All Speeds</u>		(C)
	<u>Monthly Rate Fixed</u>	<u>Monthly Rate Per Mile</u>	
California	\$2,330.32	\$432.55	
Texas	\$3,685.94	\$623.16	

<u>Disconnect Non-Recurring Charge</u>		
per Circuit	All Jurisdictions All Speeds	\$975.00

ACCESS SERVICE

7. Special Access Service (Cont'd)

7.10 Digital Data Service (Cont'd)

7.10.5 Rates and Charges

(C) Optional Features and Functions

Monthly Rates and Nonrecurring Charges for the Optional Features and Functions of Digital Data Service listed in this section apply to all jurisdictions of the Issuing Carriers listed on the Title Pages.

Optional Features and Functions	Monthly Rates	Nonrecurring Charges
(1) Bridging - Per Port	\$11.00	None
(2) Loop Transfer Arrangement (Key Activated* or Dial-Up**) - Per Four-Port Arrangement***	5.96	None

* The key activated control is rated as a Voice Grade Circuit Termination (use USOC TME2X) and Circuit Mileage, if applicable (use USOCs TRG and 1LFSX).

** The Dial-Up option requires the customer to purchase the Controller Arrangement (USOC XTDDU) from 8.7(A) following.

*** An additional Circuit Termination charge will apply whenever a spare circuit is configured as a leg to the customer's premises. Additional Circuit Mileage charges will also apply when the transfer arrangement is not located in the customer premises serving wire center.

ACCESS SERVICE

7. Special Access Service (Cont'd)

7.11 High Capacity Service**

7.11.1 Basic Circuit Description

A High Capacity circuit is a circuit for the transmission of nominal 64.0 kbps* or 1.544, 3.152, 6.312, 44.736, or 274.176 Mbps isochronous serial data. The actual bit rate is a function of the channel interface selected by the customer. High Capacity circuits are provided between customer designated premises or between a customer designated premises and a Telephone Company hub. High Capacity DS1 and DS3 services may also be connected to customer transmission equipment and facilities where the customer is provided EIS as defined in Section 17. High Capacity circuits may also be connected to an in-service Telephone Company provided integrated optical service, provided that such connections are technically and operationally feasible, as determined by the Telephone Company.

The customer may provide the Network Channel Terminating Equipment associated with the High Capacity circuit at the customer's premises. The interim program for interconnection of such equipment is set forth in Technical Reference PUB AS No. 1, Issue II.

7.11.2 Technical Specifications Packages

<u>Parameter</u>	<u>Package HC</u>					
	<u>0</u>	<u>1</u>	<u>1C</u>	<u>2</u>	<u>3</u>	<u>4</u>
Error-Free Seconds		X				

A circuit with technical specifications package HC1 will be capable of an error-free second performance of 98.75% over a continuous 24 hour period as measured at the 1.544 Mbps rate through a CSU equivalent which is designed, manufactured, and maintained to conform with the specifications contained in Technical Reference GR-54-CORE, Issue 1.

* Available only as a circuit of a 1.544 Mbps facility to a Telephone Company Digital Data hub or as a cross connect of two 2.4, 4.8, 9.6, 56.0 or 64.0 kbps circuits of two 1.544 Mbps facilities to a Digital Data hub(s). The customer must provide system and channel assignment data.

** DS1 and DS3 Special Access Service may be provided between service areas shown under 7.1.10, where facilities and conditions permit.

ACCESS SERVICE

7. Special Access Service (Cont'd)

7.11 High Capacity Service (Cont'd)

7.11.3 Channel Interfaces

The following channel interfaces (CIs) define the bit rates that are available for a High Capacity circuit:

<u>CI</u>	<u>Bit Rate</u>
DS-15*	1.544 Mbps (DS1)
DS-27	274.176 Mbps (DS4)
DS-31	3.152 Mbps (DSIC)
DS-44	44.736 Mbps (DS3)
DS-63	6.312 Mbps (DS2)

Compatible channel interfaces are set forth in 9.3.5 following.

7.11.4 Optional Features and Functions

(1) Automatic Loop Transfer

The Automatic Loop Transfer provides protection on a 1xN basis against failure of the facilities between a customer designated premises and the wire center serving that premises. Protection is furnished through the use of a switching arrangement that automatically switches to a spare circuit line when a working line fails. The spare circuit is not included as a part of the option. This option requires compatible equipment at both the serving wire center and the customer premises. The customer is responsible for providing the equipment at its premises. Equipment at the customer premises will be provided under tariff only if it existed in the Telephone Company inventory as of November 18, 1983.

(2) Transfer Arrangement

An arrangement that affords the customer an additional measure of flexibility in the use of their access circuit(s). The arrangement can be utilized to transfer a leg of a Special Access Service to either a spare or working circuit that terminates in either the same or a different customer designated premises. A key activated or dial-up control service is required to operate the transfer arrangement. A spare circuit, if required, is not included as part of the option.

* A 64.0 kbps circuit is available as a circuit(s) of a 1.544 Mbps facility to a Telephone Company hub.

ACCESS SERVICE

7. Special Access Service (Cont'd)

7.11 High Capacity Service (Cont'd)

7.11.4 Optional Features and Functions (Cont'd)

(3) Central Office Multiplexing

(a) DS4 to DS1

An arrangement that converts a 274.176 Mbps circuit to 168 DS1 circuits using digital time division multiplexing.

(b) DS3 to DS1

An arrangement that converts a 44.736 Mbps circuit to 28 DS1 circuits using digital time division multiplexing.

(c) DS2 to DS1

An arrangement that converts a 6.312 Mbps circuit to four DS1 circuits using digital time division multiplexing.

(d) Reserved for Future Use

(e) DS1 to Voice

An arrangement that converts a 1.544 Mbps circuit to 24 circuits for use with Voice Grade Services.

If this DS1 terminates in a DDS hub, a channel(s) of the DS1 can be used to provide DDS; however, DDS service stops at the DS1 interface.

Up to 16 channels of this DS1 can be used for Direct Digital Service (DDS-like service) with the assurance that circuit performance parameters will be met. If more than 16 channels are used for DDS-like service, the performance parameters for the DS1 and all circuits riding the DS1 will not be guaranteed.

(f) DS1 to DS0

An arrangement that converts a 1.544 Mbps circuit to twenty three (23) 64.0 Kbps circuits utilizing digital time division multiplexing.

ACCESS SERVICE

7. Special Access Service (Cont'd)

7.11 High Capacity Service (Cont'd)

7.11.4 Optional Features and Functions (Cont'd)

(3) Central Office Multiplexing (Cont'd)

(g) DS0 to Subrate

An arrangement that converts a 64.0 kbps circuit to subspeeds of up to twenty 2.4 kbps, ten 4.8 kbps, or five 9.6 kbps circuits using digital time division multiplexing.

(4) Clear Channel Capability (CCC)

CCC provides a Bipolar with Eight Zero Substitution (B8ZS) encoding technique that allows a customer to transport 1.536 Mbps information rate signals over a 1.544 Mbps High Capacity Channel with no restraint on the quantity or sequence of one (mark) and zero (space) bits. This arrangement allows customers to derive 64 kbps clear channels. This service is provided only on 1.544 Mbps High Capacity Channels between two customer designated premises and is subject to availability of facilities. This arrangement requires the customer-provided multiplexing equipment to be compatible with the B8ZS line code as specified in Technical Reference GR-54-CORE, Issue 1, and Technical Reference GR-342-CORE, Issue 1.

(5) DS3 Premises Multiplexer

(a) At the option of the customer, a DS3 High Capacity Service may be ordered with a DS3 to DS1 multiplexer located at a customer designated premises (DS3 Premises Multiplexer). The DS3 Premises Multiplexer will be provided by the Telephone Company and will be located within the Telephone Company's communications facilities (i.e., within the Telephone Company's network) and on the Telephone Company's side of the Point of Termination as defined in Section 2.6 preceding. The DS3 Premises Multiplexer allows up to twenty-eight (28) DS1 circuits to be derived from the DS3 High Capacity facility. The DS1 circuits derived from the DS3 Premises Multiplexer must terminate at that premises and will extend beyond the DS3 Premises Multiplexer to a Point of Termination (as defined in Section 2.6 preceding). The DS3 Premises Multiplexer is not available with DS3 High Capacity Service provided with an optical interface. The Telephone Company will commence billing for the DS3 High Capacity Service and DS3 Premises Multiplexer on the Service Date for the multiplexed DS3 facility. Individual DS1 circuits derived from the multiplexed DS3 High Capacity facility may only be ordered and installed subsequent to the installation of the facility to the DS3 Premises Multiplexer.

ACCESS SERVICE

7. Special Access Service (Cont'd)

7.11 High Capacity Service (Cont'd)

7.11.4 Optional Features and Functions (Cont'd)

(5) DS3 Premises Multiplexer (Cont'd)

- (b) When a DS3 High Capacity Service is multiplexed at a customer designed premises, such configuration is not a Telephone Company Hub for purposes of administering the terms and conditions of this Guide.
- (c) The DS3 Premises Multiplexer optional feature may not be used on a DS3 High Capacity Service that is derived from a higher capacity service at the same customer designated premises (e.g., a DS3 High Capacity Service that is derived at that premises from an OC12 level service or node).
- (d) The rates and charges for the DS3 Premises Multiplexer optional feature as set forth in Section 7.11.5(L)(1) following apply in addition to the applicable DS3 circuit termination rates and charges at that same customer designated premises. DS1 circuit termination rates and charges do not apply at the customer designated premises where such DS1 channels are derived from a DS3 Premises Multiplexer.
- (e) The DS3 Premises Multiplexer optional feature cannot be located at an Expanded Interconnection Service arrangement as set forth in Section 17 following.

ACCESS SERVICE

7. Special Access Service (Cont'd)

7.11 High Capacity Service (Cont'd)

7.11.4 Optional Features and Functions (Cont'd)

(6) The following table shows the technical specifications packages with which the optional features and functions are available.

<u>Parameter</u>	Available with Technical Specifications Package HC-					
	<u>0</u>	<u>1</u>	<u>1C</u>	<u>2</u>	<u>3</u>	<u>4</u>
Automatic Loop Transfer Central Office		X				
Multiplexing:						
DS4 to DS1						X
DS3 to DS1					X	
DS2 to DS1				X		
DS1 to Voice		X				
DS1 to DS0		X				
DS0 to Subrate*	X					
Transfer Arrangement		X				
Clear Channel Capability		X				
DS3 Premises Multiplexer				X		

* Available only on a circuit of a 1.544 Mbps facility to a Telephone Company hub.

ACCESS SERVICE

7. Special Access Service (Cont'd)

7.11 High Capacity Service (Cont'd)

7.11.5 Rates and Charges (Cont'd)

(A) Circuit Termination
- Per Point of Termination

<u>Jurisdiction</u>	<u>1.544Mbps</u>		
	<u>Monthly Rate</u>	<u>Nonrecurring Charge</u>	
California - Competitive	\$ 86,631.15	\$ 127,731.98	(C)
Texas - Competitive	\$ 78,495.51	\$ 127,731.98	(C)

(B) Circuit Termination - High Capacity DS1 Term Payment Plan#
- Per Point of Termination

<u>Jurisdiction</u>	<u>Nonrecurring Charge</u>	<u>One Year Monthly Rate</u>
All States	Not Available	Not Available

<u>Jurisdiction</u>	<u>Two Year Monthly Rate</u>	<u>Three Year Monthly Rate</u>	<u>Five Year Monthly Rate</u>
All States	Not Available	Not Available	Not Available

(C) Reserved for Future Use

(D) Reserved for Future Use

Service Availability is limited. Refer to # footnote on page 7-30.

ACCESS SERVICE

7. Special Access Service (Cont'd)

7.11 High Capacity Service (Cont'd)

7.11.5 Rates and Charges (Cont'd)

(E) Circuit Termination - High Capacity DS3
- Per Point of Termination

(1) Individual DS3 – Non-capacity System

<u>Jurisdiction</u>	<u>Nonrecurring Charge</u>	(C)
California	\$ 283,848.89	
Texas	\$ 283,848.89	

<u>Jurisdiction</u>	<u>Month to Month Rate ##</u>	<u>One Year # Monthly Rate</u>	(C)
California	\$ 1,338,233.52	Not Available	
Texas	\$ 1,204,909.75	Not Available	

<u>Jurisdiction</u>	<u>Three Year# Monthly Rate</u>	<u>Five Year# Monthly Rate</u>	<u>Seven Year# Monthly Rate</u>
California	Not Available	Not Available	Not Available
Texas	Not Available	Not Available	Not Available

Effective November 19, 2021 DS3 Service Periods are no longer permitted. DS3 Service Period rates in effect as of November 19, 2021 may continue the existing term but will not be eligible to extend, renew, reenroll in, convert to a new term period, or in any other way continue their existing plan beyond its current expiration. At expiration of the commitment term service will be converted to the Month to Month rate. If at any time an existing customer terminates its DS3 Service Period the customer may not re-subscribe to the rate.

Effective July 26, 2022 Any DS3 Service billing at the Month to Month rate will convert to the Individual DS3 – Non-Capacity System Month to Month rate. In addition, at the expiration of a Service Period, the DS3 service will convert to the Individual DS3 – Non-Capacity System Month to Month rate.

ACCESS SERVICE

7. Special Access Service (Cont'd)

7.11 High Capacity Service (Cont'd)

7.11.5 Rates and Charges (Cont'd)

(E) Circuit Termination - High Capacity DS3 (Cont'd)
- Per Point of Termination

(2) Three Capacity System##
- First DS3

<u>Jurisdiction</u>	<u>Nonrecurring Charge</u>		
All States	\$2,500		
<u>Jurisdiction</u>	<u>Month to</u>	<u>One Year#</u>	
	<u>Month Rate ###</u>	<u>Monthly Rate</u>	(C)
California -Competitive	\$5,055.60	\$5,055.60	
Texas - Competitive	\$5,031.40	\$5,031.40	

<u>Jurisdiction</u>	<u>Three Year#</u>	<u>Five Year#</u>	<u>Seven Year#</u>
	<u>Monthly Rate</u>	<u>Monthly Rate</u>	<u>Monthly Rate</u>
California - Competitive	\$3,190.00	\$2,891.90	\$2,704.90
Texas - Competitive	\$3,254.90	\$2,830.30	\$2,638.90

(3) Three Capacity System #- Each Additional DS3 (Maximum of 2)

<u>Jurisdiction</u>	<u>Nonrecurring Charge</u>		
All States	\$1,000.00		
<u>Jurisdiction</u>	<u>Month to</u>	<u>One Year#</u>	
	<u>Month Rate ###</u>	<u>Monthly Rate</u>	(C)
California - Competitive	\$276.10	\$276.10	
Texas - Competitive	\$304.70	\$304.70	

<u>Jurisdiction</u>	<u>Three Year#</u>	<u>Five Year#</u>	<u>Seven Year#</u>
	<u>Monthly Rate</u>	<u>Monthly Rate</u>	<u>Monthly Rate</u>
California -Competitive	\$203.50	\$200.20	\$191.40
Texas - Competitive	\$217.80	\$193.60	\$182.60

Service Offering is further limited. See footnote on page 7-87 (N)

Service Availability is limited. Refer to # footnote on page 7-43.

Service Offering is limited. See footnote on page 7-87

ACCESS SERVICE

7. Special Access Service (Cont'd)

7.11 High Capacity Service (Cont'd)

7.11.5 Rates and Charges (Cont'd)

(E) Circuit Termination - High Capacity DS3 (Cont'd)
- Per Point of Termination

(4) Twelve Capacity System##
- First DS3

<u>Jurisdiction</u>	<u>Nonrecurring Charge</u>		
All States	\$4,500		
<u>Jurisdiction</u>	<u>Month to</u>	<u>One Year#</u>	
	<u>Month Rate ###</u>	<u>Monthly Rate</u>	(C)
California - Competitive	\$7,717.60	\$7,717.60	
Texas - Competitive	\$7,812.20	\$7,812.20	

<u>Jurisdiction</u>	<u>Three Year#</u>	<u>Five Year#</u>	<u>Seven Year#</u>
	<u>Monthly Rate</u>	<u>Monthly Rate</u>	<u>Monthly Rate</u>
California - Competitive	\$5,618.34	\$5,216.20	\$4,956.60
Texas -Competitive	\$5,691.40	\$5,098.50	\$4,822.40

(5) Twelve Capacity System#
- Each Additional DS3 (Maximum of 11)

<u>Jurisdiction</u>	<u>Nonrecurring Charge</u>		
All States	\$1,000.00		
<u>Jurisdiction</u>	<u>Month to</u>	<u>One Year#</u>	
	<u>Month Rate ###</u>	<u>Monthly Rate</u>	(C)
California - Competitive	\$276.10	\$276.10	
Texas - Competitive	\$304.70	\$304.70	

<u>Jurisdiction</u>	<u>Three Year#</u>	<u>Five Year#</u>	<u>Seven Year#</u>
	<u>Monthly Rate</u>	<u>Monthly Rate</u>	<u>Monthly Rate</u>
California - Competitive	\$218.90	\$200.20	\$191.40
Texas -Competitive	\$217.80	\$193.60	\$182.60

Service Offering is further limited. See footnote on page 7-87 (N)

Service Availability is limited. Refer to # footnote on page 7-43.

Service Offering is limited. See footnote on page 7-87

ACCESS SERVICE

7. Special Access Service (Cont'd)

7.11 High Capacity Service (Cont'd)

7.11.5 Rates and Charges (Cont'd)

(F) Circuit Termination - Frequency bandwidths other than 1.544 Mbps (DS1) and 44.736 Mbps (DS3)

- Per Point of Termination

Frequency bandwidths other than 1.544 Mbps:

Monthly Rates and Nonrecurring Charges for the Circuit Termination rate element of High Capacity Service for all jurisdictions of the Issuing Carriers listed on the Title Pages will be determined on an Individual Case Basis and filed in Section 7.12 following.

Available frequency bandwidths are as follows:

Frequency
Bandwidths

64 Kbps
3.152 Mbps
6.312 Mbps
274.176 Mbps

ACCESS SERVICE

7. Special Access Service (Cont'd)

7.11 High Capacity Service (Cont'd)

7.11.5 Rates and Charges (Cont'd)

(G) Circuit Mileage - High Capacity DS1

1.544Mbps

<u>Jurisdiction</u>	<u>Monthly Rate Fixed</u>	<u>Monthly Rate Per Mile</u>	
California	\$ 11,266.59	\$ 3,036.89	(C)
Texas	\$ 8,495.28	\$ 1,901.75	(C)
<u>Disconnect Non-Recurring Charge</u>			
per Circuit	All Jurisdictions All terms	\$975.00	

(H) Reserved for Future Use

(I) Reserved for Future Use

ACCESS SERVICE

7. Special Access Service (Cont'd)

7.11 High Capacity Service (Cont'd)

7.11.5 Rates and Charges (Cont'd)

(J) DS3 Circuit Mileage

(1) Circuit Mileage - High Capacity DS3

<u>Jurisdiction</u>	<u>Monthly Rate</u>	
	<u>Fixed</u>	<u>Per Mile</u>
California	\$ 253,008.40	\$ 25,362.03
Texas	\$ 124,893.41	\$ 13,298.80

(C)

(2) Banded Circuit Mileage - High Capacity DS3

<u>Jurisdiction</u>	<u>Monthly Rate</u>
<u>Texas</u>	
1-4 Miles	\$ 156,117.50
5-8 Miles	\$ 221,685.74
9-15 Miles	\$ 305,988.80
16-25 Miles	\$ 351,262.72
26-40 Miles	\$ 430,882.25
41 Miles or More	\$ 764,972.56

(C)

Disconnect Non-Recurring Charge
per Circuit All Jurisdictions All terms \$975.00

ACCESS SERVICE

7. Special Access Service (Cont'd)

7.11 High Capacity Service (Cont'd)

7.11.5 Rates and Charges (Cont'd)

(K) Circuit Mileage - For frequency bandwidths other than 1.544 Mbps (DS1) and 44.736 Mbps (DS3):

Fixed and Per Mile Monthly Rates for the Circuit Mileage rate element of High Capacity Service for all jurisdictions of the Issuing Carriers listed on the Title Pages will be determined on an Individual Case Basis and filed in Section 7.12 following.

Available frequency bandwidths are as follows.

Frequency
Bandwidths

64 Kbps
3.152 Mbps
6.312 Mbps
274.176 Mbps

ACCESS SERVICE

7. Special Access Service (Cont'd)

7.11 High Capacity Service (Cont'd)

7.11.5 Rates and Charges (Cont'd)

(L) Optional Features and Functions

Rates and charges for the Optional Features and Functions of High Capacity Service listed in this section apply to all jurisdictions of the Issuing Carriers listed on the Title Pages.

	<u>Monthly Rates</u>	<u>Nonrecurring Charges</u>	
(1) <u>Multiplexing</u>			
DS4 to DS1			
- Per arrangement			
California	ICB	None	
Texas	ICB	None	
DS2 to DS1			
- Per arrangement			
California	ICB	None	
Texas	ICB	None	
DS1 TO DSO			
- Per arrangement			
California	\$ 89,193.68	None	(C)
Texas	\$ 89,193.68	None	(C)
DS0 to Subrates			
- Per arrangement			
Up to 20 2.4 Kbps services			
California	\$ 21,907.11	None	
Texas	\$ 21,907.11	None	
Up to 10 4.8 kbps services			
California	\$ 16,430.19	\$ 109,535.25	
Texas	\$ 16,430.19	\$ 109,535.25	
Up to 5 9.6 kbps services			
California	\$ 13,691.86	\$ 109,535.25	
Texas	\$ 13,691.86	\$ 109,535.25	

ACCESS SERVICE

7. Special Access Service (Cont'd)

7.11 High Capacity Service (Cont'd)

7.11.5 Rates and Charges (Cont'd)

(L) Optional Features and Functions (Cont'd)

(1) Multiplexing (Cont'd)

DS1 to Voice Multiplexing*
- Per arrangement

<u>Jurisdiction</u>	<u>Monthly Rates</u>	<u>Nonrecurring Charges</u>
California	\$ 56,516.71	\$ 227,078.86
Texas	\$ 56,516.71	\$ 227,078.86

(C)

DS3 to DS1 Multiplexing
- Per arrangement

<u>Jurisdiction</u>	<u>Monthly Rates</u>	<u>Nonrecurring Charges</u>
California	\$ 105,849.98	\$ 127,731.98
Texas	\$ 141,291.50	\$ 127,731.98

DS3 Premises Multiplexer
- Per arrangement

<u>Jurisdiction</u>	<u>Monthly Rates</u>	<u>Nonrecurring Charges</u>
California	\$ 141,924.12	\$ 149,020.57
Texas	\$ 141,924.12	\$ 149,020.57

(C)

* A circuit of this DS1 to the hub can be used for Digital Data service.

ACCESS SERVICE

7. Special Access Service (Cont'd)

7.11 High Capacity Service (Cont'd)

7.11.5 Rates and Charges (Cont'd)

(L) Optional Features and Functions (Cont'd)

	<u>Monthly Rates</u>	<u>Nonrecurring Charges</u>	
(2) Automatic Loop Transfer - Per arrangement*			
California	\$100.00	None	
Texas	\$100.00	None	
(3) Transfer Arrangement (key activated** or dial up***) - Per four port arrangement including control channel termination****)			
California	\$165.00	None	
Texas	\$165.00	None	
(4) Clear Channel Capability - Per DS1 circuit arranged			
California	None	\$ 227,078.86	(C)
Texas	None	\$ 227,078.86	(C)

* An additional Circuit Termination charge will apply whenever the spare line is provided as a leg to the customer premises.

** The key activated control circuit is rated as a Voice Grade Circuit Termination and Circuit Mileage, if applicable.

*** The Dial-up option requires the customer to purchase the Controller Arrangement from 13.3.8 following.

**** An additional Circuit Termination charge will apply whenever a spare circuit is configured as a leg to the customer's premises. Additional circuit mileage charges will also apply when the transfer arrangement is not located in the customer premises serving wire center.

ACCESS SERVICE

7. Special Access Service (Cont'd)

7.11 High Capacity Service (Cont'd)

7.11.5 Rates and Charges (Cont'd)

(M) Special Access Cross Connect

Per DS0, DS1 or DS3 Connection

<u>State</u>	<u>DS0 Monthly Rate</u>	<u>DS1 Monthly Rate</u>	<u>DS3 Monthly Rate</u>
California	\$3.05	\$8.69	\$75.63
Texas	1.59	3.63	24.77

ACCESS SERVICE

7. Special Access Service (Cont'd)

7.12 RESERVED

ACCESS SERVICE

7. Special Access Service (Cont'd)

7.12 RESERVED

ACCESS SERVICE

7. Special Access Service (Cont'd)

7.12 RESERVED

ACCESS SERVICE

- 7. Special Access Service (Cont'd)
 - 7.12 RESERVED (Cont'd)

ACCESS SERVICE

7. Special Access Service (Cont'd)

7.13 High Voltage Protection

7.13.1 Description

High Voltage Protection is used at customer locations that may require special equipment to isolate or neutralize Ground Potential Rise (GPR) and/or induced voltage caused by faults in the electric power system. GPR is a voltage difference between two or more ground electrodes caused by earth return currents. GPR on cable facilities can occur, for example, when current from lightning surges flow to ground, but GPR often is associated with voltage generated as the power system fault currents flow to ground. Maximum GPR is developed by the percentage of line-to-ground fault current entering earth through electrode impedance.

This feature will provide high voltage isolation for Special Access telecommunications, while enabling the normal transmission between the Telephone Company wire center and the equipment at the customer's location during GPR environment due to electrical power faults.

7.13.2 Provisioning

The Telephone Company shall determine the proper levels of protection required on its network to isolate or neutralize electrical hazard, based on the information provided by the customer. The customer shall provide the Telephone Company, in writing, the technical data necessary for the Telephone Company to determine the high voltage protection requirements, at the time of application for the initial service, additions to, or changes in the existing service. In addition, the customer shall notify the Telephone Company before making changes in the electric supply that will increase the GPR at the location.

The technical data for the customer's location shall include, but not be limited to, the following:

- ground grid area in square feet
- ground grid impedance in ohms
- X/R ratios at worst case fault location
- GPR in volts MS

ACCESS SERVICE

7. Special Access Service (Cont'd)

7.13 High Voltage Protection (Cont'd)

7.13.2 Provisioning (Cont'd)

Based on the customer's technical data provided to the Telephone Company, the Telephone Company will provide the necessary high voltage protection equipment at the Telephone Company's demarcation point on the customer's premises and at the remote drainage location. The placement of the equipment by the Telephone Company shall in no way release the customer of its responsibility for damage, loss or claims caused by electrical hazards resulting from the customer's electric power system. The Telephone Company's liability for damage, loss or claims is set forth under 2.3.1.

The customer may elect to furnish the equipment at its premises to isolate or neutralize the electrical hazard subject to the approval of the Telephone Company; however, such approval by the Telephone Company shall not relieve the customer of its responsibility to install or maintain adequate high voltage equipment. The high voltage protection equipment at the customer's location will be exclusively owned either by the Telephone Company or by the customer.

When the customer provides the high voltage equipment at its premise, the Telephone Company will provide the necessary high voltage equipment at the wire center and remote drainage location. The Telephone Company will be responsible up to and including the network interface for the termination of Special Access Services regardless of ownership of the high voltage protection equipment.

The Telephone Company will inspect and verify adequacy of the high voltage protection equipment when service is established and at such future times as deemed necessary due to additions, deletions, rearrangements, routine maintenance or for the purpose of verifying the adequacy of the high voltage protection equipment.

ACCESS SERVICE

7. Special Access Service (Cont'd)

7.13 High Voltage Protection (Cont'd)

7.13.3 Claims and Demands for Damage

In addition to the provisions in Section 2.3.8, the customer shall defend, indemnify and save harmless the Telephone Company from any and all loss, claims, demands, suits or other action or any liability whatsoever, whether suffered, made, instituted or asserted by the customer or by any other party or person, for any personal injury to or death of any person or persons, or for any loss, damage or destruction of any property whether owned by the customer or others, caused or claimed to have been caused directly or indirectly by the installation, operation, failure to operate, maintenance, removal, presence, condition, location or use of such equipment and services associated with high voltage protection equipment furnished by the Telephone Company or with customer equipment when combined or connected with facilities of the Telephone Company.

Services provided by the Telephone Company shall not cause the Telephone Company to become responsible for damage, loss or claims caused by electrical hazards resulting from a customer's electric power system.

7.13.4 Network Outage

Interruptions or outages of services provided to customers may occur for reasons, such as facility damage due to storm loading, vehicle accident, lightning strike, or other acts of God. Circuit failures caused by such events cannot be prevented by services provided in accordance with this service (however, interruptions and service outages due to fault-produced ground potential rise and induction can be minimized). The Telephone Company expressly states that provision of the high voltage equipment cannot prevent such service outages as may normally occur due to the proceeding circumstances. It is the responsibility of the customer to provide sufficient protection to prevent damage caused by such events.

Interruptions or outages due to the effects (GPR and/or induction) of faults in the customer's power generating, transmission and/or distribution system are minimized through the installation and maintenance of high voltage protection equipment which is designed to operate in a fault-produced electrical environment.

ACCESS SERVICE

7. Special Access Service (Cont'd)

7.13 High Voltage Protection (Cont'd)

7.13.5 Compliance Statement

If the Telephone Company has provided service where high voltage protection is necessary, by the customer or the customer-provided equipment is nonfunctional or inadequate or the customer fails, upon written notice, to establish or reestablish the required high voltage protection equipment or apply for and obtain such protection from the Telephone Company, or keep the Telephone Company informed of changed high voltage requirements, then the Telephone Company will disconnect service 120 days after giving the notice required, as set forth under Section 2.1.8(A).

7.13.6 Rate Regulations

(A) Minimum Period

The minimum period for High Voltage Protection is one month.

(B) Rate Elements

(1) Initial Common Equipment

A nonrecurring charge and a monthly rate apply for the Initial Common (basic) Equipment used for the physical connection to the network interface. The Initial Common Equipment can accommodate up to eight Special Access facility terminations at a customer's location.

(2) High Voltage Terminating Equipment

High Voltage Terminating Equipment is required for each Special Access facility termination. A nonrecurring charge and a monthly rate for the High Voltage Terminating Equipment apply in addition to the rates and charges for the Special Access facility as well as the associated Special Access Service regulations.

ACCESS SERVICE

7. Special Access Service (Cont'd)

7.13 High Voltage Protection (Cont'd)

7.13.7 Rates and Charges

<u>Jurisdiction</u>	<u>Initial Common Nonrecurring Charge</u>	<u>Equipment Monthly Rate</u>	<u>Terminating Equipment, Per Circuit Terminated Nonrecurring Charge</u>	<u>Monthly Rate</u>
California	\$500.00	\$108.22	\$50.00	\$28.81
Texas	500.00	108.22	50.00	28.81

7.14 Reserved for Future Use

ACCESS SERVICE

7. Special Access Service (Cont'd)

7.15 Bonded Digital Link Service

7.15.1 Description

Bonded Digital Link Service provides connecting channels for the transmission of voice or data between an end user's local exchange service terminating at a digital cross connect facility and special access service provided by the Telephone Company within the same wire center or at another wire center within the same LATA.

Bonded Digital Link Service is comprised of Intra-office channels (channels within a single wire center) or Inter-office channels (channels between two wire centers) connecting the wire centers of the locations involved. The minimum transmission rate for the service is 64 kbps in a DSO channel. The Telephone Company will provide for the transmission of DS0 channels within a DS1 signal of the customer's (the end user) associated local exchange service from the digital cross connect facility in the customer's serving wire center to a 64 kbps channel of a customer's DS1 to Digital central office multiplexing arrangement within the same wire center or in a different wire center. The total number of DS0s on a Bonded Digital Link Service channel may not exceed the total capacity of the DS1 or equivalent service to which it is connected.

At the customer's option, the Telephone Company will bond contiguous DS0 channels in order to provide higher data rates. The following data rates are available:

- 64 kbps; 1 DS0 equivalent channel
- 128 kbps; 2 DS0 equivalent channel
- 256 kbps; 4 bonded equivalent DS0s
- 384kbps; 6 bonded equivalent DS0s
- 512 kbps; 8 bonded equivalent DS0s
- 768 kbps; 12 bonded equivalent DS0s

For the transmission of the Bonded Digital Link channels, the Telephone Company assumes responsibility for the routing of the customer's DS0 and bonded DS0 circuits over the Telephone Company's interoffice network in order to maximize network efficiencies and to optimize economic efficiencies.

ACCESS SERVICE

7. Special Access Service (Cont'd)

7.15 Bonded Digital Link Service (Cont'd)

7.15.2 Terms and Conditions

- (1) Bonded Digital Link Service is available within or between wire centers where suitable digital cross-connect technology exists to perform DS1 to DS0 multiplexing functions. Those locations (wire centers) are set forth in NATIONAL EXCHANGE CARRIER ASSOCIATION, INC. TARIFF FCC NO. 4.
- (2) The service may only be used for connection from a wire center with a digital hubbing arrangement to a DS1 special access service capable of assignment to compatible DS0 channels. The customer or its authorized representatives must designate the DS0 channels on the special access service connected to this service. Data rates above 64 kbps require contiguous DS0 channel assignments. Connection to services other than special access service is prohibited.
- (3) Bonded Digital Link Service is provided with a one-year minimum service period. If service is disconnected prior to satisfying the minimum service period (i.e., within the first twelve months), minimum period charges apply. The minimum one-year period and minimum period charges do not apply if the rates have increased during the one-year period. The minimum period charge is equal to 100 % of the monthly rate from the date of disconnection through the balance of the first twelve months of service.
- (4) This service is used for connectivity within or between wire centers. The rates and charges for Bonded Digital Link Service apply as a flat rate per DS0 equivalent channel.
- (5) Credit for an interruption of Bonded Digital Link Service is subject to the basic credit allowance set forth for Special Access services as set forth in Section 2.7.1.1 preceding.
- (6) Bonded Digital Link Service is provided according to service date intervals as set forth in Section 5.1.7 preceding.
- (7) The rates and charges for Bonded Digital Link Service apply per DS0 equivalent channel (64 kbps). The customer is assessed either an Intra-office or an Inter-office Channel Charge for each DS0.

ACCESS SERVICE

7. Special Access Service (Cont'd)

7.15 Bonded Digital Link Service (Cont'd)

7.15.3 Rates and Charges

	<u>Monthly Rates</u>
Intra-office Channel - Per DS0 Texas	\$3.00
Inter-office Channel - Per DS0 Texas	\$7.00

ACCESS SERVICE

8. Miscellaneous Services

In this section normally scheduled working hours shall mean the Business. Basic Time is that time during the Business Day. Overtime is that time outside the Business day and all day Saturday. Premium Time is that time all day on Sunday and Telephone Company observed holidays.

A call-out of a Telephone Company employee at a time not consecutive with Business Day is subject to a minimum charge of four hours.

8.1 Additional Engineering

Additional Engineering will be provided by the Telephone Company at the request of the customer or when the Telephone Company determines that Additional Engineering is necessary to accommodate a customer's request.

Additional Engineering is provided when:

- (A) A customer requests additional technical information beyond that normally included by the Telephone Company on the Design Layout Report (DLR) as set forth in 6.4(F) and 7.1.6.
- (B) Additional engineering time is incurred by the Telephone Company to engineer a customer's specific written request for a customized service or additional engineering activities which are not normally performed in the provision of services under this Guide.

The Telephone Company will notify the customer that Additional Engineering charges, as set forth in 8.1.1 following, will apply before any additional engineering is undertaken. When it is required, the customer will be so notified and will be furnished with a written statement setting forth the justification for the Additional Engineering as well as an estimate of the charges. If the customer agrees to the Additional Engineering, a firm order will be established. If the customer does not want the service or facilities after being notified that Additional Engineering of Telephone Company facilities is required, the order will be withdrawn and no charges will apply. Once a firm order has been established, the total charge to the customer for the Additional Engineering may not exceed the estimated amount by more than 10%.

ACCESS SERVICE

8. Miscellaneous Services (Cont'd)

8.1 Additional Engineering (Cont'd)

8.1.1 Charges for Additional Engineering

The charges for Additional Engineering are as follows:

Per Engineer, Per Half Hour, or Fraction Thereof

<u>Jurisdiction</u>	<u>Basic Time</u>	<u>Overtime</u>	<u>Premium Time</u>
California	\$150.00	\$200.00	\$250.00
Texas	150.00	200.00	250.00

ACCESS SERVICE

8. Miscellaneous Services (Cont'd)

8.2 Additional Labor

Additional labor is that labor requested and authorized by the customer on a given service and agreed to by the Telephone Company as set forth in 8.2.1 through 8.2.5 following. The Telephone Company will notify the customer that additional labor charges as set forth in 8.2.7 following will apply before any additional labor is undertaken. Charges for additional labor will apply per order submitted.

8.2.1 Overtime Installation

Overtime installation is that Telephone Company installation effort performed outside the Business Day.

8.2.2 Overtime Repair

Overtime repair is that Telephone Company maintenance effort performed outside the Business Day.

8.2.3 Stand by

Stand by includes all time in excess of one-half (1/2) hour during which Telephone Company personnel stand by to make installation acceptance tests or cooperative tests with a customer on a given service.

8.2.4 Maintenance with Other Telephone Companies

Additional labor charges apply to additional maintenance or repair of facilities which connect to facilities of other telephone companies. This is in addition to the normal efforts required to maintain or repair facilities provided solely by the Telephone Company, as set forth in 2.1.1(C).

8.2.5 Other Labor

Other labor is that additional labor not included in 8.2.1 through 8.2.4 preceding. This includes labor incurred to accommodate a specified customer request that involves only labor which is not covered by any other section of this Guide.

ACCESS SERVICE

8. Miscellaneous Services (Cont'd)

8.2 Additional Labor

8.2.6 Charges for Additional Labor

The charges for Additional Labor are as follows:

Per Technician, Per Half Hour, or Fraction Thereof
Maintenance and Other Labor (See Sections 8.2.4, 8.2.5, and 8.3(C)).

<u>Jurisdiction</u>	<u>Basic Time</u>	<u>Overtime*</u>	<u>Premium Time*</u>
California	\$150.00	\$200.00	\$250.00
Texas	150.00	200.00	250.00

Per Technician, Per Half Hour, or Fraction Thereof
Installation or Repair (See Sections 8.2.1 through 8.2.2)

<u>Jurisdiction</u>	<u>Basic Time</u>	<u>Overtime*</u>	<u>Premium Time*</u>
California	\$21.87	\$75.00	\$125.00
Texas	20.83	75.00	125.00

Per Technician, Per Half Hour, or Fraction Thereof
Stand by (See Section 8.2.3)

<u>Jurisdiction</u>	<u>Basic Time</u>	<u>Overtime*</u>	<u>Premium Time*</u>
California	\$60.00	\$70.00	\$80.00
Texas	60.00	70.00	80.00

* A call-out of a Telephone Company employee at a time not consecutive with the Business Day is subject to a minimum charge of four hours.

ACCESS SERVICE

8. Miscellaneous Services (Cont'd)

8.3 Maintenance of Service

- (A) The customer will be responsible for reporting troubles sectionalized to Telephone Company facilities and/or equipment. When trouble cannot be clearly sectionalized to the Telephone Company facilities and/or equipment, the Telephone Company will test cooperatively or independently to assist in trouble sectionalization.

When a customer reports a trouble to the Telephone Company for clearance and no trouble is found in the Telephone Company's facilities, the customer shall be responsible for payment of a Maintenance of Service charge for the period of time from when Telephone Company personnel are dispatched to the customer's or customer's end user premises to when the work is completed. Failure of Telephone Company personnel to find trouble in Telephone Company facilities will result in no charge if the trouble is actually in those facilities, but not discovered at the time.

- (B) The customer shall be responsible for payment of a Maintenance of Service charge when the Telephone Company dispatches personnel to the customer's premises, and the trouble is in equipment or communications systems provided by other than the Telephone Company or in detariffed CPE provided by the Telephone Company.

In either (A) or (B) preceding, no credit allowance will be applicable for the interruption involved if the Maintenance of Service Charge applies.

- (C) The charge for Maintenance of Service are as follows:

Maintenance
of Service
Periods

Per Technician

Per occurrence

The charges for Maintenance of Service are the same as those set for Additional Labor as set forth in 8.2 preceding.

ACCESS SERVICE

8. Miscellaneous Services (Cont'd)

8.4 Additional Testing

Testing Services provides for the use of a Telephone Company technician in performing specific tests authorized by the customer including additional testing of facilities which connect to facilities of other telephone companies. Testing Services offered under this section of the tariff are optional and are in addition to acceptance tests and in-service tests performed by the Telephone Company as described in 6.4 (G) and 7.1.7 preceding. Testing Services are made subject to the availability of the necessary qualified personnel and test equipment at the requested test locations.

Testing Services consist of Additional Cooperative Acceptance Testing (ACAT) which is performed during installation of Access Services and Nonscheduled Testing (NST) which is performed after acceptance of Access Services by the customer. Rates and charges for Testing Service are set forth in 8.4(C) following.

The Telephone Company will provide, upon request, documentation that lists the results of the tests performed. Trunk test failures requiring customer participation for trouble resolution will be provided to the customer on an as-occurs basis.

(A) Additional Cooperative Acceptance Testing

Rates and charges for Additional Cooperative Acceptance Testing of Special Access Services apply per technician used.

ACCESS SERVICE

8. Miscellaneous Services (Cont'd)

8.4 Additional Testing (Cont'd)

(A) Additional Cooperative Acceptance Testing (Cont'd)

(1) Special Access Service

When a customer provides a technician at its premises or at an end user's premises, with suitable test equipment to perform the requested tests, the Telephone Company may provide a technician at its office for the purpose of conducting Additional Cooperative Acceptance Testing on Voice Grade Services at the time of installation. At the customer's request, the Telephone Company may provide a technician at the customer's premises or at the end user premises: These tests may, e.g., consist of the following:

- Attenuation Distortion (i.e., frequency response)
- Intermodulation Distortion (i.e., harmonic distortion)
- Phase Jitter
- Impulse Noise
- Envelope Delay Distortion
- Echo Control
- Frequency Shift

(B) Nonscheduled Testing

Nonscheduled tests are performed by the Telephone Company "on demand." When a customer provides a technician at its premises with suitable test equipment to perform the required tests, the Telephone Company may provide a technician at its office for the purpose of conducting Nonscheduled Testing of Special Access services. At the customer's request, the Telephone Company may provide a technician at the customer's premises. Nonscheduled tests may consist of any tests, e.g., loss, noise, slope, envelope delay, which the customer may require. Rates and charges for Nonscheduled Testing apply per technician used.

ACCESS SERVICE

8. Miscellaneous Services (Cont'd)

8.4 Additional Testing (Cont'd)

(C) Rates and Charges

The charges for Additional Testing are as follows:

Per Technician, Per Half Hour, or Fraction Thereof

<u>Jurisdiction</u>	<u>Basic Time</u>	<u>Overtime*</u>	<u>Premium Time*</u>
California	\$150.00	\$200.00	\$250.00
Texas	150.00	200.00	250.00

* A call-out of a Telephone Company employee at a time not consecutive with the Business Day is subject to a minimum charge of four hours.

ACCESS SERVICE

8. Miscellaneous Services (Cont'd)

8.5 RESERVED

8.6 RESERVED

8.7 RESERVED

ACCESS SERVICE

8. Miscellaneous Services (Cont'd)

8.8 Telecommunications Service Priority

8.8.1 General

The Telephone Company will arrange a Telecommunications Service Priority (TSP) installation and service restoration classification on receipt of certification in conformance with Part 64, Subpart D, Appendix A of the Federal Communications Commission's Rules and Regulations.

The TSP System is a service, developed to meet the requirements of the Federal Government, for the priority installation and/or restoration of NSEP telecommunications services. These include Special Access Services. The TSP System applies only to NSEP telecommunications services and requires and authorizes priority action by the Telephone Company.

The TSP System shall be provided in accordance with the guidelines set forth in Technical References Telecommunications Service Priority (TSP) System for National Security Emergency Preparedness (NSEP) Service Vendor Handbook (NCS) H 3-1-2 and Telecommunications Service Priority (TSP) System for National Security Emergency Preparedness (NSEP) Service User Manual (NCS) M 3-1-1.

8.8.2 Priority Installation

Expedited order charges, as set forth in Section 5.3.1.(D), are applicable to access orders submitted with a TSP installation priority. Access orders requiring the special construction of facilities will be subject to special construction regulations, rates and charges as set forth in Section 5.1.12 preceding.

ACCESS SERVICE

8. Miscellaneous Services (Cont'd)

8.8 Telecommunications Service Priority (Cont'd)

8.8.3 Priority Restoration

- (A) New orders with priority level assignments will be provisioned in accordance with the guidelines established for TSP. The Telephone Company will not accept orders for new Restoration Priority System (RP) circuits after September 10, 1990. Applications for circuits previously provisioned under RP must be resubmitted for provisioning in accordance with the guidelines established for TSP during the 30-month transition period between September 10, 1990 through March 10, 1993. The Nonrecurring Charge as set forth in 8.8.4(B) will apply to RP orders resubmitted for provisioning under the TSP System. After the transition period, the Telephone Company will discontinue any RP assignments remaining on record.
- (B) Under certain conditions it may be necessary to preempt one or more customer services with a lower or no restoration priority in order to install or restore NSEP telecommunications service(s) of a higher priority. If such preemption is necessary, and if circumstances permit, the Telephone Company will make reasonable effort to notify the preempted service customer of the action to be taken.
- (C) No additional charge applies to the implementation of a Priority Restoration level submitted concurrent with the initial order to install the Special Access Service. The nonrecurring charge set forth in 8.8.4(B) following will apply to any request to change or add a Priority Restoration level on an existing Special Access Service.

ACCESS SERVICE

8. Miscellaneous Services (Cont'd)

8.8 Telecommunications Service Priority (Cont'd)

8.8.4 Rates and Charges

The following rates and charges are in addition to all other rates and charges that may be applicable for other services that may be furnished the provisions of this Guide which operate in conjunction with the TSP System.

(A) Priority Installation of an Access Service.

- | | |
|--|--|
| (1) Expedited Orders | Regulations, rates and charges are the same as those set forth in 5.3.1(D) preceding for Special Access Service. |
| (2) Utilization of Specially Constructed Facilities. | Regulations, rates and charges as set forth in Section 5.1.12 preceding. |

(B) Priority Restoration (PR) Level Implementation on an Access Service.

	<u>Monthly Rates</u>	<u>Nonrecurring Charges</u>
(1) When the PR level is implemented concurrent with the initial ASR.	None	
(2) When the PR level is added or changed on an existing Access Service.	\$4.90	\$14.50

ACCESS SERVICE

9. RESERVED FOR FUTURE USE

ACCESS SERVICE

10. RESERVED FOR FUTURE USE

ACCESS SERVICE

11. Special Facilities Routing of Access Services

11.1 Description of Special Facilities Routing of Access Services

The services provided under this Guide are provided over such routes and facilities as the Telephone Company may elect. Special Facilities Routing is involved when, in order to comply with requirements specified by the customer, the Telephone Company provides Special Access Service in a manner which includes one or more of the following conditions:

11.1.1 Diversity

Two or more services must be provided over not more than two different physical routes. Diversity is a Basic Service Element (BSE) under the Telephone Company's Open Network Architecture (ONA) Plan.

11.1.2 Avoidance

A service must be provided on a route which avoids specified geographical locations.

11.1.3 Cable-Only Facilities

Certain Voice Grade services are provided on Cable-Only Facilities to meet the particular needs of a customer.

Service is provided subject to the availability of Cable-Only facilities. In the event of service failure, restoration will be made through the use of any available facilities as selected by the Telephone Company.

Avoidance and Diversity are available on Special Access Services as set forth in 7. preceding. Cable-Only Facilities are available for Voice Grade Special Access Services as set forth in 7.5 preceding.

In order to avoid the compromise of special routing information, the Telephone Company will provide the required routing information for each specially routed service to only the ordering customer. If requested by the customer, this information will be provided when service is installed and prior to any subsequent changes in routing.

ACCESS SERVICE

11. Special Facilities Routing of Access Services (Cont'd)

11.2 Rates and Charges for Special Facilities Routing of Access Service

The rates and charges for Special Facilities Routing of Access Services as set forth in 11.2 following are in addition to all other rates and charges that may be applicable for services provided under other sections of this Guide.

11.2.1 Diversity

For each service provided in accordance with 11.1.1 preceding, the rates and charges will be developed on an individual case basis and filed following:

11.2.2 Avoidance

For each service provided in accordance with 11.1.2 preceding, the rates and charges will be developed on an individual case basis and filed following:

ACCESS SERVICE

11. Special Facilities Routing of Access Services (Cont'd)

11.2 Rates and Charges for Special Facilities Routing of Access Service (Cont'd)

11.2.3 Diversity and Avoidance Combined

For each service provided in accordance with 11.1.1 and 11.1.2 preceding, combined, the rates and charges will be developed on an individual case basis and filed following:

11.2.4 Cable-Only Facilities

For each service provided in accordance with 11.1.3 preceding, the rates and charges will be developed on an individual case basis and filed following:

ACCESS SERVICE

12. Specialized Service or Arrangements

12.1 General

Specialized Service or Arrangements may be provided by the Telephone Company, at the request of a customer, on an individual case basis if such service or arrangements meet the following criteria:

- The requested service or arrangements are not offered under other sections of this Guide.
- The facilities utilized to provide the requested service or arrangements are of a type normally used by the Telephone Company in furnishing its other services.
- The requested service or arrangements are provided within a LATA.
- The requested service or arrangements are compatible with other Telephone Company services, facilities, and its engineering and maintenance practices.
- This offering is subject to the availability of the necessary Telephone Company personnel and capital resources.

12.2 RESERVED

ACCESS SERVICE

13. RESERVED FOR FUTURE USE

ACCESS SERVICE

14. RESERVED FOR FUTURE USE

ACCESS SERVICE

15. RESERVED FOR FUTURE USE

ACCESS SERVICE

16. RESERVED FOR FUTURE USE

ACCESS SERVICE

17. RESERVED FOR FUTURE USE

ACCESS SERVICE

18. RESERVED FOR FUTURE USE

ACCESS SERVICE

19. RESERVED FOR FUTURE USE

ACCESS SERVICE

20. OPTICAL NETWORKING

(A) General

This section contains the rules and regulations pertaining to the provisioning of SONET Access and Dense Wave Division Multiplexing (DWDM) Service. The regulations and rates specified herein are in addition to the applicable rates and regulations specified in other Sections of this Guide.

This service supports asynchronous bandwidth capacities at 1.5 Mbps and 45 Mbps in addition to synchronous Optical Carrier (OC) bandwidth capacities at OC3, OC3c, OC12, OC12c, OC48, OC48c and OC192 bit rates and 1.25 Gbps or 2.5 Gbps wavelengths. The SONET add/drop multiplexer aggregates lesser bit speed services onto the dedicated SONET ring or the two-point SONET circuit configuration.

(B) Description

Optical Networking is comprised of high speed SONET based and/or DWDM technology providing connectivity at, and transport between, two or more customer designated locations (CDLs). Additionally, certain Optical Networking services provide interconnection between an EIS arrangement and a Telephone Company wire center associated with certain Optical Networking Service or advanced data service*.

* Advanced data services include Telephone Company provided frame relay services, switched multi-megabit services, Internet Protocol services, LAN Extension Services and ATM-cell relay services. Connections to advanced data services are provided by the Telephone Company where such connections are technically and operationally feasible, as determined by the Telephone Company.

ACCESS SERVICE

20. OPTICAL NETWORKING (Cont'd)

(C) Conditions

Optical Networking services are provided where facilities are available with sufficient bandwidth capacity to meet the customer's request.

The customer is responsible for providing all facilities and cabling necessary to connect customer equipment to this interface.

Customer Facility Assignment (CFA) is controlled by the Telephone Company, on all non-interexchange access customer serving wire centers on the IOF and extends to the terminating CDL. Should the customer require control of the facility assignment and order multiplexing on the IOF, the services from the multiplexer to the end user serving wire center will be ordered from Section 7 of this Guide.

It is the customer's responsibility to ensure that the customer's equipment provides industry standard electrical signals compatible with Optical Networking transport transmission. Technical specifications are contained in the following Technical References:

GR-253-CORE, Issue 4
GR-1400-CORE, Issue 3
GR-1374-CORE, Issue 1
ANSI T1.105.01-2000 (R2005)
ANSI T1.102-1993 (R2005)

The Company will work cooperatively with the customer during a planning session to insure that the customer orders sufficient Optical Networking bandwidth capacity to satisfy the customer's requirements as well as other applicable Optical Networking services. This planning session must take place prior to an initial Optical Networking ASR.

ACCESS SERVICE

20. OPTICAL NETWORKING (Cont'd)

(D) Application of Rates and Charges

The Connect rate element provides the platform for customer access to the Telephone Company's Optical Network. The Connect element provides the link between the CDL and the SWC of the CDL.

(1) There are two types of Connects:

Express Connect #

Flex Express Connect ##

(a) Reserved for Future Use

(b) Reserved for Future Use

(c) Reserved for Future Use

(d) Reserved for Future Use

(e) Reserved for Future Use

(f) Reserved for Future Use

(g) Reserved for Future Use

Service availability limited. Refer to # footnote on Page 20-4.

Service availability limited. Refer to # footnote on Page 20-5.

ACCESS SERVICE

20. OPTICAL NETWORKING (Cont'd)

(D) Application of Rates and Charges (Cont'd)

(1) (Cont'd)

(h) Express Connect #

The Express Connect provides a connection to the Telephone Company's Optical Networking wire center(s) via a ring topology consisting of three nodes, one of which must be a Telephone Company wire center. When two of the nodes are customer designated locations, both must be served by the same serving wire center and only one customer location can be without an Express Connect CDL Node. The Express Connect is provided at a bandwidth of OC3, OC12 or OC48 and may be ordered under a one (1) year, three (3) year, five (5) year or seven (7) year Term Payment Plan (TPP).

The Express Connect has three rate elements, a "First System" with optional "Additional System(s) and Additional Express Nodes." The customer may order up to three "Additional Systems" of OC3, OC12 or OC48 bandwidth not to exceed OC12, OC48 or OC192 bandwidth capacity, respectively. Rider charges for Express Connect are included in its monthly rate.

The customer may subscribe to Custom Connect Shared Transport, Custom Connect Dedicated Transport or Banded Optical Transport with Express Connect.

The customer may also subscribe to Telephone Company provided banded SONET transport with Express Connect, provided that such connections are technically and operationally feasible, as determined by the Telephone Company.

- # Effective August 15, 2009, orders for new Express Connect First Systems, Additional CDL Nodes, and/or Additional CO Nodes are no longer permitted. The Telephone Company will continue to provide Express Connect pursuant to this Section 20 on any existing Express Connect that is in-service as of August 15, 2009, or any order for Express Connect that is placed with the Telephone Company prior to August 15, 2009, (collectively, Existing Express Connect). Changes in bandwidth capacity, moves, and/or rearrangements are not permitted.

ACCESS SERVICE

20. OPTICAL NETWORKING (Cont'd)

(D) Application of Rates and Charges (Cont'd)

(1) (Cont'd)

(i) Flex Express Connect #

The Flex Express Connect provides a connection to the Telephone Company's Optical Networking wire center(s) via ring topology with a minimum of four nodes, two of which must be Telephone Company wire centers. When two or more of the nodes are customer designated locations, only one of those nodes may be without electronics. The Flex Express Connect is provided at a bandwidth of OC3, OC12 or OC48.

Flex Express Connect is comprised of four rate elements, a "First System" with optional "Additional System(s)", Additional Flex Nodes and Flex Express Transport. The customer may order up to three "Additional System(s) of OC3, OC12 or OC48 bandwidth not to exceed OC12, OC48 or OC192 bandwidth capacity, respectively.

Flex Express Transport is applied to the entire circumference of the service and is measured from the serving wire center of the customer designated location(s) and the CO Nodes. Flex Express Transport is ordered with the "First System" and each "Additional System" Flex Express Connect in OC3, OC12 or OC48 bandwidth not to exceed OC12, OC48 or OC192 bandwidth capacity, respectively.

Flex Express may be ordered under a one (1) year, three (3) year, five (5) year or seven (7) year Term Payment Plan (TPP). After the initial order for Flex Express Connect, month-to-month rates shall apply for the Additional Flex Nodes. When the TPP of the Flex Express "First System" expires and the customer does not renew the TPP as shown in 20.3(G)(2), the first Flex Express "Additional System" will assume the Flex Express "First System" rates.

- # Effective August 15, 2009, orders for new Flex Express Connect First Systems, Additional CDL Nodes, and/or Additional CO Nodes are no longer permitted. The Telephone Company will continue to provide Flex Express Connect pursuant to this Section 20 on any existing Flex Express Connect that is in-service as of August 15, 2009, or any order for Flex Express Connect that is placed with the Telephone Company prior to August 15, 2009, (collectively, Existing Flex Express Connect). Changes in bandwidth capacity, moves, and/or rearrangements are not permitted.

ACCESS SERVICE

20. OPTICAL NETWORKING (Cont'd)

(D) Application of Rates and Charges (Cont'd)

(1) (Cont'd)

(i) Flex Express Connect # (Cont'd)

In addition to the Flex Express Connect rate elements, Custom Connect Transport (CC Transport), as described in 20(D)(1)(j), is applicable for transport from the serving wire centers of the customer designated locations and CO Nodes. Rider charges for Flex Express Connect are included in its monthly rate.

The customer may subscribe to Banded Optical Transport with Flex Express Connect.

The customer may also subscribe to Telephone Company provided banded SONET transport with Flex Express Connect, provided that such connections are technically and operationally feasible, as determined by the Telephone Company.

Rider charges are included in the monthly rate for Flex Express Connect.

Service availability limited. Refer to # footnote on Page 20-5.

ACCESS SERVICE

20. OPTICAL NETWORKING (Cont'd)

(D) Application of Rates and Charges (Cont'd)

(1) (Cont'd)

(j) Custom Connect #

The Custom Connect provides a connection to the Telephone company's Optical network and an access customer's designated location (CDL). The Custom Connect is comprised of CO Nodes, CDL Links or SONET Premises Nodes, Transport and Riders. Each Custom Connect must consist of a minimum of two customer designated locations, one of which must be a CDL Link.

The Custom Connect may be ordered as switched or special access. The Concatenated/Non-concatenated Custom Connect CDL Link is provided with a two fiber network interface. The Concatenated/Non-concatenated CDL Link may be optionally ordered with a four fiber, 1+1 protected network interface, as Single or Diverse Route.

Custom Connect may connect to Intellilight® Optical Transport Service (IOTS) optical transport channels or may be provided over an IOTS backbone network as set forth in 20.1 following. IOTS combines DWDM and SONET technologies to create a high-speed backbone network.

Custom Connect may also be connected to the following Telephone Company services, provided that such connections are technically and operationally feasible, as determined by the Telephone Company:

- dedicated SONET ring service
- point-to-point SONET service
- DWDM ring service
- SONET entrance facility service
- ethernet private line service

Custom Connect may also be provided over a Telephone Company provided DWDM ring backbone network provided that such configurations are technically and operationally feasible, as determined by the Telephone Company.

Custom Connect Single Route and Diverse Route at OC12c and OC48c may also connect to an advanced data service at designated Telephone Company wire centers.

ACCESS SERVICE

20. OPTICAL NETWORKING (Cont'd)

(D) Application of Rates and Charges (Cont'd)

(1) (Cont'd)

(j) Custom Connect # (Cont'd)

CO Node

The CO Node rate element is applicable for each central office that is equipped with a fiber optic terminal in which the customer requests the ability to add/drop traffic to a CDL. Traffic is dropped from the CO Node via ports (lower speed drops). The CO Node may be ordered when a customer requires OC level multiplexing on the Custom Connect. If the customer wants to drop traffic below a DS3 at the CO Node, the customer must request a minimum DS1 interface and appropriate special access lines from Section 5. The CO Node may also be used when the customer wants to add/drop DS1 or DS3 traffic to a CDL located between the service areas shown under Section 5.2.7(H). The OC192 CO Node's ability to drop traffic below an OCn level is limited to new and in-service terminals technically capable of providing such directly from the ADM. See Rider section, herein, for further details. The appropriate multiplexing and access lines and transport rates from Section 5 will apply in addition to the CO Node and appropriate rider charges. However, multiplexing rates from Section 5 will not apply when the following conditions are met

- (1) The Customer requests to drop a DS3 from a CO Node for the purpose of establishing a DS3 multiplexed facility in its serving wire center; and
- (2) the customer subscribes to and is billed for the CO Node rate element; and
- (3) the customer CO Node is located in the same central office building where the DS3 multiplexed facility is to be located

When the customer CO Node is not located within the wire center serving the CDL, rates including the 3/1 multiplex rates apply as set forth in Section 5 and other Sections of this tariff. These charges are in addition to the appropriate CO Node, rates associated with transport of the DS3 facility to the wire center where the CO Node is located and rider charges applicable under this Section 20.

The CO Node may be ordered at an OC3, OC12, OC48 or OC192 bandwidth capacity.

ACCESS SERVICE

20. OPTICAL NETWORKING (Cont'd)

(D) Application of Rates and Charges (Cont'd)

(1) (Cont'd)

(j) Custom Connect # (Cont'd)

CDL Link

The CDL Link rate element is applicable for each customer designated location in which the customer requests the ability to add/drop traffic. The CDL Link is offered as Single Route, Diverse Route or Ring Route and may be ordered with premise multiplexer provided or with premise fiber meet provided as OC3, OC12, OC48 or OC192 bandwidth capacity. Only one CDL Link per connect may be ordered with premise fiber meet provided. The premise fiber meet will terminate on a fiber cross connect panel at the demarcation point. CDL Link with premise fiber meet is not available for jointly provided meet-point arrangements except where Frontier provides a node within its network to the customer.

If more than two Links or Nodes are ordered on the same order, the CDL Link must be ordered as a Ring Route CDL Link. A Ring Route CDL Link has a minimum of three nodes, one of which must be located in a Telephone | Company wire center. A Custom Connect ordered via a ring topology will be provided with a service guarantee as shown in Section 2.7.1.1. When Custom Connect is configured in a ring topology and is ordered under a meet point billing arrangement in which the Telephone Company acts as an intermediate carrier as set forth in Section 2 preceding, a CO Node is required.

The CDL Link may be ordered as Single Route or Diverse Route with concatenated or non-concatenated optical interface for OC3/OC3c, OC12/OC12c and OC48/OC48c. These CDL Links will terminate on a fiber cross connect panel at the demarcation point. The rider charges are included in the monthly rate for these CDL Links. The CDL Link may also be ordered as 1.25 and 2.5 Gbps Single Route or Diverse Route. This CDL Link cannot ride a higher level facility and can only be ordered CDL to CDL.

When Custom Connect is provided over an IOTS backbone and the transport between the nodes is provided using IOTS optical transport channels, a SONET Premises Node applies in lieu of the CDL Link to each customer designated location of the Custom Connect ring where SONET multiplexing is required.

When Custom Connect is provided over a Telephone Company provided DWDM backbone and the transport between the nodes is provided using DWDM optical transport channels, a SONET Premises Node applies in lieu of the CDL Link to each customer designated location of the Custom Connect ring where SONET multiplexing is required.

ACCESS SERVICE

20. OPTICAL NETWORKING (Cont'd)

(D) Application of Rates and Charges (Cont'd)

(1) (Cont'd)

(j) Custom Connect # (Cont'd)

CDL Link with Optical Cross Connect

The CDL Link with Optical Cross Connect provides the communications path between the Telephone Company provided electronics and a customer's transmission equipment and facilities where the customer is provided EIS as defined in Section 17. This rate element includes the intra-office connection from the Telephone Company fiber optic terminal and the optical jumpers to facilitate the cross connect to the customer's transmission equipment and facilities within the Telephone Company wire center. This rate element allows connectivity to Frontier Dedicated SONET Ring (DSR) or a Telephone Company provided dedicated SONET ring. The CDL Link with Optical Cross Connect will be provided as single route without Telephone Company provided electronics as OC3, OC3c, OC12, OC12c, OC48, OC48c or OC192 as ordered by the customer.

In addition to the rate for the CDL Link with Optical Cross Connect, the appropriate CDL Link rate element is applicable from the customer-designated location to the serving wire center.

Rates for the CDL Link with Optical Cross Connect are as shown in 20(L)(25) will apply in addition to other charges as specified in Section 17.

Network Channel Interfaces

The network channel interface codes define the bit rates that are available. Network Channel interfaces and codes are defined below:

<u>Service</u>	<u>Ports</u>	<u>Codes</u>
OC3, OC3c	2 Fiber	02SOF.D(B&F)
OC3, OC3c	4 Fiber, 1+1 Protection	04SOF.D(B&F)
STM1	2 Fiber	02SOF.D(B&F)
STM1	4 Fiber, 1+1 Protection	04SOF.D(B&F)
OC12, OC12c, STM4	2 Fiber	02SOF.D(B&F)
OC12, OC12c, STM4	4 Fiber, 1+1 Protection	04SOF.D(B&F)
OC12c, OC48c	2 Fiber	02CXF.A(B&C)
OC48, OC48c	2 Fiber	02SOF.D(B&F)
OC48, OC48c	4 Fiber, 1+1 Protection	04SOF.D(B&F)

ACCESS SERVICE

20. OPTICAL NETWORKING (Cont'd)

(D) Application of Rates and Charges (Cont'd)

(1) (Cont'd)

(j) Custom Connect # (Cont'd)

Transport

Transport may be ordered as shared or dedicated. Shared Transport is applicable when the transport between Node and/or Links is ordered at different bandwidth levels. The Dedicated Transport is applicable when transport between the Nodes and/or Links is of the same bandwidth level.

Shared Transport may be ordered in bandwidths of DS1, DS3/STS1, OC3, OC3c, OC12, OC12c, OC48 or OC48c. Dedicated Transport may be ordered in bandwidths of OC3, OC3c, OC12, OC12c, OC48, OC48c or OC192, 1.25 Gbps or 2.5 Gbps. The transport is mileage sensitive and will be calculated based on the V&H coordinates of the wire centers comprising each segment of the connect. The meet point billing mileage calculation is specified in 2.7.3. The customer has the option to subscribe to Banded Optical Transport in place of Custom Connect Shared Transport. DS1 and DS3/STS1 Shared Transport may also be ordered in combination with Telephone Company provided point-to-point SONET service.

The Custom Connect Transport rate element is distance sensitive using airline mileage between serving wire centers and is calculated consistent with that specified in 2.7 preceding. Mileage is rounded up to the next whole mile.

When point-to-point Custom Connect is provided over an Intellilight Optical Transport Service (IOTS) backbone network as set forth in Section 20.1 following, connection between the Custom Connect nodes is provided using an IOTS optical transport channel in lieu of Custom Connect transport. When Custom Connect configured in a ring topology is provided over an IOTS backbone network, connection between the SONET nodes (Custom Connect CO Nodes and/or SONET Premises Nodes) is provided using unprotected IOTS optical transport channels as set forth in Section 20.1 in lieu of Custom Connect transport. Since protection is inherent in the Custom Connect service, protection is not required on the IOTS optical transport channels.

Connection of Custom Connect configured in a ring topology to an IOTS ring is provided over an equal speed, unprotected optical transport channel (e.g., an OC3 Custom Connect node would connect to a 155.52 Mbps unprotected IOTS channel). Each node of a Custom Connect ring must be located at the same customer designated location or central office as its corresponding IOTS node. When point-to-point Custom Connect is provided over a Telephone Company provided DWDM backbone network, connection between the Custom Connect nodes is provided using a DWDM optical transport channel in lieu of Custom Connect transport. When Custom Connect configured in a ring topology is provided over a Telephone Company provided DWDM backbone network, connection between the SONET nodes (Custom Connect CO Nodes and/or SONET Premises Nodes) is provided using unprotected DWDM optical transport channels in lieu of Custom Connect transport. Since protection is inherent in the Custom Connect service, protection is not required on the DWDM optical transport channels.

ACCESS SERVICE

Connection of Custom Connect configured in a ring topology to a Telephone Company provided DWDM ring is provided over an equal speed, unprotected optical transport channel (e.g., an OC3 Custom Connect node would connect to a 155.52 Mbps unprotected DWDM channel). Each node of a Custom Connect ring must be located at the same customer designated location or central office as its corresponding DWDM node. The Shared Transport rate for Custom Connect Transport DS1 and DS3 bandwidth services apply to the transport facilities connected to Optical Custom Connect services.

Rider

The Rider is the customer's service(s) traversing a higher bandwidth level. Riders may be provided at DS1, DS3, OC3, OC3c, OC12, OC12c, OC48, OC48c or STS1 bandwidth levels as required by the customer. DS1, DS3, and STS1 Riders may also be ordered in combination with Telephone Company provided point-to-point SONET service.

The Rider is provided at a flat-rated monthly recurring charge and is applicable per rider circuit order. A Rider is not charged with a CDL Link – Single or Diverse Route – Concatenated/Non-concatenated optical interface. The Rider charges for Express Connect or Flex Express Connect are included in their monthly rates.

Four fiber 1+1 protection consists of two cards in the add/drop multiplexer, one working card and a second, standby card to provide automatic protection from a fault in the working card. The four fiber 1+1 protection is available with all Telephone Company provided add/drop multiplexers and with compatible CPE and applies per CDL. When a Rider is ordered with four fiber 1+1 protection, the protection charge applies in addition to the charge for the Rider. Customers with those interface arrangements on their Riders are grandfathered as of December 28, 2002, and are not subject to the optional feature charge.

Intrastate riders may be transported on the customer's interstate Optical Networking facility. In jointly provided meet-point arrangements, rider charges apply in addition to other applicable charges when Frontier provides any Ocn mux node, whether provided at the customer premise or in the central office.

Acceptable rider speeds allowed by node type are as follows:

NODES	<u>OC3</u>	<u>OC12</u>	<u>OC48</u>	<u>OC192</u>
DS1 Rider	X	X*	X*	X*
DS3 Rider	X	X	X	X*
STS1 Rider	X	X	X	X
OC3/OC3c Rider		X	X	X
OC12/OC12c Rider			X	X
OC48/OC48c Rider				X

* This provision is only available from nodes that are technically capable of providing DS1 and DS3 drops directly from the OCn node terminal. The maximum capacity utilization that can be delivered by a OCn node selected by the customer may be limited by the number and type of riders that are provisioned on the OCn node and are limited by the maximum number of interfaces available to the OCn backplane. Where the OCn terminal is technically capable of supporting lower bandwidth OCn nodes as a sub-multiplexer, Frontier may

provide such at the customer premise and Central Office Node locations at the tariffed CO Node rates on a per sub-multiplexer node deployed.

Frontier Telephone Companies

INTERSTATE SERVICE GUIDE AND PRICELIST NO. 13

Page 20-6.7

ACCESS SERVICE

20. OPTICAL NETWORKING (Cont'd)

(D) Application of Rates and Charges (Cont'd)

(1) (Cont'd)

(j) Custom Connect # (Cont'd)

SONET Premises Node

The SONET Premises Node rate element applies at each CDL at which a SONET node is needed to complete a Custom Connect ring over an IOTS backbone network. The functionality and capabilities of the SONET Premises Node are the same as those specified for the CO Node preceding. The SONET Premises Node will only be provided when Custom Connect is configured in a ring or point to point topology in which the transport between the nodes (CO Node and/or SONET Premises Nodes) is provided using IOTS optical transport channels. IOTS is described in Section 20.1 following. The SONET Premises Node applies in lieu of the Custom Connect CDL Link.

The SONET Premises Node rate element also applies at each CDL at which a SONET node is needed to complete a Custom Connect ring over a Telephone Company provided DWDM backbone network. The SONET Premises Node will only be provided when Custom Connect is configured in a ring or point to point topology in which the transport between the nodes (CO Node and/or SONET Premises Nodes) is provided using DWDM optical transport channels. The SONET Premises Node applies in lieu of the Custom Connect CDL Link.

ACCESS SERVICE

20. OPTICAL NETWORKING (Cont'd)

(D) Application of Rates and Charges (Cont'd)

(2) Optical Network Transport

The transport element provides for the interoffice Optical Networking designated transport between wire centers on Telephone Company defined LANs. Each IC customer Connect must have its own transport. Transport cannot be shared among IC customer Connects.

Banded SONET Transport may be purchased in DS0, DS1, or DS3 Bandwidths.

(a) Reserved for Future Use

(b) Reserved for Future Use

(c) Reserved for Future Use

(d) Reserved for Future Use

(e) Reserved for Future Use

(f) Banded Optical Transport

Banded Optical Transport# provides transport between the serving wire center of the interexchange access customer's location and the access customer's end user premises. Banded Optical Transport may be provided at DS0, DS1, DS3, or STS1 bandwidth levels as required by the customer. When Banded Optical is ordered at a DS0 level, the customer must request a minimum of a DS1 interface at the IC customer wire center and will be charged the appropriate rider (i.e., DS1 or DS3). Banded Optical Transport is provided with a service guarantee as shown in Section 2.7.1.1. For subscription to Banded Optical Transport, the customer must have an accumulative demand requirement, whether provided pursuant to this Section 20 or as Telephone Company provided banded SONET transport, equivalent to an average of nine DS3s, i.e., 5,978 channels, per LATA, per state. The bandwidth will be reviewed annually at a mutually agreed upon date by the customer and the Company. An allowance of minus 2% will be considered as having met the commitment level. Should the bandwidth fall below minus 2%, the customer will have thirty (30) days to meet the bandwidth requirement. If not met, the customer will be notified by the Telephone Company and will be required to convert from Banded Optical Transport to another Optical Network Transport option.

ACCESS SERVICE

20. OPTICAL NETWORKING (Cont'd)

(D) Application of Rates and Charges (Cont'd)

(2) Optical Network Transport (Cont'd)

(f) Banded Optical Transport (Cont'd)

Banded Optical Transport is provided at a flat-rated monthly charge for one (1) year, three (3) year, five (5) year, or seven (7) year contract periods. The contract period for Banded Optical Transport cannot exceed the contract period of the Connect. Banded Optical Transport includes the special access line from the end user serving wire center to the end user premises, for both on-net and off-net, with the exception of jointly provided Banded Optical Transport. Banded Optical Transport will be provisioned at the highest network facility available at the time of the order. The monthly rate will be determined based on the mileage between the serving wire centers of the customer designated locations and is applicable on a per circuit basis. Mileage will be rounded up to the next whole mile except when the CDLs are collocated.

When both customer designated locations are provided by the Telephone Company, wholly provided, the monthly rates as shown in 20(L)(37-46) are applicable. When one of the customer designated locations is provided by another telephone company, or the customer terminates at a multiplexer in a wire center on IOF, jointly provided, the monthly rates as shown in 20(L)(47-52) shall apply. For jointly provided transport with another telephone company, the meet point billing mileage calculation is specified in Section 2.7.3.

(E) Reserved for Future Use

(F) Reserved for Future Use

ACCESS SERVICE

20. OPTICAL NETWORKING (Cont'd)

(G) Rate Regulations

Optical Networking may be ordered under a one (1), three (3), five (5), or seven (7) year Term Payment Plan (TPP). Any TPP for these services is subject to a TPP Termination Liability Charge as specified herein.

When ordered together the TPP applies to Connects, Banded Optical Transport and Additional Nodes.

(1) Changes in Length of a TPP

Prior to the expiration of a TPP period, the customer may elect to convert to a new TPP period of the same or different length, subject to the following conditions:

- No credit will be given for the new period for payments made under the original TPP arrangement.
- NRCs will not be reapplied for existing services.
- If the new TPP period is shorter in length than the time remaining under the existing TPP, the change to the new TPP period constitutes a disconnect of the existing TPP service and termination liability charges will apply.
- The rates for the new period will be the rates currently in effect at the time of the change.
- If the customer subscribes to a new TPP which is greater in length than the initial TPP term and discontinues one or all of the service elements prior to the expiration of the new termination liability period, the termination liability, as set forth below, will apply based on the remainder of the TPP period in effect at the time of the disconnect.

<u>Year in which Service Is Discontinued</u>	<u>Liability Rate</u>
1	100%
2	75%
3	50%
4 or more	25%

ACCESS SERVICE

20. OPTICAL NETWORKING (Cont'd)

(G) Rate Regulations

(1) Renewal Options

Ninety (90) days prior to the expiration of the existing TPP, the customer shall submit in writing to select a new TPP or disconnect service. If no notice is received, the Company will automatically reconnect the customer to a new TPP with the same term life as the previous.

After completion of the initial TPP term and the customer subscribes to a new term that is longer in length the termination liability, as set forth below, will apply based on the remainder of the TPP period in effect at the time of the disconnect.

<u>Year in which Service Is Discontinued</u>	<u>Liability Rate</u>
1	20%
2	15%
3	10%
4 or more	5%

(3) Conversion

When an existing customer purchases Optical Networking, the customer may upgrade their existing special access services to Optical Networking. The upgrade may require physical network changes, as well as changes to existing billing arrangements. Physical changes consist of reterminating existing services not currently utilizing the Optical network.

Termination liability charges will not apply to the customer's existing services provided the Optical Networking TPP term commitment agreement is equal to or longer in length than the time remaining for the existing arrangement.

(4) Reserved for Future Use (C)

ACCESS SERVICE

20. OPTICAL NETWORKING (Cont'd)

(G) Rate Regulations (Cont'd)

(5) Termination Liability

In the event the customer discontinues one or all of the service elements (Connect, Banded Optical Transport, Additional Node) prior to the end of the termination liability period, initial termination liability charges, as set forth below, will apply based on the remainder of the TPP period in effect at the time of the disconnect.

<u>Year in which Service Is Discontinued</u>	<u>Liability Rate</u>
1	40%
2	35%
3	30%
4 or more	25%

(6) Termination Without Liability

For Banded Optical Transport, termination charges will not apply when the customer disconnects a DS0 or DS1 on a circuit by circuit basis provided the required accumulative bandwidth is met as shown in 20(D)(2)(f).

(7) Upgrade to Higher Bandwidth

The Customer who has grown incrementally, may elect to upgrade service to a higher bandwidth during a TPP period to gain economic efficiencies. Termination charges will not apply as long as the upgraded service remains connected at the same point of termination(s), unless the network is being redesigned to gain network efficiency. Nonrecurring charges associated with the new bandwidth upgrade shall apply.

(8) The Customer may elect to change service from a 2-fiber interface to a 4-fiber interface during a TPP. Termination charges will not apply as long as the changed service remains at the same point of termination(s).

ACCESS SERVICE

20. OPTICAL NETWORKING (Cont'd)

(H) Off-Net Wire Center

Off-Net wire center is a wire center not a designated Optical Networking wire center office. The customer may order a DS0, DS1, DS3 or E1 to the Off-Net wire center. Mileage charges will be determined based on airline miles to the nearest on-net wire center at the transport rates shown in Section 5.

Circuits connected to the Off-Net wire center will be billed existing tariffed rates as shown in Section 5.

(I) Shared Use

Shared Use is the provisioning of Switched Access over Optical Networking. Rating as Optical Networking will continue until such time as a portion of the available Optical Networking capacity is used to provide Switched Access service.

For shared use, a special access DS3 interface must be ordered between the IC customer and the IC customer wire center. When switched trunks are ordered, a DS1 switched interface must be ordered for the switched trunks. A DS3 or DS1 interface ordered as Switched Access will be used exclusively for Switched Access.

As individual channels are activated for Switched Access, monthly charges will be adjusted between Switched Access and Optical Networking Access based on the number of channels used for Switched Access and the remaining Optical Networking Access facility.

The total Shared Use for Switched Access charge is equal to the number of channels used for Switched Access divided by 24 for DS1 or 672 for DS3 times the Monthly Switched Access Charges. The monthly Switched Access rates used will be the current rates for Switched Access Entrance Facility, Direct-Trunked Transport Facility, Direct-Trunked Transport Termination and Multiplexer.

(J) Reserved for Future Use

(K) Reserved for Future Use

ACCESS SERVICE

20. OPTICAL NETWORKING (Cont'd)

(L) Rates and Charges

(1) Reserved for Future Use

(2) Reserved for Future Use

(3) Reserved for Future Use

(4) Reserved for Future Use

(5) Reserved for Future Use

(6) Reserved for Future Use

(7) Reserved for Future Use

(8) Express Connect # - First System

	<u>One Year Monthly Rate</u>	<u>Three Year Monthly Rate</u>	<u>Five Year Monthly Rate</u>	<u>Seven Year Monthly Rate</u>
OC3	\$ 7,700.00	\$ 6,800.00	\$ 6,300.00	\$ 6,200.00
OC12	13,000.00	12,100.00	11,400.00	11,300.00
OC48	27,625.00	27,125.00	26,750.00	26,350.00

Express Connect # - Additional System

	<u>One Year Monthly Rate</u>	<u>Three Year Monthly Rate</u>	<u>Five Year Monthly Rate</u>	<u>Seven Year Monthly Rate</u>
OC3	\$1,100.00	\$1,100.00	\$1,100.00	\$1,100.00
OC12	2,400.00	2,330.00	2,100.00	2,100.00
OC48	9,135.00	9,000.00	9,000.00	9,000.00

Service availability limited. Refer to # footnote on Page 20-4.

ACCESS SERVICE

20. OPTICAL NETWORKING (Cont'd)

(L) Rates and Charges (Cont'd)

(9) Flex Express Connect # - First System

	<u>One Year Monthly Rate</u>	<u>Three Year Monthly Rate</u>	<u>Five Year Monthly Rate</u>	<u>Seven Year Monthly Rate</u>
OC3	\$11,500.00	\$10,200.00	\$ 9,550.00	\$ 9,450.00
OC12	18,800.00	17,600.00	16,700.00	16,600.00
OC48	33,425.00	33,100.00	32,700.00	32,700.00

Flex Express Connect # - Additional System

	<u>One Year Monthly Rate</u>	<u>Three Year Monthly Rate</u>	<u>Five Year Monthly Rate</u>	<u>Seven Year Monthly Rate</u>
OC3	\$1,200.00	\$1,200.00	\$1,200.00	\$1,200.00
OC12	2,300.00	2,300.00	2,100.00	2,100.00
OC48	11,316.00	11,316.00	11,316.00	11,316.00

Service availability limited. Refer to # footnote on Page 20-5.

ACCESS SERVICE

20. OPTICAL NETWORKING (Cont'd)

(L) Rates and Charges (Cont'd)

(10) Express and Flex Express Connect # - Additional CDL Node

	<u>Monthly Rate</u>			
OC3	\$ 3,600.00			
OC12	6,000.00			
OC48	12,945.00			
		<u>One Year</u>	<u>Three Year</u>	<u>Five Year</u>
		<u>Monthly Rate</u>	<u>Monthly Rate</u>	<u>Monthly Rate</u>
				<u>Seven Year</u>
				<u>Monthly Rate</u>
OC3	\$ 3,300.00	\$ 3,300.00	\$ 3,300.00	\$ 3,300.00
OC12	5,900.00	5,800.00	5,450.00	5,450.00
OC48	11,945.00	11,945.00	11,945.00	11,945.00

(11) Express and Flex Express Connect # - Additional CO Node

	<u>Monthly Rate</u>			
OC3	\$2,500.00			
OC12	3,500.00			
OC48	9,130.00			
		<u>One Year</u>	<u>Three Year</u>	<u>Five Year</u>
		<u>Monthly Rate</u>	<u>Monthly Rate</u>	<u>Monthly Rate</u>
				<u>Seven Year</u>
				<u>Monthly Rate</u>
OC3	\$2,200.00	\$2,200.00	\$2,200.00	\$2,200.00
OC12	3,425.00	3,350.00	3,100.00	3,100.00
OC48	8,130.00	8,130.00	8,130.00	8,130.00

Service availability limited. Refer to # footnotes on Pages 20-4 and 20-5.

ACCESS SERVICE

20. OPTICAL NETWORKING (Cont'd)

(L) Rates and Charges (Cont'd)

(12) Flex Express # - First System Transport

Monthly Rate

OC3	\$170.00
OC12	240.00

Flex Express # - Additional System Transport

Monthly Rate

OC3	\$ 25.00
OC12	45.00

Express and Flex Express # - First System Transport

Monthly Rate

OC48	\$500.00
------	----------

Express and Flex Express # - Additional System Transport

Monthly Rate

OC48	\$100.00
------	----------

(13) Custom Connect – Shared Transport

Per Mile
Monthly Rate

DS1	\$12.00
DS3/STS1	100.00
OC3/OC3c	210.00
OC12/OC12c	450.00
OC48/OC48c	1125.00

Service availability limited. Refer to # footnotes on Pages 20-4 and 20-5.

ACCESS SERVICE

20. OPTICAL NETWORKING (Cont'd)

(L) Rates and Charges (Cont'd)

(14) Reserved for Future Use

(15) Reserved for Future Use

(16) Reserved for Future Use

(17) Reserved for Future Use

(18) Reserved for Future Use

(19) Reserved for Future Use

(20) Reserved for Future Use

(21) Reserved for Future Use

(22) Reserved for Future Use

(23) Reserved for Future Use

(24) Reserved for Future Use

(25) Reserved for Future Use

(26) Reserved for Future Use

(27) Reserved for Future Use

(28) Reserved for Future Use

(29) Reserved for Future Use

(30) Reserved for Future Use

(31) Reserved for Future Use

(32) Reserved for Future Use

(33) Reserved for Future Use

(34) Reserved for Future Use

(35) Reserved for Future Use

(36) Reserved for Future Use

(37) Reserved for Future Use

ACCESS SERVICE

20. OPTICAL NETWORKING (Cont'd)

(L) Rates and Charges (Cont'd)

(37) Transport - Banded Optical - DS0 (Wholly Provided)

	<u>One Year Monthly Rate</u>	<u>Three Year Monthly Rate</u>
0 miles	\$ 100.00	\$93.00
1 - 10 miles	102.00	95.00
11 - 20 miles	104.00	97.00
21 + miles	106.00	99.00

	<u>Five Year Monthly Rate</u>	<u>Seven Year Monthly Rate</u>
0 miles	\$ 90.00	\$87.00
1 - 10 miles	92.00	89.00
11 - 20 miles	94.00	91.00
21 + miles	96.00	93.00

(38) Transport - Banded Optical - DS1 (Wholly Provided)

	<u>One Year Monthly Rate</u>	<u>Three Year Monthly Rate</u>
0 miles	\$ 205.00	\$191.00
1 - 10 miles	285.00	268.00
11 - 20 miles	305.00	304.00
21 + miles	350.00	312.00

	<u>Five Year Monthly Rate</u>	<u>Seven Year Monthly Rate</u>
0 miles	\$ 185.00	\$173.00
1 - 10 miles	260.00	245.00
11 - 20 miles	295.00	258.00
21 + miles	300.00	281.00

ACCESS SERVICE

20. OPTICAL NETWORKING (Cont'd)

(L) Rates and Charges (Cont'd)

(39) Transport - Banded Optical - DS3 (Wholly Provided)

	<u>One Year Monthly Rate</u>	<u>Three Year Monthly Rate</u>
0 miles	\$1,800.00	\$1,700.00
1 - 10 miles	2,600.00	2,550.00
11 - 20 miles	4,000.00	3,800.00
21 + miles	5,200.00	4,900.00

	<u>Five Year Monthly Rate</u>	<u>Seven Year Monthly Rate</u>
0 miles	\$1,600.00	\$1,500.00
1 - 10 miles	2,350.00	2,200.00
11 - 20 miles	3,500.00	3,200.00
21 + miles	4,600.00	4,300.00

(40) Reserved for Future Use

(41) Reserved for Future Use

(42) Reserved for Future Use

(43) Reserved for Future Use

(44) Transport - Banded Optical - STS1 (Wholly Provided)

	<u>One Year Monthly Rate</u>	<u>Three Year Monthly Rate</u>
0 miles	\$1,800.00	\$1,700.00
1 - 10 miles	2,600.00	2,550.00
11 - 20 miles	4,000.00	3,800.00
21 + miles	5,200.00	4,900.00

	<u>Five Year Monthly Rate</u>	<u>Seven Year Monthly Rate</u>
0 miles	\$ 1,600.00	\$1,500.00
1 - 10 miles	2,350.00	2,200.00
11 - 20 miles	3,500.00	3,200.00
21 + miles	4,600.00	4,300.00

ACCESS SERVICE

20. OPTICAL NETWORKING (Cont'd)

(L) Rates and Charges (Cont'd)

(45) Reserved for Future Use

(46) Reserved for Future Use

(47) Transport - Banded Optical - DS0 (Jointly Provided)

	<u>One Year Monthly Rate</u>	<u>Three Year Monthly Rate</u>
1 - 10 miles	\$ 9.50	\$ 8.50
11 - 20 miles	11.25	10.25
21 + miles	14.25	13.25

	<u>Five Year Monthly Rate</u>	<u>Seven Year Monthly Rate</u>
1 - 10 miles	\$ 8.25	\$ 8.00
11 - 20 miles	10.00	9.75
21 + miles	12.75	12.50

(48) Transport - Banded Optical - DS1 (Jointly Provided)

	<u>One Year Monthly Rate</u>	<u>Three Year Monthly Rate</u>
1 - 10 miles	\$ 78.00	\$ 72.50
11 - 20 miles	110.00	105.00
21 + miles	150.00	143.00

	<u>Five Year Monthly Rate</u>	<u>Seven Year Monthly Rate</u>
1 - 10 miles	\$ 68.00	\$ 64.00
11 - 20 miles	101.00	94.00
21 + miles	135.00	126.00

ACCESS SERVICE

20. OPTICAL NETWORKING (Cont'd)

(L) Rates and Charges (Cont'd)

(49) Transport - Banded Optical - DS3 (Jointly Provided)

	<u>One Year Monthly Rate</u>	<u>Three Year Monthly Rate</u>
1 - 10 miles	\$ 750.00	\$ 675.00
11 - 20 miles	2,200.00	2,025.00
21 + miles	3,700.00	3,400.00
	<u>Five Year Monthly Rate</u>	<u>Seven Year Monthly Rate</u>
1 - 10 miles	\$ 625.00	\$ 575.00
11 - 20 miles	1,920.00	1,815.00
21 + miles	3,100.00	2,900.00

ACCESS SERVICE

20. OPTICAL NETWORKING (Cont'd)

20.1 Reserved for Future Use

20.2 Reserved for Future Use

20.3 Reserved for Future Use

ACCESS SERVICE

20. OPTICAL NETWORKING (Cont'd)

20.4 Dedicated SONET Entrance Facilities

(A) General

Dedicated SONET Entrance Facilities (DSEF) provides high capacity DS3s with enhanced survivability between a Customer Designated Location (CDL) and the Serving Wire Center (SWC) of that CDL. DSEF is provisioned over the Telephone Company's shared SONET network that includes a self-healing ring that passes through the CDL, the SWC of that CDL, and another wire center as determined by the Telephone Company.

(B) DSEF Components

(1) DSEF consists of two basic service components:

- DSEF Terminations
- DSEF Interfaces

(a) DSEF Terminations

DSEF Terminations provide STS1 bandwidth between the CDL and the SWC of that CDL. The DSEF Terminations carry DS3 services and are delivered with enhanced survivability over the Telephone Company's self-healing SONET network. As a result, the Customer is assured continuity of communication for the DS3 service even if there is a fiber facility failure between the CDL and the SWC of that CDL.

(b) DSEF Interfaces

The DSEF Interface defines the engineering characteristics of the service hand-off at the CDL. The Customer must specify an electrical or optical interface for each DSEF Termination.

(i) Electrical Interface

The electrical DSEF Interface defines the type of service that is to be provided over the Telephone Company provided SONET network. The electrical interface type that is available is DS3 (44.736 Mbps).

The electrical DSEF Interface is used for connecting a DS3 service to a DSEF Termination at the CDL.

ACCESS SERVICE

20. OPTICAL NETWORKING (Cont'd)

20.4 Dedicated SONET Entrance Facilities (Cont'd)

(B) DSEF Components (Cont'd)

(1) (Cont'd)

(b) DSEF Interfaces (Cont'd)

(ii) Optical Interface

The optical DSEF Interface defines the optical handoff at the CDL. The optical interface is used for DS3 services connecting to DSEF Terminations and being mapped to an optical interface at OC3, OC12, or OC48 bandwidth. For example, Customer has the option of connecting multiple DS3 services to DSEF Terminations and mapping multiple DS3 services to a single OC3 optical interface.

(2) A network diagram of an DSEF with DS3 electrical interface and OC3 and OC12 optical interfaces is illustrated below:

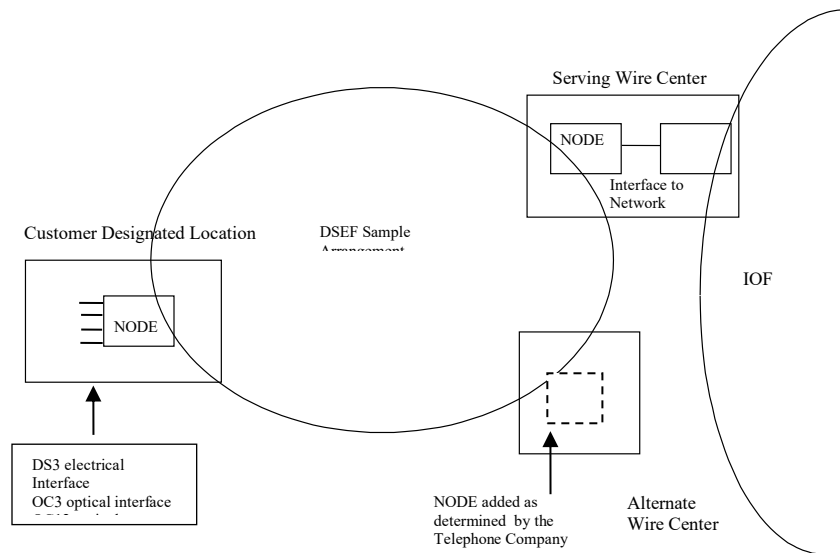

ACCESS SERVICE

20. OPTICAL NETWORKING (Cont'd)

20.4 Dedicated SONET Entrance Facilities (Cont'd)

(B) DSEF Components (Cont'd)

(2) A network diagram of an DSEF with an OC48 optical interfaces is illustrated below:

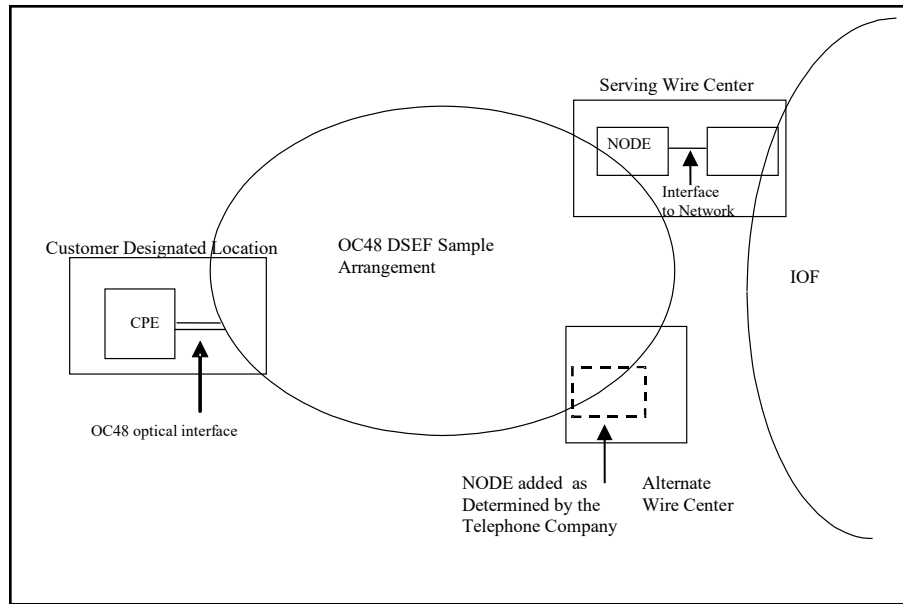

(C) Technical Specifications

Technical specifications for DSEF are set forth in Technical Reference GR-253-CORE, Issue 4.

ACCESS SERVICE

20. OPTICAL NETWORKING (Cont'd)

20.4 Dedicated SONET Entrance Facilities (Cont'd)

(D) Terms and Conditions

(1) Deployment and Availability

- (a) DSEF is provided where SONET facilities and bandwidth are available to provide the requested DSEF Interface. The Telephone Company will work cooperatively with the Customer in determining the availability of such facilities and if service can be provided.
- (b) DSEF is available based on negotiated intervals, as described in Section 5.1.7 preceding.
- (c) Regulations for moves or rearrangements of DS3s are described in Section 7.2.1 preceding.

(2) Service Limitations

If the CDL is located in the same building as the SWC, the diversity between the SWC and the CDL may be limited by the physical paths available to connect the SWC and the CDL, and there may not be fiber diversity routed through an alternate wire center.

(3) Connection to Other Services

- (a) Connection of DS3 Services to DSEF Terminations is provided by the Telephone Company. Interoffice mileage, when applicable, will apply at Special Transport rates, as set forth in Section 7.11.5 preceding, for the appropriate DS3 service being transported over the interoffice facilities

Asynchronous multiplexing of DS1s into a DS3 occurs outside the DSEF and all terms and rates as set forth in Section 7.11 preceding are applicable for such multiplexing.

- (b) DSEF may also be connected to the following Telephone Company provided services, where such connections are technically and operationally feasible, as determined by the Telephone Company.
 - ethernet private line service
 - point-to-point SONET service

ACCESS SERVICE

20. OPTICAL NETWORKING (Cont'd)

20.4 Dedicated SONET Entrance Facilities (Cont'd)

(D) Terms and Conditions (Cont'd)

(4) Space and Power

The Customer will be billed additional charges for any charges levied on the Telephone Company for space and power required to place equipment on the Telephone Company's side of the network interface.

(5) Conversions

Customers who wish to convert existing DS1 and lower bandwidth special access services to a DSEF may do so without termination liability as long as the total capacity of converted services at the CDL does not decrease. A new commitment period commences with the conversion and no credit is given for time-in-service on the new term plan. Applicable nonrecurring charges for installations will apply.

(E) Application of Rates and Charges

(1) Rate Structure

(a) DSEF Terminations

Monthly recurring charges (MRCs) apply for DSEF Terminations. The MRCs are differentiated by the term plan and DSEF Interface selected by the Customer. Nonrecurring charges apply for installations of DSEF Terminations.

Additionally, the MRCs for DSEF Terminations apply on a tapered schedule basis as set forth in (F) following. The rate to be billed for each DSEF Termination is based on the total number of DSEF Terminations that are in-service as of each billing date, on a per CDL basis, and per Billing Account Number (BAN) basis. To determine the total number of DSEF Terminations, the Telephone Company will count all DSEF Terminations and Telephone Company provided SONET entrance facilities provided in connection with a Telephone Company provided point-to-point SONET service or ethernet private line service that terminate at such CDL that are in service and billed under the same BAN.

For example, a Customer purchases five (5) DSEFs that are in-service at three (3) different CDLs, with the 5 DSEFs being billed under two (2) different BANs.

ACCESS SERVICE

20. OPTICAL NETWORKING (Cont'd)

20.4 Dedicated SONET Entrance Facilities (Cont'd)

(E) Application of Rates and Charges (Cont'd)

(1) Rate Structure (Cont'd)

(a) DSEF Terminations (Cont'd)

- (i) The first CDL has two (2) DSEFs, one with fifteen (15) in-service STS1 DSEF Terminations and the other with 5 in-service STS1 DSEF Terminations for a total of twenty (20) STS1 DSEF Terminations. Both DSEFs are under the same BAN. The rate to be billed for each DSEF Termination in the 2 DSEFs at the first CDL is the rate shown for 20 STS1 DSEF Terminations, as set forth in (F) following.
- (ii) The second CDL has two (2) DSEFs, one with twenty (20) in-service STS1 DSEF Terminations and the other with twenty-two (22) in-service STS1 DSEF Terminations, for a total of forty-two (42) STS1 DSEF Terminations. The DSEFs at the second CDL are under separate BANs. The rate to be billed for each DSEF Termination in the first DSEF is the rate shown for 20 STS1 DSEF Terminations. The rate to be billed for each DSEF Termination in the second DSEF is the rate shown for 22 STS1 DSEF Terminations, as set forth in (F) following.
- (iii) The third CDL has one (1) DSEF with nine (9) in-service STS1 DSEF Terminations on the same BAN. The rate to be billed for each DSEF Termination on the DSEF is the rate shown for 9 STS1 DSEF Terminations, as set forth in (F) following.

(b) DSEF Interfaces

MRCs for electrical DSEF Interfaces shall apply as set forth in (F)(2) following. When a customer orders an DSEF with a STS1 termination and an electrical interface, both the MRC for electrical DSEF interface (as set forth in (F)(2) following), and the MRC for STS1 Termination (as set forth in (F)(1) following) shall apply. The MRCs are differentiated by the term plan selected by the Customer. Nonrecurring charges apply for installations of electrical DSEF Interfaces, as set forth in (F)(3) following

ACCESS SERVICE

20. OPTICAL NETWORKING (Cont'd)

20.4 Dedicated SONET Entrance Facilities (Cont'd)

(E) Application of Rates and Charges (Cont'd)

(2) Term Plans

DSEF is available for term plans of three (3) year and five (5) year commitment periods.

DSEF Services may be included in, and concurrently subscribed to, under the National Discount Plan as set forth in Section 22.1 following.

(3) Connection to Other Services

When a Customer connects a DSEF Termination to a DS3 service under a one (1) year commitment period, the DSEF Termination and Interface will be provided under a three (3) year commitment period.

When a Customer connects a DSEF Termination to a DS3 service under a three (3) year or five (5) year commitment period, the DSEF Termination and Interface will be provided under the same length commitment period.

When a Customer connects a DSEF Termination to a DS3 service under a seven (7) year commitment period, the DSEF Termination and Interface will be provided under a five (5) year commitment period.

(4) Expiration of Commitment Period

Upon expiration of the term plan, the Telephone Company will continue to provide DSEF on a month-to-month basis under the same rates, terms and conditions of the current term plan until the earliest to occur of: (a) the Customer cancels service or (b) a valid order for a new term plan is requested by the Customer.

ACCESS SERVICE

20. OPTICAL NETWORKING (Cont'd)

20.4 Dedicated SONET Entrance Facilities (Cont'd)

(E) Application of Rates and Charges (Cont'd)

(5) Termination Liability

(a) A Customer must fulfill the term plan for each DSEF Termination and Interface, or be subject to termination liability for each DSEF Termination and Interface that was not in service for the entire commitment period. If a Customer disconnects service during the first year, termination liability will be calculated at one hundred percent (100%) of the MRCs for the unexpired portion of the first year, and at fifteen percent (15%) for the remainder of the term. If the disconnection takes place after the first year, termination liability is calculated at 15% of the MRCs for the remainder of the term.

(b) Termination liability will not apply to DSEF when:

(i) Reserved for Future Use (C)

(ii) a Customer changes its term plan to a longer commitment period and the CDL does not change.

ACCESS SERVICE

20. OPTICAL NETWORKING (Cont'd)

20.4 Dedicated SONET Entrance Facilities (Cont'd)

(F) Rates and Charges

(1) DSEF Terminations

(Jurisdiction: California and Texas)

(a) Per STS1/51.84 Mbps DSEF Termination
With a DS3 Electrical Interface

	<u>Monthly Rate</u> <u>3 Year Term</u>	<u>Monthly Rate</u> <u>5 Year Term</u>
1	\$2,150.00	\$1,800.00
2	2,100.00	1,600.00
3	1,700.00	1,500.00
4	1,175.00	1,100.00
5	1,000.00	890.00
6	783.00	750.00
7	699.00	640.00
8	636.00	560.00
9	588.00	500.00
10	548.00	440.00
11	516.00	395.00
12	489.00	365.00
13	480.00	362.00
14	477.00	358.00
15	475.00	355.00
16	472.00	353.00
17	470.00	350.00
18	467.00	348.00
19	465.00	345.00
20	462.00	340.00
21	459.00	338.00
22	456.00	336.00
23	454.00	333.00
24	451.00	331.00

ACCESS SERVICE

20. OPTICAL NETWORKING (Cont'd)

20.4 Dedicated SONET Entrance Facilities (Cont'd)

(F) Rates and Charges (Cont'd)

(1) DSEF Terminations (Cont'd)

(Jurisdiction: California and Texas)

(a) Per STS1/51.84 Mbps DSEF Termination
With a DS3 Electrical Interface (Cont'd)

	<u>Monthly Rate</u> <u>3 Year Term</u>	<u>Monthly Rate</u> <u>5 Year Term</u>
25	\$449.00	\$329.00
26	446.00	327.00
27	444.00	325.00
28	441.00	323.00
29	438.00	321.00
30	435.00	319.00
31	433.00	317.00
32	430.00	315.00
33	428.00	312.00
34	425.00	310.00
35	423.00	308.00
36	420.00	306.00
37	407.00	304.00
38	404.00	302.00
39	402.00	298.00
40	399.00	294.00
41	396.00	288.00
42	393.00	283.00
43	391.00	278.00
44	388.00	273.00
45	386.00	267.00
46	383.00	262.00
47	381.00	257.00
48 and up	378.00	252.00

ACCESS SERVICE

20. OPTICAL NETWORKING (Cont'd)

20.4 Dedicated SONET Entrance Facilities (Cont'd)

(F) Rates and Charges (Cont'd)

(1) DSEF Terminations (Cont'd)

(Jurisdiction: California and Texas)

(b) Per STS1/51.84 Mbps DSEF Termination
With an OC3 Optical Interface

	<u>Monthly Rate</u> <u>3 Year Term</u>	<u>Monthly Rate</u> <u>5 Year Term</u>
1	\$2,310.00	\$1,905.00
2	2,260.00	1,705.00
3	1,860.00	1,605.00
4	1,335.00	1,205.00
5	1,175.00	855.00
6	971.00	690.00
7	891.00	633.00
8	831.00	590.00
9	785.00	557.00
10	747.00	530.00
11	717.00	508.00
12	691.00	490.00
13	683.00	488.00
14	680.00	486.00
15	678.00	484.00
16	675.00	482.00
17	673.00	480.00
18	670.00	478.00
19	668.00	476.00
20	665.00	474.00
21	663.00	472.00
22	660.00	470.00
23	658.00	468.00
24	655.00	466.00

ACCESS SERVICE

20. OPTICAL NETWORKING (Cont'd)

20.4 Dedicated SONET Entrance Facilities (Cont'd)

(F) Rates and Charges (Cont'd)

(1) DSEF Terminations (Cont'd)

(Jurisdiction: California and Texas)

(b) Per STS1/51.84 Mbps DSEF Termination
With an OC3 Optical Interface (Cont'd)

	<u>Monthly Rate</u> <u>3 Year Term</u>	<u>Monthly Rate</u> <u>5 Year Term</u>
25	\$653.00	\$464.00
26	650.00	462.00
27	648.00	460.00
28	645.00	458.00
29	643.00	456.00
30	640.00	454.00
31	638.00	452.00
32	635.00	450.00
33	633.00	448.00
34	630.00	446.00
35	628.00	444.00
36	625.00	442.00
37	613.00	440.00
38	610.00	438.00
39	608.00	434.00
40	605.00	430.00
41	603.00	425.00
42	600.00	420.00
43	598.00	415.00
44	595.00	410.00
45	593.00	405.00
46	590.00	400.00
47	588.00	395.00
48 and up	585.00	390.00

ACCESS SERVICE

20. OPTICAL NETWORKING (Cont'd)

20.4 Dedicated SONET Entrance Facilities (Cont'd)

(F) Rates and Charges (Cont'd)

(1) DSEF Terminations (Cont'd)

(Jurisdiction: California and Texas)

(c) Per STS1/51.84 Mbps DSEF Termination
With an OC12 Optical Interface

	<u>Monthly Rate</u> <u>3 Year Term</u>	<u>Monthly Rate</u> <u>5 Year Term</u>
1	\$2,310.00	\$1,905.00
2	2,260.00	1,705.00
3	1,860.00	1,605.00
4	1,335.00	1,205.00
5	1,175.00	970.00
6	896.00	855.00
7	816.00	745.00
8	756.00	665.00
9	710.00	605.00
10	672.00	545.00
11	642.00	500.00
12	616.00	470.00
13	608.00	465.00
14	605.00	455.00
15	603.00	450.00
16	600.00	445.00
17	598.00	440.00
18	595.00	435.00
19	593.00	430.00
20	590.00	424.00
21	588.00	422.00
22	585.00	420.00
23	583.00	418.00
24	580.00	416.00

ACCESS SERVICE

20. OPTICAL NETWORKING (Cont'd)

20.4 Dedicated SONET Entrance Facilities (Cont'd)

(F) Rates and Charges (Cont'd)

(1) DSEF Terminations (Cont'd)

(Jurisdiction: California and Texas)

(c) Per STS1/51.84 Mbps DSEF Termination
With an OC12 Optical Interface (Cont'd)

	<u>Monthly Rate</u> <u>3 Year Term</u>	<u>Monthly Rate</u> <u>5 Year Term</u>
25	\$578.00	\$414.00
26	575.00	412.00
27	573.00	410.00
28	570.00	408.00
29	568.00	406.00
30	565.00	404.00
31	563.00	402.00
32	560.00	400.00
33	558.00	398.00
34	555.00	396.00
35	553.00	394.00
36	550.00	392.00
37	538.00	390.00
38	535.00	388.00
39	533.00	384.00
40	530.00	380.00
41	528.00	375.00
42	525.00	370.00
43	523.00	365.00
44	520.00	360.00
45	518.00	355.00
46	515.00	350.00
47	513.00	345.00
48 and up	510.00	340.00

ACCESS SERVICE

20. OPTICAL NETWORKING (Cont'd)

20.4 Dedicated SONET Entrance Facilities (Cont'd)

(F) Rates and Charges (Cont'd)

(1) DSEF Terminations (Cont'd)

(Jurisdiction: California and Texas)

(d) Per STS1/51.84 Mbps DSEF Termination
With an OC48 Optical Interface

	<u>Monthly Rate</u> <u>3 Year Term</u>	<u>Monthly Rate</u> <u>5 Year Term</u>
1	\$6,288.00	\$4,488.00
2	3,144.00	2,244.00
3	2,096.00	1,496.00
4	1,572.00	1,122.00
5	1,258.00	898.00
6	1,048.00	748.00
7	898.00	641.00
8	786.00	561.00
9	699.00	499.00
10	629.00	449.00
11	572.00	408.00
12	524.00	343.33
13	517.00	342.41
14	515.00	340.58
15	513.00	338.74
16	510.00	337.82
17	509.00	335.99
18	506.00	334.15
19	505.00	333.23
20	502.00	331.40
21	500.00	329.56
22	498.00	327.73
23	496.00	326.81
24	493.00	324.97

ACCESS SERVICE

20. OPTICAL NETWORKING (Cont'd)

20.4 Dedicated SONET Entrance Facilities (Cont'd)

(F) Rates and Charges (Cont'd)

(1) DSEF Terminations (Cont'd)

(Jurisdiction: California and Texas)

(d) Per STS1/51.84 Mbps DSEF Termination
With an OC48 Optical Interface (Cont'd)

	<u>Monthly Rate</u> <u>3 Year Term</u>	<u>Monthly Rate</u> <u>5 Year Term</u>
25	\$492.00	\$323.14
26	489.00	322.22
27	488.00	320.38
28	485.00	318.55
29	483.00	317.63
30	481.00	315.79
31	479.00	313.96
32	476.00	312.12
33	475.00	311.20
34	472.00	309.37
35	471.00	307.53
36	468.00	306.61
37	458.00	304.78
38	455.00	302.94
39	454.00	300.19
40	451.00	296.51
41	449.00	292.84
42	447.00	289.17
43	445.00	285.50
44	442.00	280.91
45	441.00	277.24
46	438.00	273.56
47	437.00	269.89
48 and up	434.00	265.30

ACCESS SERVICE

20. OPTICAL NETWORKING (Cont'd)

20.4 Dedicated SONET Entrance Facilities (Cont'd)

(F) Rates and Charges (Cont'd)

(2) Electrical DSEF Terminations

(a) DS3 Interface Monthly Recurring Charge

(Jurisdiction: California and Texas)

Per interface, per month	<u>3-Year Term</u> \$157.00
--------------------------	--------------------------------

Per interface, per month	<u>5-Year Term</u> \$105.00
--------------------------	--------------------------------

(3) Installation Charges

(a) Per DSEF Termination

(Jurisdiction: California and Texas)

STS1 w/ separate Interface	<u>Nonrecurring Charge</u> \$1.00
----------------------------	--------------------------------------

(b) Per electrical DSEF Interface

(Jurisdiction: California and Texas)

Per electrical DSEF Interface - DS3	<u>3-Year Term</u> <u>Nonrecurring Charge</u> \$1.00
-------------------------------------	--

Per electrical DSEF Interface - DS3	<u>5-Year Term</u> <u>Nonrecurring Charge</u> \$1.00
-------------------------------------	--

ACCESS SERVICE

21. Operating Territories of the Frontier Telephone Companies

21.1 General

The operating territory of Frontier Telephone Companies is comprised of the operating territories of Frontier California Inc. and Frontier Southwest Incorporated.

ACCESS SERVICE

21. Operating Territories of the Frontier Telephone Companies (Cont'd)

21.2 Operating Territory of Frontier California Inc.

The operating territory of Frontier California Inc., defined by the names of rate centers, is comprised of the following locations for California.

(A) Operating Territory of California – (4420)

Adelanto	Colfax	Inyokern
Alderpoint	Corcoran	June Lake
Alpaugh	Covelo	Kernville
	Crowley Lake	Knights Landing
Apple Valley	Cuyama	Lake Isabella
Barstow	Desert Knolls	Lathrop
Benton	Dos Palos	Laytonville
Berrenda Mesa	Dos Palos Wye	Lee Vining
Big Bear City	El Mirage	Leggett
Big Bear Lake	Exeter	Lemon Cove
Big Pine	Farmersville	Lenwood
	Farmington	Linden
Bishop	Fellows	Lone Pine
	Fort Irwin	Lost Hills
Boron	Garberville	Lucerne Valley
Bridgeport	Gilroy	Mad River
Button Willow	Glennville	Mammoth Lakes
California City		Manteca
California Hot Springs	Hayfork	Maricopa
Cantua Creek	Helendale	McFarland
Cazadero	Hesperia	McKittrick
China Lake	Hoopa	Newberry
Clements	Independence	North Edwards

ACCESS SERVICE

21. Operating Territories of the Frontier Telephone Companies (Cont'd)

21.2 Operating Territory of Frontier California Inc. (Cont'd)

(A) Operating Territory of California – (4420) (Cont'd)

Olancha	Taft
Ora Loma	Timber Cove
Orleans	Tivy Valley
	Tranquility
Parkfield	Trona
Phelan	Victorville
Piercy	Weaverville
Pine Creek	Weimar
Randsburg	Weldon
Ridgecrest	Whitethorn
Ripon	Willow Creek
Robbins	Wrightwood
Running Springs	Yermo
San Joaquin	
San Miguel	
Sanger	
Sea Ranch	
Snelling	
South Barstow	
Summit Valley	

ACCESS SERVICE

21. Operating Territories of the Frontier Telephone Companies (Cont'd)

21.3 Operating Territory of Frontier Southwest Incorporated

The operating territory of Frontier Southwest Incorporated, defined by the names of rate centers, is comprised of the following locations for Texas.

(A) Operating Territory of Texas – (2154)

Alba	
Bardwell	Lytton Springs
Batson	Martindale
Bells-Savoy	Maypearl
Bertram	McDade
Big Sandy	Merit
Birthright	Miller Grove
Blue Ridge	Nassau Bay
Boling-New Gulf	Nevada
Brashear	Paige
Briggs	Palmer
Bristol	Pickton
Buchanan Dam	Pine Mills
Burnet	Point
Burton	Poth
Caddo Mills	Quinlan
Cash	Raywood
Celeste	Red Springs
Como	Reno
Coupland	Rice
Dale	Roane
Devers	Saratoga
Dorchester	Shirley
Emhouse	Springtown
Emory	Sutherland Springs
Fentress	Tawakoni
Ferris	Telephone
Floresville	Tom Bean
Gillett	Venus
Hardin	Weaver
Hawkins	Whitehouse
Hull	Whitewright
Josephine	Wilmer
Kusiusko	Windom
Lone Oak	

ACCESS SERVICE

21. Operating Territories of the Frontier Telephone Companies (Cont'd)

21.4 Competitive Counties for Special Access

21.4.1 General

Certain Special Access rates and charges are applied based on whether the End User Channel Termination is served from a "Competitive County." Competitive Counties are defined in Section 2.6, and the wire centers within such counties are listed in Section 10.2 below.

In wire centers within a Competitive County, monthly rates and nonrecurring charges for Special Access rate elements are subject to the "Competitive County Rate" to the extent it is specified. The Special Access rates in this Guide apply only to wire centers in Competitive Counties.

21.4.2 Competitive County Lists

(A) The following wire centers are in Competitive Counties:

State	County	Wire Center
CA	Fresno	CNCKCAXF
CA	Fresno	ORMACAXF
CA	Fresno	SNGRCAXF
CA	Fresno	SNJQCAXF
CA	Fresno	TRNQCAXF
CA	Fresno	TVVYCAXF
CA	Kern	BORNCAFX
CA	Kern	BRMSCAXF
CA	Kern	BTNWCAXF
CA	Kern	CFCYCAXF
CA	Kern	CHLKCAXF
CA	Kern	FLWSCAXF
CA	Kern	GLVLCAXF
CA	Kern	INYKCAXF
CA	Kern	KRVLCAXF
CA	Kern	LKISCAXF
CA	Kern	LSHLCAXF
CA	Kern	MCFACAXF

ACCESS SERVICE

21. Operating Territories of the Frontier Telephone Companies (Cont'd)

21.4 Competitive Counties for Special Access (Cont'd)

21.4.2 Competitive County Lists (Cont'd)

(A) The following wire centers are in Competitive Counties: (Cont'd)

State	County	Wire Center
CA	Kern	MCKTCAXF
CA	Kern	MRCPCAXF
CA	Kern	NEDWCAXF
CA	Kern	RDGCCAXG
CA	Kern	RNBGCAXF
CA	Kern	TAFTCAXF
CA	Kern	WLDNCAXF
CA	Kings	CRCRCAXF
CA	Merced	DSPLCAXF
CA	Merced	SNNGCAXG
CA	Monterey	PRFDCAXF
CA	Placer	CLFXCAXF
CA	Placer	WEMRCAXF
CA	San Bernardino	ADLNCAXF
CA	San Bernardino	APVYCAXF
CA	San Bernardino	BBCYCAXF
CA	San Bernardino	BBLKCAXF
CA	San Bernardino	BRSWCAXH
CA	San Bernardino	BRSWCAXJ
CA	San Bernardino	DSKNCAXF
CA	San Bernardino	ELMGCAXF
CA	San Bernardino	FTIRCAXF
CA	San Bernardino	HSPRCAXF
CA	San Bernardino	LCVYCAXF
CA	San Bernardino	LNWDCAXF
CA	San Bernardino	NWBRCAXF
CA	San Bernardino	PHLNCAXF
CA	San Bernardino	RNSPCAXF
CA	San Bernardino	TRONCAXF
CA	San Bernardino	VTVLCAXA
CA	San Bernardino	WRWDCAXF
CA	San Bernardino	YERMCAFX
CA	San Bernardino	HNDLCAXF
CA	San Bernardino	SMVYCAXF

ACCESS SERVICE

21. Operating Territories of the Frontier Telephone Companies (Cont'd)

21.4 Competitive Counties for Special Access (Cont'd)

21.4.2 Competitive County Lists (Cont'd)

(A) The following wire centers are in Competitive Counties: (Cont'd)

State	County	Wire Center
CA	San Joaquin	CLEMCAXF
CA	San Joaquin	FRTNCAXF
CA	San Joaquin	LNDNCAXF
CA	San Joaquin	LTHPCAXF
CA	San Joaquin	MNTCCAXG
CA	San Joaquin	RIPNCAXF
CA	San Luis Obispo	SNMGCAXF
CA	Santa Barbara	CUYMCAXF
CA	Santa Clara	GLRYCAXF
CA	Sonoma	CZDRCAXG
CA	Sonoma	SERNCAXF
CA	Sonoma	TMCVCAXH
CA	Tulare	ALPGCAXF
CA	Tulare	CHSPCAXF
CA	Tulare	EXTRCAXF
CA	Tulare	LMCVCAXF
CA	Tulare	FRVLCAXF
CA	Yolo	KNLDCAXF
CA	Yolo	RBNSCAXG
TX	Bastrop	MCDDTXXA
TX	Bastrop	PAGETXXA
TX	Burnet	BRTRTXXA
TX	Burnet	BRGSTXXB
TX	Burnet	BURNTXXA
TX	Caldwell	DALETXXA
TX	Caldwell	FNTRTXXA
TX	Caldwell	LYSPTXXA
TX	Caldwell	MRDLTXXA
TX	Collin	BLRGTXXA
TX	Collin	JSPHTXXA
TX	Collin	NEVDTXXA
TX	Dallas	WLMRTXXA
TX	Ellis	BRWLTXXA
TX	Ellis	BRSTTXXA
TX	Ellis	FRRSTXXA

ACCESS SERVICE

21. Operating Territories of the Frontier Telephone Companies (Cont'd)

21.4 Competitive Counties for Special Access (Cont'd)

21.4.2 Competitive County Lists (Cont'd)

(A) The following wire centers are in Competitive Counties: (Cont'd)

State	County	Wire Center
TX	Ellis	MYPRTXXA
TX	Ellis	PLMRTXXA
TX	Ellis	RICETXXA
TX	Harris	NSBYTXXA
TX	Hopkins	BRHTTXXA
TX	Hopkins	BRSHTXXA
TX	Hopkins	COMOTXXA
TX	Hopkins	MLGRTXXA
TX	Hopkins	PKTNTXXA
TX	Hopkins	SHRLTXXA
TX	Hopkins	WEVRTXXA
TX	Hunt	CDMLTXXA
TX	Hunt	CASHTXXA
TX	Hunt	CELSTXXA
TX	Hunt	LNOKTXXA
TX	Hunt	QNLNTXXA
TX	Hunt	TAWKTXXA
TX	Johnson	VENSTXXA
TX	Liberty	DVRSTXXA
TX	Liberty	HRDNTXXA
TX	Liberty	HULLTXXA
TX	Liberty	RYWDTXXA
TX	Rains	PONTTXXA
TX	Smith	RDSPTXXA
TX	Smith	WHHSTXXA
TX	Tarrant	RENPTXXA
TX	Upshur	BGSNTXXA
TX	Williamson	CPLDTXXA
TX	Wilson	FLVLTXXA
TX	Wilson	KSCSTXXA
TX	Wilson	POTHTXXA
TX	Wilson	STSPTXXA
TX	Wood	HWKNTXXA
TX	Wood	PNMLTXXA

ACCESS SERVICE

22. Discount Plans

22.1 National Discount Plan #

The following discount plans are available to all customers who purchase the applicable services and meet the requirements for each such discount plan, as set forth in Section 22.1 following for National Discount Plan.

22.1.1 General

(A) Overview

The National Discount Plan (NDP) is an optional discount plan that allows the NDP Customer to aggregate all of its Qualifying Services on a national basis. The NDP provides discounts on certain rate elements of Qualifying Services. The level of discount received by the NDP Customer corresponds to the NDP Customer's quantities of Qualifying Services, the customer's selection of a Commitment Matrix Option, and the Plan Year.

(B) Specific Terms and References

Unless otherwise defined in this Guide, the following terms are used in this Section 22.1. References to other sections of Section 22.1 are provided for further information on each term.

- (1) Achieved Discount Tier: shall mean the Discount Tier (as determined in the Annual True-Up) that the NDP Customer could have achieved during the Annual True-Up Period.
- (2) ACNA: shall mean Access Customer Name Abbreviation, as such term is generally understood in the Telecommunications Industry to be the name abbreviation for a purchaser of Special Access Services and Facilities for Interstate Access.
- (3) Actual Increase: shall mean a measurement used in calculating the CBB Discount, that measures the difference between (i) the number of Equivalent DS1 CTs or Equivalent DS1 CMs (as applicable) in month one (1) of the Annual True-Up Period; and (ii) the number of Equivalent DS1 CTs or Equivalent DS1 CMs (as applicable) in month twelve (12) of the Annual True-Up Period.
- (4) Anniversary Date: shall mean each twelve (12) month anniversary of the NDP Start Date during the Term.

Effective June 1, 2019, the National Discount Plan (NDP) is no longer permitted. NDP customers subscribed as of June 1, 2019 may continue with their existing subscriptions but will not be eligible to extend, renew, reenroll in, convert to a new NDP period, or in any other way continue their existing plan beyond its currently scheduled expiration. If at any time an existing customer terminates its NDP, the customer may not re-subscribe to the plan. (C)

ACCESS SERVICE

22. Discount Plans (Cont'd)

22.1 National Discount Plan # (Cont'd)

22.1.1 General (Cont'd)

(B) Specific Terms and References (Cont'd)

- (5) Annual True-Up: shall mean the true-up conducted by the Telephone Company following the end of each Plan Year during which the Telephone Company shall measure, among other things, whether the NDP Customer has met and/or exceeded the Commitment Level and the Discount Tier for the Annual True-Up Period, as more specifically described in Section 22.1.7 following. A Final True-Up shall be conducted in accordance with Section 22.1.14(B)(1) following.
- (6) Annual True-Up Period: shall mean the most recent Plan Year that has just been completed for which the Annual True-Up is being conducted.
- (7) Assigned Discount Tier: shall mean the applicable Discount Tier that was in effect during an Annual True-Up Period.
- (8) Average Monthly Rate Per Equivalent DS1 CM: shall mean the rate as calculated in accordance with Section 22.1.7(C)(2) following.
- (9) Average Monthly Rate Per Equivalent DS1 CT: shall mean the rate as calculated in accordance with in Section 22.1.7(C)(1) following.
- (10) Channel Termination(s): shall mean the applicable Special Access Lines (SAL(s)) for Qualifying Services (as used in the Telephone Company's Tariff FCC No. 14 (FCC14)), and the applicable Circuit Terminations for Qualifying Services (as used in this Guide) as follows:
 - (a) Channel Terminations for Special Access DS1 Services are described in Section 5.3.6 of FCC14, and Section 7.11.1 preceding of this Guide; and
 - (b) Channel Terminations for Special Access DS3 Services using electrical and optical interfaces are described in Section 5.3.6 preceding of FCC14 and Section 7.11.1 of this Guide; and
 - (c)
 - (d)
 - (e) Channel Terminations for DSEF Services.

Service availability is limited. See # footnote on Page 22-1.

ACCESS SERVICE

22. Discount Plans (Cont'd)

22.1 National Discount Plan # (Cont'd)

22.1.1 General (Cont'd)

(B) Specific Terms and References (Cont'd)

(11) Channel Mileage: shall mean the applicable Special Transport for Qualifying Services (as used in this FCC 14), and the applicable Circuit Mileage for Qualifying Services (as used in this Guide) as follows.

(a) Channel Mileage for Special Access DS1 Services and Special Access DS3 Services are described in Section 5.3.6 preceding of FCC14, and Section 7.11.1 of this Guide.

(b)

(12) Commitment Buy Up Bonus: shall mean an option available to the NDP Customer which allows the NDP Customer to increase (buy-up) their CT Commitment Level and/or their CM Commitment Level, and receive a discount one or both Commitment Levels, as described in Section 22.1.7(E) following.

(13) CBB Discount: shall mean the Commitment Buy-Up Bonus Discount as described in Section 22.1.7(E) following.

(14) Commitment Level: shall mean the CM Commitment Level (i.e., the total number of Equivalent DS1 CMs) and/or the CT Commitment Level (i.e., the total number of Equivalent DS1 CTs) that the NDP Customer must commit to the NDP, as described further in Section 22.1.4 following. If the NDP Customer has Channel Terminations and Channel Mileage, then the NDP Customer must establish a separate Commitment Level for Channel Terminations (CT Commitment Level) and a separate Commitment Level for Channel Mileage (CM Commitment Level).

(15) Commitment Matrix: shall mean the Premier Commitment Matrix, the Standard Commitment Matrix or the Deluxe Commitment Matrix, as each is described in Section 22.1.4(C) following.

Service availability is limited. See # footnote on Page 22-1.

ACCESS SERVICE

22. Discount Plans (Cont'd)

22.1 National Discount Plan # (Cont'd)

22.1.1 General (Cont'd)

(B) Specific Terms and References (Cont'd)

- (16) Discount Tier: shall mean the tier in each of the tables set forth in Section 22.1.4(B) following into which the NDP Customer falls based on the actual quantities of Equivalent DS1 CTs or Equivalent DS1 CMs, as applicable.
- (17) Discount Tier Adjustment: shall mean the adjustment (if applicable) to a higher or a lower Discount Tier based on the difference (if any) between the NDP Customer's Achieved Discount Tier and Assigned Discount Tier, as calculated during the Annual True-Up Period. See Section 22.1.7(D) following for further explanation.
- (18) Discounted Rate Elements: shall mean those rate elements of the Qualifying Services that receive a discount under the NDP. A listing of the Discounted Rate Elements is set forth in Section 22.1.5(A) following.
- (19) Equivalent DS1 CTs: shall mean the total number of equivalent DS1 Channel Terminations for Qualifying Services as determined in accordance with Section 22.1.4 following.
- (20) Equivalent DS1 CMs: shall mean the total number of equivalent DS1 Channel Miles for Qualifying Services as determined in accordance with Section 22.1.4 following.
- (21)
- (22) DSEF Services: shall mean, as applicable, either (a) Special Access Dedicated SONET Entrance Facilities STS1 terminations (excluding interface options) as described in Section 20.4 preceding of FCC14, and Section 20.4 of this Guide; or (b) Telephone Company provided SONET entrance facility STS1 terminations (excluding interface options) provided by the Telephone Company where such service is technically and operationally feasible, as determined by the Telephone Company.
- (23) Initial Term: shall mean the five (5) year initial term of the NDP.

Service availability is limited. See # footnote on Page 22-1.

ACCESS SERVICE

22. Discount Plans (Cont'd)

22.1 National Discount Plan # (Cont'd)

22.1.1 General (Cont'd)

(B) Specific Terms and References (Cont'd)

- (24) Monthly Average Count of Equivalent DS1 CMs: shall mean the average number of Equivalent DS1 CMs that were in-service during each month of the Annual True-Up Period, as calculated in accordance with Section 22.1.7(B)(1) following.
- (25) Monthly Average Count of Equivalent DS1 CTs: shall mean the average number of Equivalent DS1 CTs that were in-service during each month of the Annual True-Up Period, as calculated in accordance with Section 22.1.7(B)(1) following.
- (26) Monthly Charges: shall mean the dollar amount of monthly recurring charges billed by the Telephone Company for Discounted Rate Elements.
- (27) Monthly Shortage: shall mean the difference between (i) the Monthly Average Count of Equivalent DS1 CTs or Monthly Average Count of Equivalent DS1 CMs, as applicable; and (ii) the NDP Customer's CT Commitment Level or CM Commitment Level, respectively.
- (28) NDP Customer: shall mean collectively the subscribing customer (as defined in Section 2.6 preceding) and all Persons that are included in the same NDP.
- (29) NDP Start Date: shall mean the start date of the NDP Customer's NDP as described in Section 22.1.2(A)(1) following.
- (30) Non-Discounted Billed Amounts: shall mean the Monthly Charges for the Discounted Rate Elements that would have been billed if the discount percentages of the NDP had not been applied, as calculated in accordance with Section 22.1.7(D) following.

Service availability is limited. See # footnote on Page 22-1.

ACCESS SERVICE

22. Discount Plans (Cont'd)

22.1 National Discount Plan # (Cont'd)

22.1.1 General (Cont'd)

(B) Specific Terms and References (Cont'd)

- (31) Person: shall mean any individual, corporation, association, partnership (general or limited), joint venture, trust, estate, limited liability company, or other legal entity or organization.
- (32) Plan Year: shall mean each 12 month period during the Term of the NDP commencing on the NDP Start Date and each Anniversary Date thereafter, as applicable.
- (33) Qualifying Services: shall mean Special Access DS1 Services, Special Access DS3 Services, and DSEF Services provided by the Telephone Company to the NDP Customer as more specifically described in Section 22.1.3 following of this Guide, and Section 23.1.3 of FCC14.
- (34) Renewal Term: shall mean any renewed 5-year period of the NDP.
- (35) Sale Adjustment: shall mean an adjusted amount of Equivalent DS1 CTs and an adjusted amount of Equivalent DS1 CMs which are no longer provided to the NDP Customer as a result of a Telephone Company Sale.
- (36) Shortfall Penalty: shall mean a penalty assessed against the NDP Customer when it fails to meet its CT Commitment Level and/or CM Commitment Level, as applicable, as further described in Section 22.1.7(C) following.
- (37) Special Access DS3 Service: shall mean Special Access DS3 High Capacity Service as described in Section 7.11 of this Guide, and Special Access High Capacity Digital DS3 Service as described in Section 5.3.6(E) of FCC14.

Service availability is limited. See # footnote on Page 22-1.

ACCESS SERVICE

22. Discount Plans (Cont'd)

22.1 National Discount Plan # (Cont'd)

22.1.1 General (Cont'd)

(B) Specific Terms and References (Cont'd)

- (38) Special Access DS1 Service: shall mean Special Access DS1 High Capacity Service as described in Section 7.11 of this Guide and Special Access High Capacity Digital DS1 Service as described in Section 5.3.6(A) of FCC14.
- (39) Subscription Date: shall mean the date that the Telephone Company receives an executed and completed subscription document from the NDP Customer as described in Section 22.1.2(A) following.
- (40) Telephone Company Sale: shall mean the sale or other divestiture of an operating territory or a portion of an operating territory of a Telephone Company, whereby the Telephone Company no longer provides Qualifying Services in such operating territory or portion of an operating territory.
- (41) Term: shall mean the Initial Term, and any Renewal Term(s).
- (42) Upgrade or Upgraded: shall mean the replacement of (i) a Qualifying Service with a Qualifying Service of a higher bandwidth or capacity (e.g., replacement of a Special Access DS3 Service with an IEF Service); or (ii) a Qualifying Service with another Telephone Company provided service of a higher bandwidth or capacity that is not a Qualifying Service (e.g., replacement of a Special Access DS3 Service with an Ethernet Service of a higher bandwidth).
- (43) Upgrade Adjustment: shall mean an adjusted number of Equivalent DS1 CTs and an adjusted number of Equivalent DS1 CMs that were Upgraded by the NDP Customer during the Annual True-Up Period.

Service availability is limited. See # footnote on Page 22-1.

ACCESS SERVICE

22. Discount Plans (Cont'd)

22.1 National Discount Plan # (Cont'd)

22.1.1 General (Cont'd)

(C) ACNAs Subscribing to NDP

When an ACNA is included in the NDP, the subscribing customer must specify which Qualifying Services within that ACNA are to be included in the NDP.

- (1) At the time of subscription to NDP, the subscribing customer must include all of its ACNAs in the NDP. The NDP Customer also has the option to include the ACNA(s) of one or more Person(s) in its NDP (subject to written authorization from the NDP Customer and the applicable Person(s)). In this case, the NDP Customer's NDP shall include (1) all of the subscribing customer's ACNA(s); and (ii) all of the ACNA(s) of the Person(s) that the subscribing customer wishes to include in its NDP (subject to written authorization from the NDP Customer and the applicable Person(s)).
- (2) If, subsequent to the NDP Start Date, the NDP Customer wishes to add one or more ACNA(s) to its NDP for one of the following reasons, then all such ACNA(s) of the NDP Customer or Person(s), as applicable, shall be added to the NDP Customer's NDP at the time of the next Annual True-Up, in accordance with the terms set forth in Section 22.1.11 following.
 - (a) NDP Customer (at its option) wishes to include one or more Person(s) into its NDP that are not currently included in the NDP Customer's NDP (subject to written authorization from the NDP Customer and the applicable Person(s)); or
 - (b) NDP Customer or one of the Person(s) who is currently included in the NDP has acquired one or more new ACNA(s); or
 - (c) NDP Customer has acquired one or more ACNA(s) through merger, acquisition, or other transaction that are not currently included in the NDP Customer's NDP.
- (3) No later than thirty calendar (30) days prior to each Anniversary Date, the NDP Customer must provide written notice to the Telephone Company indicating its intent to add such ACNA(s) to the NDP, and setting forth the affected ACNA(s) and the name of the Person (if applicable) who owns such ACNA(s).

Service availability is limited. See # footnote on Page 22-1.

ACCESS SERVICE

22. Discount Plans (Cont'd)

22.1 National Discount Plan # (Cont'd)

22.1.1 General (Cont'd)

(C) ACNAs Subscribing to NDP

- (4) Once an ACNA is included in the NDP, it cannot concurrently be included in any other NDP. Combination or addition of ACNAs are further described in Section 22.1.11 following.
- (5) For example, assume that a customer who has only one ACNA (ABC) subscribes to the NDP. Assume further that such NDP Customer has five (5) affiliates, but only wishes to include three (3) affiliates in its NDP as of the NDP Start Date. Assume also that each of the three (3) included affiliates each have one ACNA respectively (ACNAs LLL, MMM, and NNN, respectively). In this case, a single NDP will be established for the NDP Customer that includes the following ACNAs: ABC, LLL, MMM, and NNN. Assume further that during Plan Year 2, the NDP Customer decides to include its remaining two (2) affiliates in its NDP. Then, in accordance with this Section 22.1.1 and Section 22.1.11 following, the NDP Customer will include all of the ACNAs of such affiliates into the NDP.

Service availability is limited. See # footnote on Page 22-1.

ACCESS SERVICE

22. Discount Plans (Cont'd)

22.1 National Discount Plan # (Cont'd)

22.1.1 General (Cont'd)

(D) Subscription to Other Tariff Arrangements

- (1) At any time during the Term of the NDP, the NDP Customer may not simultaneously subscribe the same Qualifying Services to the NDP and to other existing or new tariff arrangements (including a contract tariff option as set forth in FCC14), an individual case basis arrangement, specialized service arrangement (or the like), or other discount plan, such as DS1 Term Pricing Plans (as set forth in Section 7 preceding) under this Guide.

Service availability is limited. See # footnote on Page 22-1.

ACCESS SERVICE

22. Discount Plans (Cont'd)

22.1 National Discount Plan # (Cont'd)

22.1.2 Subscription

(A) Subscription Requirements

The NDP Customer's request for subscription to the NDP must be in writing, must be signed by an authorized representative of the NDP Customer, and must be in a manner prescribed by the Telephone Company. In addition, the written request must include all of the following:

(1) NDP Start Date

Notwithstanding a different Subscription Date, the NDP shall start on one of the following dates as determined below:

- (a) If the NDP Customer's Subscription Date to NDP is on or before the fifteenth (15th) calendar day of a month, the NDP Start Date shall be the first (1st) calendar day of the month following the Subscription Date. Application of discounts under the NDP shall begin with the first calendar day in the month following the Subscription Date. For example, assume the NDP Customer's Subscription Date to NDP is July 6th. Then, the NDP Start Date is August 1 and discounts under the NDP shall begin on August 1st.
- (b) If the NDP Customer's Subscription Date to NDP is after the 15th calendar day of a month, the NDP Start Date shall be the 1st calendar day of the second calendar month following the Subscription Date. Application of discounts under the NDP shall begin with the first calendar day in the second month following the Subscription Date. For example, assume the NDP Customer's Subscription Date to NDP is July 17th. Then, the NDP Start Date is September 1st and discounts under the NDP shall begin on September 1st.

Service availability is limited. See # footnote on Page 22-1.

ACCESS SERVICE

22. Discount Plans (Cont'd)

22.1 National Discount Plan # (Cont'd)

22.1.2 Subscription (Cont'd)

(A) Subscription Requirements (Cont'd)

(2) Actual Quantities of Channel Terminations and Channel Mileage for Qualifying Services

The Telephone Company shall calculate the actual quantities of Channel Terminations and Channel Mileage during the month prior to the Subscription Date, based on the Qualifying Services the Customer chooses to include in the NDP. In accordance with Section 23.1.4 following, the Telephone Company shall derive the Equivalent DS1 CTs and the Equivalent DS1 CMs from the actual in-plan quantities of Channel Terminations and Channel Mileage.

(3) Discount Tier

Based on the Equivalent DS1 CTs and Equivalent DS1 CMs determined in (2) above, the Telephone Company will determine the Discount Tier that the NDP Customer falls into in each of the applicable tables set forth in Section 22.1.4(B) following.

(4) Commitment Matrix and Commitment Levels

The NDP Customer must specify a Commitment Level by selecting from one of the following three (3) Commitment Matrix options: (1) Premier Commitment Matrix, as described in Section 22.1.4(C)(1) following; and (2) Standard Commitment Matrix, as described in Section 22.1.4(C)(2) following; and (3) Deluxe Commitment Matrix, as described in 22.1.4(C)(3) following. The NDP Customer's choice of the Commitment Matrix determines (a) the number of Equivalent DS1 CTs and/or Equivalent DS1 CMs that the NDP Customer must commit to the NDP; and (b) the discount on Discounted Rate Elements provided under the NDP.

Service availability is limited. See # footnote on Page 22-1.

ACCESS SERVICE

22. Discount Plans (Cont'd)

22.1 National Discount Plan # (Cont'd)

22.1.3 Qualifying Services (Cont'd)

(A) Inclusion of Qualifying Services in NDP

The Qualifying Services are included in the NDP for purposes of determining the Equivalent DS1 CTs and Equivalent DS1 CMs.

- (1) If the NDP Customer purchases one or more of the Qualifying Services under this Guide, and/or under FCC14, and subscribes to the NDP, the NDP Customer's NDP may include any or all of the Qualifying Services set forth in (B) following that are purchased under such affected tariffs. For each Qualifying Service, the NDP Customer must indicate whether the service is to be included in the NDP.
- (2) The NDP will be administered as a single discount plan across all such tariffs for which a single set of Commitment Levels, Discount Tiers, and Term shall apply.

Service availability is limited. See # footnote on Page 22-1.

ACCESS SERVICE

22. Discount Plans (Cont'd)

22.1 National Discount Plan # (Cont'd)

22.1.3 Qualifying Services (Cont'd)

(B) Qualifying Services

Subject to the terms of Section 22.1.1(D) preceding, the applicable Qualifying Services provided by the Telephone Company to the NDP Customer pursuant to this Guide and FCC14 may be included in the NDP at the time of subscription to NDP and, as applicable, at any time during the Term when the NDP Customer purchases additional quantities of such Qualifying Services.

- (1) Special Access DS1 Service Channel Terminations (see Note 1);
- (2) Special Access DS3 Service Channel Terminations (including Individual System, 3 System, and Unlimited System configurations in this Guide and FCC14, and 12 Capacity System configurations in this Guide) (see Note 2);
- (3) Special Access DS1 Service Channel Mileage (see Notes 1 and 3);
- (4) Special Access DS3 Service Channel Mileage (including Individual System, 3 System, and Unlimited System configurations in FCC14, and Individual System, 3 Capacity System, 12 Capacity System and Unlimited System configurations in this Guide);
- (5) DSEF STS1 Channel Terminations;

Note 1: High Capacity Digital FT1 Facilities in this Guide and FCC14 are not Qualifying Services.

Note 2: Channel Terminations and Channel Mileage for 12 and 24 Group System configurations in this Guide are not Qualifying Services.

Note 3: The MetroLAN Optional Arrangement in this Guide and FCC14 is not a Qualifying Service.

Service availability is limited. See # footnote on Page 22-1.

ACCESS SERVICE

22. Discount Plans (Cont'd)

22.1 National Discount Plan # (Cont'd)

22.1.3 Qualifying Services (Cont'd)

(C) Shared Use Arrangements

For Qualifying Services that are provided as part of a Shared Use Arrangement as set forth in Section 7.2.5 preceding, the Special Access DS3 Service or Special Access DS1 Service will be included in the NDP. The Switched Access Portion for such services of the Shared Use Arrangement will not be included in the NDP or be subject to discounting under the NDP.

(D) Conversion of Qualifying Services

Upon subscription to NDP, all of the NDP Customer may cancel any of its individual circuit-specific term plans for Special Access DS3 Service and Special Access DS1 Service such as DS1 and DS3 term plans as offered under Section 7 preceding, to include all such services in the NDP. Minimum period charges as set forth in Section 7 preceding will not apply to such cancellations. The same Qualifying service may not be included in both NDP and an individual circuit-specific plan.

Additionally, all of the NDP Customer must remove any Qualifying Services it chooses to include in the NDP from its DS1 Term Payment Plan(s) (TPP(s)) offered under Section 7.2.1(G) preceding. If the customer chooses to include all Qualifying Services in a TPP in the NDP, the TPP must be cancelled in order to include all such Special Access DS1 Services in the NDP. Shortfall charges as set forth in Section 7.2.1(G) preceding will not apply to such cancellations. The same Qualifying service may not be included in both NDP and a DS1 TPP.

Further, the NDP Customer may cancel individual circuit-specific term plans and remove Qualifying Services from non-circuit-specific term plans for Special Access DS3 Service and Special Access DS1 Service, such as DS1 Term Volume Plans (TVPs), Eight and Ten Year DS1 Term Volume Plans (ETTVPs), and DS3 Term Volume Plans (DS3 TVPs) as offered under FCC14. The same Qualifying Service may not be included in both NDP and another discount plan.

Service availability is limited. See # footnote on Page 22-1.

ACCESS SERVICE

22. Discount Plans (Cont'd)

22.1 National Discount Plan # (Cont'd)

22.1.3 Qualifying Services (Cont'd)

(E) Addition of Services and Removal of Services

(1) Addition of Services

- (a) The NDP Customer may add Special Access DS3 Service and Special Access DS1 Service at any time during the Term of the NDP. Qualifying Services are added to the NDP for the remainder of the Term (i.e., on a coterminous basis).
- (b) When the NDP Customer adds one or more DSEF Services during the Term of the NDP, the added DSEF Service will be added to the NDP solely for the purpose of calculating the number of Equivalent DS1 CTs and/or the number of Equivalent DS1 CMs used to administer the NDP.

(2) Removal of Services

- (a) When the NDP Customer removes one or more Special Access DS3 Services or Special Access DS1 Services, but not all Special Access DS3 Services and Special Access DS1 Services, from NDP at any time during the Term, no termination liability charge applies.
- (b) When the NDP Customer removes one or more DSEF Services during the Term of the NDP, no termination liability under this Section 22.1 applies. However, the NDP Customer may be subject to termination liability under its applicable term plan for DSEF Service.
- (c) When the NDP Customer removes all Special Access DS3 Services and all Special Access DS1 Services from the NDP (i.e., the NDP Customer cancels its NDP in its entirety), termination liability applies in accordance with Section 22.1.13 following.

Service availability is limited. See # footnote on Page 22-1.

ACCESS SERVICE

22. Discount Plans (Cont'd)

22.1 National Discount Plan # (Cont'd)

22.1.4 Commitment Levels and Discount Tiers

(A) Calculation of Equivalent DS1 CTs and Equivalent DS1 CMs

In order to establish Commitment Levels and Discount Tiers, Equivalent DS1 CTs and Equivalent DS1 CMs must be determined. Based on the actual quantities of Channel Terminations and Channel Mileage included in the NDP, the Telephone Company will calculate the Equivalent DS1 CTs and Equivalent DS1 CMs.

(1) The Equivalent DS1 CTs shall be calculated as follows:

- (Step 1) Determine the actual quantity of Channel Terminations for each Qualifying Service across this Guide and FCC14, as applicable.
- (Step 2) Multiply the actual quantity of Channel Terminations for such Qualifying Service by 100% if the Qualifying Service is Special Access DS1 Service, Special Access DS3 Services, or a DSEF Service
- (Step 3) Using Table 1, below, multiply (a) the applicable number in the column entitled "DS1 CT Multiplier" below; by (b) the number derived in Step 2 above.
- (Step 4) Repeat the process in Steps (1) through (3) for each Qualifying Service.
- (Step 5) Add the product of all of the equivalent Channel Terminations for all of the Qualifying Services derived in Steps (1) through (4) above.

Table 1: Calculation of Equivalent DSI CTs.

<u>Qualifying Service</u>	<u>DS1 CT Multiplier</u>
STS1 level	28
DS3 level	28
DS1 level	1

Service availability is limited. See # footnote on Page 22-1.

ACCESS SERVICE

22. Discount Plans (Cont'd)

22.1 National Discount Plan # (Cont'd)

22.1.4 Commitment Levels and Discount Tiers (Cont'd)

(A) Calculation of Equivalent DS1 CTs and Equivalent DS1 CMs (Cont'd)

(2) The Equivalent DS1 CMs shall be calculated as follows:

- (Step 1) Determine the actual quantity of Channel Mileage for each Qualifying Service across this Guide and FCC14, as applicable.
- (Step 2) Multiply the actual quantity of Channel Mileage for such Qualifying Service by 100% if the Qualifying Service is a Special Access DS1 Service or a Special Access DS3 Service.
- (Step 3) Using Table 2, below, multiply (a) the applicable number in the column entitled "DS1 CM Multiplier" below; by (b) the number derived in Step 2 above.
- (Step 4) Repeat the process in Steps (1) through (3) for each Qualifying Service.
- (Step 5) Add the product of all of the equivalent Channel Mileage for all of the Qualifying Services derived in Steps (1) through (4) above.

Table 2: Equivalent DSI CMs.

<u>Qualifying Service</u>	<u>DS1 CM Multiplier</u>
STS1 level	N/A
DS3 level	28
DS1 level	1

Service availability is limited. See # footnote on Page 22-1.

ACCESS SERVICE

22. Discount Plans (Cont'd)

22.1 National Discount Plan # (Cont'd)

22.1.4 Commitment Levels and Discount Tiers (Cont'd)

(A) Calculation of Equivalent DS1 CTs and Equivalent DS1 CMs (Cont'd)

(2) (Cont'd)

As an example of the above, assume that the NDP Customer has Channel Terminations in the following quantities:

- 200 DSEF STS1 Channel Terminations
- 800 DS3 Channel Terminations
- 3,000 DS1 Channel Terminations

The Equivalent DS1 CTs would be determined as follows:

Channel Termination		DS1 CT Multiplier	=	Equivalent DS1 CTs
200 DSEF STS1s	X	28	=	5,600
800 DS3 CTs	X	28	=	22,400
3000 DS1 CTs	X	1	=	3,000
Total Equivalent DS1 CTs				= 31,000

Further assume that NDP Customer has Channel Mileage in the following quantities:

- 5,000 DS3 Channel Miles
- 75,000 DS1 Channel Miles

The Equivalent DS1 CMs would be determined as follows:

Channel Mileage		DS1 CM Multiplier	=	Equivalent DS1 CMs
5,000 DS3 CMs	X	28	=	140,000
75,000 DS1 CMs	X	1	=	75,000

Service availability is limited. See # footnote on Page 22-1.

ACCESS SERVICE

22. Discount Plans (Cont'd)

22.1 National Discount Plan # (Cont'd)

22.1.4 Commitment Levels and Discount Tiers (Cont'd)

(B) Discount Tier Tables

- (1) The Equivalent DS1 CTs calculated in (A) preceding determine the Discount Tier into which the NDP Customer falls pursuant to the table below:

<u>Equivalent DS1 CTs</u>	<u>Discount Tier</u>
0 – 30,000	A
30,001 – 60,000	B
60,001 - 120,000	C
120,001 - 195,000	D
195,001 - 275,000	E
275,001 - 350,000	F
350,001 - 420,000	G
420,001 - 485,000	H
485,001 - 550,000	I
550,001 or more	J

The Discount Tier determines the discount percentage (as set forth in Section 22.1.5(B) following) to be applied to the Channel Termination and multiplexer Discounted Rate Elements. The Discount Tier determined at the NDP Start Date will remain in effect for each Plan Year of the NDP, unless otherwise adjusted at the Annual True-Up in accordance with Section 22.1.7 following.

Service availability is limited. See # footnote on Page 22-1.

ACCESS SERVICE

22. Discount Plans (Cont'd)

22.1 National Discount Plan # (Cont'd)

22.1.4 Commitment Levels and Discount Tiers (Cont'd)

(B) Discount Tier Tables (Cont'd)

- (2) The Equivalent DS1 CMs calculated in (A) preceding determine the Discount Tier into which the NDP Customer falls pursuant to the table below:

<u>Equivalent DS1 CMs</u>	<u>Discount Tier</u>
0 – 125,000	A
125,001 - 250,000	B
250,001 - 500,000	C
500,001 - 950,000	D
950,001 - 1,550,000	E
1,550,001 - 2,150,000	F
2,150,001 - 2,850,000	G
2,850,001 - 3,450,000	H
3,450,001 - 3,850,000	I
3,850,001 or more	J

The Discount Tier determines the discount percentage (as set forth in Section 22.1.5(B) following) to be applied to the Channel Mileage Discounted Rate Elements. The Discount Tier determined at the NDP Start Date will remain in effect for each Plan Year of the NDP, unless otherwise adjusted at the Annual True-Up in accordance with Section 22.1.7 following.

Service availability is limited. See # footnote on Page 22-1.

ACCESS SERVICE

22. Discount Plans (Cont'd)

22.1 National Discount Plan # (Cont'd)

22.1.4 Commitment Levels and Discount Tiers (Cont'd)

(C) As of the Subscription Date, and at the beginning of any Renewal Term (unless the NDP Customer chooses the Renewal Benefit Option as described in Section 22.1.14(C) following), the NDP Customer must specify a Commitment Matrix by selecting from one of the following three (3) Commitment Matrix options. The NDP Customer's selection of the Commitment Matrix option shall apply to both the CT Commitment Level and to the CM Commitment Level. The NDP Customer may not select a different Commitment Matrix for the CT Commitment Level and a different Commitment Matrix for the CM Commitment Level.

(i) Premier Commitment Matrix, as described in Section (C)(1) following;

(ii) Standard Commitment Matrix, as described in Section (C)(2) following;
and

(iii) Deluxe Commitment Matrix, as described in Section (C)(3) following.

The NDP Customer's choice of the Commitment Matrix determines (a) the number of Equivalent DS1 CMs and/or Equivalent DS1 CTs (as calculated in Section 22.1.4(A) preceding) that the NDP Customer must commit to the NDP; and (b) the discount on Discounted Rate Elements provided under the NDP.

(1) If Premier Commitment Matrix is selected by the NDP Customer, the Telephone Company will establish the CT Commitment Level by multiplying the total number of Equivalent DS1 CTs (as calculated in accordance with Section 22.1.4(A) preceding) by 90%, and the CM Commitment Level by multiplying the total number of Equivalent DS1 CMs (as calculated in accordance with Section 22.1.4(A) preceding) by 90%. If the NDP Customer chooses the Premier Commitment Matrix, the NDP Customer shall receive the applicable discounts set forth in the table in Section 22.1.5(B)(2) following.

Service availability is limited. See # footnote on Page 22-1.

ACCESS SERVICE

22. Discount Plans (Cont'd)

22.1 National Discount Plan # (Cont'd)

22.1.4 Commitment Levels and Discount Tiers (Cont'd)

(C) (Cont'd)

- (2) If Standard Commitment Matrix is selected by the NDP Customer, the Telephone Company will establish the CT Commitment Level by multiplying the total number of Equivalent DS1 CTs (as calculated in accordance with Section 22.1.4(A) preceding) by 85%, and the CM Commitment Level by multiplying the total number of Equivalent DS1 CMs (as calculated in accordance with Section 22.1.4(A) preceding) by 85%. If the NDP Customer chooses the Standard Commitment Matrix, the NDP Customer shall receive the applicable discounts set forth in the table in Section 22.1.5(B)(1) following.
- (3) If Deluxe Commitment Matrix is selected by the NDP Customer, the Telephone Company will establish the CT Commitment Level by multiplying the total number of Equivalent DS1 CTs (as calculated in accordance with Section 22.1.4(A) preceding) by 92%, and the CM Commitment Level by multiplying the total number of Equivalent DS1 CMs (as calculated in accordance with Section 22.1.4(A) preceding) by 92%. If the NDP Customer chooses the Deluxe Commitment Matrix, the NDP Customer shall receive the applicable discounts set forth in the table in Section 22.1.5(B)(3) following.
- (4) Where the calculation in ((1), (2) or (3) preceding results in a fraction of an Equivalent DS1 CT or a fraction of an Equivalent DS1 CM, standard rounding practices shall apply. For example, if there are 9,999.4 Equivalent DS1 CTs, the Telephone Company will round down to 9,999 whole Equivalent DS1 CTs. Similarly, if there are 9,999.5 Equivalent DS1 CTs, the Telephone Company will round up to 10,000 whole Channel Terminations.

Service availability is limited. See # footnote on Page 22-1.

ACCESS SERVICE

22. Discount Plans (Cont'd)

22.1 National Discount Plan # (Cont'd)

22.1.4 Commitment Levels and Discount Tiers (Cont'd)

(C) (Cont'd)

(5) As an example, assume that at the time of subscription to the NDP, the NDP Customer had 31,020.04 Equivalent DS1 CTs, and 215,125.17 Equivalent DS1 CMs. In this case, the NDP Customer would fall into Discount Tier B for Channel Terminations and Discount Tier B for Channel Mileage. Assume further that the NDP Customer chose the Standard Commitment Matrix. Using the table in Section 22.1.5(B)(1) following, in Plan Year 1, the NDP Customer would receive a discount of 33% (i.e., Discount Tier B) on its Special Access DS1 Channel Terminations, and 31% (i.e., Discount Tier B) on its Special Access DS3 Channel Mileage. The Telephone Company would also establish a Commitment Level for Channel Terminations at 26,367 (i.e., 85% multiplied by 31,020.04, with the result rounded down), and a Commitment Level for Channel Mileage at 182,856 (i.e., 85% multiplied by 215,125.17, with the result rounded down).

(6) Changes to the Commitment Matrix

(a) Changes during an Initial Term or a Renewal Term, as applicable.

If the NDP Customer has selected the Premier Commitment Matrix at the beginning of the Initial Term or the Renewal Term, as applicable, the NDP Customer may not change such Commitment Matrix during the Initial Term, or during a Renewal Term, as applicable. If the NDP Customer has selected either the Standard Commitment Matrix or the Deluxe Commitment Matrix at the beginning of the Initial Term or the Renewal Term, as applicable, the NDP Customer may, at its option, change its Commitment Matrix selection to Premier Commitment Matrix at an Annual True-Up as set forth in Section 22.1.7(G) following.

(b) Changes at the end of an Initial Term or a Renewal Term, as applicable.

At the end of the Initial Term or any Renewal Term, as applicable, an NDP Customer that renews its NDP is permitted to pick a different Commitment Matrix for the Renewal Term, so long as such NDP Customer does not also concurrently select the Renewal Benefit Option as set forth in Section 22.1.14(C) following.

Service availability is limited. See # footnote on Page 22-1.

ACCESS SERVICE

22. Discount Plans (Cont'd)

22.1 National Discount Plan # (Cont'd)

22.1.4 Commitment Levels and Discount Tiers (Cont'd)

- (D) Although DSEF Services are used in determining the DS1 Equivalent CTs, rate elements for DSEF Services are not Discounted Rate Elements (i.e., rate elements for such services are not discounted under NDP).
- (E) The initial Commitment Level(s) established as of the NDP Start Date, or upon renewal of the NDP, as applicable, will not change during the Term of the NDP, unless one of the following is in effect:
- (1) If the NDP Customer's count of Equivalent DS1 CTs and/or count of Equivalent DS1 CMs exceeds one hundred sixty percent (160%) of the applicable Commitment Level in effect for the then applicable Annual True-Up Period, as described in Section 22.1.7 following, in which case, the Commitment Level(s) will be adjusted in accordance with Section 22.1.7(B)(2)(b) following; or
 - (2) The NDP Customer is permitted to change its Commitment Matrix as set forth in Section 22.1.4(C)(5) preceding; or
 - (3) The NDP Customer elects to exercise the Commitment Buy-Up Bonus Option as described in Section 22.1.7(E) following; or
 - (4) If the NDP Customer adds or removes an ACNA, then Commitment Levels will be adjusted in accordance with Section 22.1.11 following or Section 22.1.12 following, respectively.

Service availability is limited. See # footnote on Page 22-1.

ACCESS SERVICE

22. Discount Plans (Cont'd)

22.1 National Discount Plan # (Cont'd)

22.1.5 Application of Discount

(A) Discounted Rate Elements

The discounts provided under the NDP shall only be provided on Qualifying Services that the customer chooses to include in the NDP, and only on the following Discounted Rate Elements:

(1)

(2)

Service availability is limited. See # footnote on Page 22-1.

ACCESS SERVICE

22. Discount Plans (Cont'd)

22.1 National Discount Plan # (Cont'd)

22.1.5 Application of Discount

(A) Discounted Rate Elements (Cont'd)

(3) The following Discounted Rate Elements from FCC14 may be included in NDP:

- (a) Special Access High Capacity DS1 (1.544 Mbps) Facilities - SAL rate elements of a Standard Arrangement as specified in Section 5.7.7 preceding, as determined in accordance with Section 19.1 of FCC 14 (see Note 1).
- (b) Special Access High Capacity DS1 (1.544 Mbps) Facilities - Special Transport Facility and Termination rate elements of a Standard Arrangement as specified in Section 5.7.7(A) of FCC 14, as determined in accordance with Section 19.1 of FCC14 (see Notes 1 & 2).
- (c) Special Access High Capacity DS3 (44.736 Mbps) Facilities - SAL rate elements of an Individual System or a 3 System configuration (with or without Telephone Company electronics) as specified in Sections 5.7.10 and 5.7.12 of FCC14, respectively, as determined in accordance with Section 19.1 of FCC14 (see Note 3).
- (d) Special Access High Capacity DS3 (44.736 Mbps) Facilities - Banded Special Transport rate elements of an Individual System, a 3 System, or an Unlimited System configuration as set forth in Section 5.7.14(C) of FCC14.
- (e) Special Access High Capacity DS3 (44.736 Mbps) Facilities - Special Transport Facilities (as set forth in Section 5.7.14(A) of FCC14) and 44.736 Mbps Terminations (as set forth in Section 5.7.14(B) of FCC14) of an Individual System, a 3 Group System or an Unlimited System configuration preceding, as determined in accordance with Section 19.1 of FCC14 (see Note 4).

Note 1: All rate elements of High Capacity Digital FT1 Facilities are not Discounted Rate Elements.

Note 2: All Special Transport rate elements of the MetroLAN Optional Arrangement are not Discounted Rate Elements.

Note 3: All SAL rate elements of an Unlimited System, a 12 Group System, or a 24 Group System are not Discounted Rate Elements.

Note 4: All Special Transport rate elements of a 12 Group System, or a 24 Group System are not Discounted Rate Elements.

Service availability is limited. See # footnote on Page 22-1.

ACCESS SERVICE

22. Discount Plans (Cont'd)

22.1 National Discount Plan # (Cont'd)

22.1.5 Application of Discount

(A) Discounted Rate Elements (Cont'd)

(4) The following Discounted Rate Elements from this Guide may be included in NDP:

- (a) Special Access High Capacity DS1 Service – Circuit Termination rate elements as specified in Section 7.5.11(A) preceding (see Note 1).
- (b) Special Access High Capacity DS1 Service – Fixed and Per Mile Circuit Mileage rate elements as specified in Section 7.11.5(G) preceding (see Notes 1 and 2).
- (c) Special Access High Capacity DS3 Service - Circuit Termination rate elements of an Individual System or a 3 Capacity System configuration (with or without Telephone Company electronics) as specified Section 7.11.5(E) preceding (see Note 3).
- (d) Special Access High Capacity DS3 Service - Banded Circuit Mileage rate elements of an Individual System, an Unlimited System, a 3 Capacity System or a 12 Capacity System configuration as specified in Section 7.11.5(J) preceding.
- (e) Special Access High Capacity DS3 Service - Fixed and Per Mile Circuit Mileage rate elements of an Individual System, an Unlimited System, a 3 Capacity System or a 12 Capacity System configuration as specified in Section 7.11.5(J) preceding.

Note 1: All rate elements of High Capacity Digital FT1 Facilities are not Discounted Rate Elements.

Note 2: All Circuit Mileage rate elements of the MetroLAN Optional Arrangement are not Discounted Rate Elements.

Note 3: All Circuit Termination rate elements of an Unlimited System, a 12 Group System, or a 24 Group System are not Discounted Rate Elements.

Service availability is limited. See # footnote on Page 22-1.

ACCESS SERVICE

22. Discount Plans (Cont'd)

22.1 National Discount Plan # (Cont'd)

22.1.5 Application of Discount (Cont'd)

(B) The percentage of the discount applied to the Discounted Rate Elements set forth below during the Term is determined by the Discount Tier, NDP Customer's selection of the Standard Commitment Matrix, the Premier Commitment Matrix, or the Deluxe Commitment Matrix, and the Plan Year. Discount Tiers may change at an Annual True-Up as set forth in Section 22.1.7 following (e.g., Discount Tier may change at an Annual True-Up).

(1) Standard Commitment Level Discount Percentages & Plan Year

<u>Tier</u>	<u>Year 1</u>	<u>Year 2</u>	<u>Year 3</u>	<u>Year 4</u>	<u>Year 5</u>
Discount Tier A					
DS1 CT	45.50%	45.75%	45.85%	45.95%	46.05%
DS3 CT	14.50%	14.75%	14.85%	14.95%	15.05%
DS1 CM	0.00%	0.00%	0.00%	0.00%	0.00%
DS3 CM	0.00%	0.25%	0.35%	0.45%	0.55%
Discount Tier B					
DS1 CT	47.00%	47.25%	47.35%	47.45%	47.55%
DS3 CT	17.00%	17.25%	17.35%	17.45%	17.55%
DS1 CM	0.00%	0.00%	0.10%	0.20%	0.30%
DS3 CM	0.25%	0.50%	0.60%	0.70%	0.80%
Discount Tier C					
DS1 CT	48.50%	48.75%	48.85%	48.95%	49.05%
DS3 CT	19.00%	19.25%	19.35%	19.45%	19.55%
DS1 CM	0.25%	0.50%	0.60%	0.70%	0.80%
DS3 CM	0.50%	0.75%	0.85%	0.95%	1.05%

Service availability is limited. See # footnote on Page 22-1.

ACCESS SERVICE

22. Discount Plans (Cont'd)

22.1 National Discount Plan # (Cont'd)

22.1.5 Application of Discount (Cont'd)

(B) (Cont'd)

(1) Standard Commitment Level Discount Percentages & Plan Year (Cont'd)

<u>Tier</u>	<u>Year 1</u>	<u>Year 2</u>	<u>Year 3</u>	<u>Year 4</u>	<u>Year 5</u>
Discount Tier D					
DS1 CT	49.50%	49.75%	49.85%	49.95%	50.05%
DS3 CT	21.00%	21.25%	21.35%	21.45%	21.55%
DS1 CM	0.75%	1.00%	1.10%	1.20%	1.30%
DS3 CM	0.75%	1.00%	1.10%	1.20%	1.30%
Discount Tier E					
DS1 CT	50.00%	50.25%	50.35%	50.45%	50.55%
DS3 CT	22.00%	22.25%	22.35%	22.45%	22.55%
DS1 CM	1.00%	1.25%	1.35%	1.45%	1.55%
DS3 CM	1.00%	1.25%	1.35%	1.45%	1.55%
Discount Tier F					
DS1 CT	50.50%	50.75%	50.85%	50.95%	51.05%
DS3 CT	23.00%	23.25%	23.35%	23.45%	23.55%
DS1 CM	1.25%	1.50%	1.60%	1.70%	1.80%
DS3 CM	1.25%	1.50%	1.60%	1.70%	1.80%
Discount Tier G					
DS1 CT	51.00%	51.25%	51.35%	51.45%	51.55%
DS3 CT	23.50%	23.75%	23.85%	23.95%	24.05%
DS1 CM	1.50%	1.75%	1.85%	1.95%	2.05%
DS3 CM	1.50%	1.75%	1.85%	1.95%	2.05%

Service availability is limited. See # footnote on Page 22-1.

ACCESS SERVICE

22. Discount Plans (Cont'd)

22.1 National Discount Plan # (Cont'd)

22.1.5 Application of Discount (Cont'd)

(B) (Cont'd)

(1) Standard Commitment Level Discount Percentages & Plan Year (Cont'd)

<u>Tier</u>	<u>Year 1</u>	<u>Year 2</u>	<u>Year 3</u>	<u>Year 4</u>	<u>Year 5</u>
Discount Tier H					
DS1 CT	51.50%	51.75%	51.85%	51.95%	52.05%
DS3 CT	24.00%	24.25%	24.35%	24.45%	24.55%
DS1 CM	1.75%	2.00%	2.10%	2.20%	2.30%
DS3 CM	1.75%	2.00%	2.10%	2.20%	2.30%
Discount Tier I					
DS1 CT	52.00%	52.25%	52.35%	52.45%	52.55%
DS3 CT	24.50%	24.75%	24.85%	24.95%	25.05%
DS1 CM	2.00%	2.25%	2.35%	2.45%	2.55%
DS3 CM	2.00%	2.25%	2.35%	2.45%	2.55%
Discount Tier J					
DS1 CT	52.50%	52.75%	52.85%	52.95%	53.05%
DS3 CT	25.00%	25.25%	25.35%	25.45%	25.55%
DS1 CM	2.25%	2.50%	2.60%	2.70%	2.80%
DS3 CM	2.25%	2.50%	2.60%	2.70%	2.80%

Service availability is limited. See # footnote on Page 22-1.

ACCESS SERVICE

22. Discount Plans (Cont'd)

22.1 National Discount Plan # (Cont'd)

22.1.5 Application of Discount (Cont'd)

(B) (Cont'd)

(2) Premier Commitment Level Discount Percentages & Plan Year

Tier	Year 1	Year 2	Year 3	Year 4	Year 5
Discount Tier A					
DS1 CT	46.50%	46.75%	46.85%	46.95%	47.05%
DS3 CT	15.50%	15.75%	15.85%	15.95%	16.05%
DS1 CM	0.25%	0.50%	0.60%	0.70%	0.80%
DS3 CM	1.00%	1.25%	1.35%	1.45%	1.55%
Discount Tier B					
DS1 CT	48.00%	48.25%	48.35%	48.45%	48.55%
DS3 CT	18.00%	18.25%	18.35%	18.45%	18.55%
DS1 CM	0.75%	1.00%	1.10%	1.20%	1.30%
DS3 CM	1.25%	1.50%	1.60%	1.70%	1.80%
Discount Tier C					
DS1 CT	49.50%	49.75%	49.85%	49.95%	50.05%
DS3 CT	20.00%	20.25%	20.35%	20.45%	20.55%
DS1 CM	1.25%	1.50%	1.60%	1.70%	1.80%
DS3 CM	1.50%	1.75%	1.85%	1.95%	2.05%

Service availability is limited. See # footnote on Page 22-1.

ACCESS SERVICE

22. Discount Plans (Cont'd)

22.1 National Discount Plan # (Cont'd)

22.1.5 Application of Discount (Cont'd)

(B) (Cont'd)

(2) Premier Commitment Level Discount Percentages & Plan Year (Cont'd)

<u>Tier</u>	<u>Year 1</u>	<u>Year 2</u>	<u>Year 3</u>	<u>Year 4</u>	<u>Year 5</u>
Discount Tier D					
DS1 CT	50.50%	50.75%	50.85%	50.95%	51.05%
DS3 CT	22.00%	22.25%	22.35%	22.45%	22.55%
DS1 CM	1.75%	2.00%	2.10%	2.20%	2.30%
DS3 CM	1.75%	2.00%	2.10%	2.20%	2.30%
Discount Tier E					
DS1 CT	51.00%	51.25%	51.35%	51.45%	51.55%
DS3 CT	23.00%	23.25%	23.35%	23.45%	23.55%
DS1 CM	2.00%	2.25%	2.35%	2.45%	2.55%
DS3 CM	2.00%	2.25%	2.35%	2.45%	2.55%
Discount Tier F					
DS1 CT	51.50%	51.75%	51.85%	51.95%	52.05%
DS3 CT	24.00%	24.25%	24.35%	24.45%	24.55%
DS1 CM	2.25%	2.50%	2.60%	2.70%	2.80%
DS3 CM	2.25%	2.50%	2.60%	2.70%	2.80%
Discount Tier G					
DS1 CT	52.00%	52.25%	52.35%	52.45%	52.55%
DS3 CT	24.50%	24.75%	24.85%	24.95%	25.05%
DS1 CM	2.50%	2.75%	2.85%	2.95%	3.05%
DS3 CM	2.50%	2.75%	2.85%	2.95%	3.05%

Service availability is limited. See # footnote on Page 22-1.

ACCESS SERVICE

22. Discount Plans (Cont'd)

22.1 National Discount Plan # (Cont'd)

22.1.5 Application of Discount (Cont'd)

(B) (Cont'd)

(2) Premier Commitment Level Discount Percentages & Plan Year (Cont'd)

<u>Tier</u>	<u>Year 1</u>	<u>Year 2</u>	<u>Year 3</u>	<u>Year 4</u>	<u>Year 5</u>
Discount Tier H					
DS1 CT	52.50%	52.75%	52.85%	52.95%	53.05%
DS3 CT	25.00%	25.25%	25.35%	25.45%	25.55%
DS1 CM	2.75%	3.00%	3.10%	3.20%	3.30%
DS3 CM	2.75%	3.00%	3.10%	3.20%	3.30%
Discount Tier I					
DS1 CT	53.00%	53.25%	53.35%	53.45%	53.55%
DS3 CT	25.50%	25.75%	25.85%	25.95%	26.05%
DS1 CM	3.00%	3.25%	3.35%	3.45%	3.55%
DS3 CM	3.00%	3.25%	3.35%	3.45%	3.55%
Discount Tier J					
DS1 CT	53.50%	53.75%	53.85%	53.95%	54.05%
DS3 CT	26.00%	26.25%	26.35%	26.45%	26.55%
DS1 CM	3.25%	3.50%	3.60%	3.70%	3.80%
DS3 CM	3.25%	3.50%	3.60%	3.70%	3.80%

Service availability is limited. See # footnote on Page 22-1.

ACCESS SERVICE

22. Discount Plans (Cont'd)

22.1 National Discount Plan # (Cont'd)

22.1.5 Application of Discount (Cont'd)

(B) (Cont'd)

(3) Deluxe Commitment Level Discount Percentages & Plan Year

<u>Tier</u>	<u>Year 1</u>	<u>Year 2</u>	<u>Year 3</u>	<u>Year 4</u>	<u>Year 5</u>
Discount Tier A					
DS1 CT	52.50%	52.75%	52.85%	52.95%	53.05%
DS3 CT	20.00%	20.25%	20.35%	20.45%	20.55%
DS1 CM	3.50%	3.75%	3.85%	3.95%	4.05%
DS3 CM	3.50%	3.75%	3.85%	3.95%	4.05%
Discount Tier B					
DS1 CT	52.50%	52.75%	52.85%	52.95%	53.05%
DS3 CT	20.00%	20.25%	20.35%	20.45%	20.55%
DS1 CM	3.50%	3.75%	3.85%	3.95%	4.05%
DS3 CM	3.50%	3.75%	3.85%	3.95%	4.05%
Discount Tier C					
DS1 CT	52.50%	52.75%	52.85%	52.95%	53.05%
DS3 CT	20.00%	20.25%	20.35%	20.45%	20.55%
DS1 CM	3.50%	3.75%	3.85%	3.95%	4.05%
DS3 CM	3.50%	3.75%	3.85%	3.95%	4.05%

Service availability is limited. See # footnote on Page 22-1.

ACCESS SERVICE

22. Discount Plans (Cont'd)

22.1 National Discount Plan # (Cont'd)

22.1.5 Application of Discount (Cont'd)

(B) (Cont'd)

(3) Deluxe Commitment Level Discount Percentages & Plan Year (Cont'd)

<u>Tier</u>	<u>Year 1</u>	<u>Year 2</u>	<u>Year 3</u>	<u>Year 4</u>	<u>Year 5</u>
Discount Tier D					
DS1 CT	52.50%	52.75%	52.85%	52.95%	53.05%
DS3 CT	20.00%	20.25%	20.35%	20.45%	20.55%
DS1 CM	3.50%	3.75%	3.85%	3.95%	4.05%
DS3 CM	3.50%	3.75%	3.85%	3.95%	4.05%
Discount Tier E					
DS1 CT	52.50%	52.75%	52.85%	52.95%	53.05%
DS3 CT	20.00%	20.25%	20.35%	20.45%	20.55%
DS1 CM	3.50%	3.75%	3.85%	3.95%	4.05%
DS3 CM	3.50%	3.75%	3.85%	3.95%	4.05%
Discount Tier F					
DS1 CT	52.50%	52.75%	52.85%	52.95%	53.05%
DS3 CT	20.00%	20.25%	20.35%	20.45%	20.55%
DS1 CM	3.50%	3.75%	3.85%	3.95%	4.05%
DS3 CM	3.50%	3.75%	3.85%	3.95%	4.05%
Discount Tier G					
DS1 CT	52.50%	52.75%	52.85%	52.95%	53.05%
DS3 CT	20.00%	20.25%	20.35%	20.45%	20.55%
DS1 CM	3.50%	3.75%	3.85%	3.95%	4.05%
DS3 CM	3.50%	3.75%	3.85%	3.95%	4.05%

Service availability is limited. See # footnote on Page 22-1.

ACCESS SERVICE

22. Discount Plans (Cont'd)

22.1 National Discount Plan # (Cont'd)

22.1.5 Application of Discount (Cont'd)

(B) (Cont'd)

(3) Deluxe Commitment Level Discount Percentages & Plan Year (Cont'd)

<u>Tier</u>	<u>Year 1</u>	<u>Year 2</u>	<u>Year 3</u>	<u>Year 4</u>	<u>Year 5</u>
Discount Tier H					
DS1 CT	52.50%	52.75%	52.85%	52.95%	53.05%
DS3 CT	20.00%	20.25%	20.35%	20.45%	20.55%
DS1 CM	3.50%	3.75%	3.85%	3.95%	4.05%
DS3 CM	3.50%	3.75%	3.85%	3.95%	4.05%
Discount Tier I					
DS1 CT	52.50%	52.75%	52.85%	52.95%	53.05%
DS3 CT	20.00%	20.25%	20.35%	20.45%	20.55%
DS1 CM	3.50%	3.75%	3.85%	3.95%	4.05%
DS3 CM	3.50%	3.75%	3.85%	3.95%	4.05%
Discount Tier J					
DS1 CT	52.50%	52.75%	52.85%	52.95%	53.05%
DS3 CT	20.00%	20.25%	20.35%	20.45%	20.55%
DS1 CM	3.50%	3.75%	3.85%	3.95%	4.05%
DS3 CM	3.50%	3.75%	3.85%	3.95%	4.05%

Service availability is limited. See # footnote on Page 22-1.

ACCESS SERVICE

22. Discount Plans (Cont'd)

22.1 National Discount Plan # (Cont'd)

22.1.6 Special Access DS3 Service Channel Mileage Rates

- (A) Special Access DS3 Service Channel Mileage Banded (Circuit Mileage) Rates set forth in Section 7.5.11(J)(2) preceding will apply to Special Access DS3 Services that are provided between two serving wire centers of the same Frontier Telephone Company (i.e., in those instances where service is not provided by more than one exchange telephone company under Section 2.7 preceding).
- (B) Except as set forth in (A) preceding, the Channel Mileage (Circuit Mileage) Rates set forth in Section 7.5.11(J)(1) preceding apply to all other Special Access DS3 Services that are included in the NDP and provided between (i) two (2) Frontier Telephone Companies; or (ii) between a Frontier Telephone Company and another exchange telephone company in accordance with Section 2.4.7 preceding.

Service availability is limited. See # footnote on Page 22-1.

ACCESS SERVICE

22. Discount Plans (Cont'd)

22.1 National Discount Plan # (Cont'd)

22.1.7 Annual True-Up

After each Anniversary Date during the Term, the Telephone Company will conduct an Annual True-Up which shall be used to determine the NDP Customer's compliance with its established Commitment Levels and Discount Tiers for the Annual True-Up Period.

(A) The Annual True-Up shall consist of the following steps which shall be conducted by the Telephone Company in the following order:

- (1) Calculate the Monthly Average Count of Equivalent DS1 CTs and Monthly Average Count of Equivalent DS1 CMs, each as described in Section 22.1.7(B) following; and
- (2) Compare the Monthly Average Count of Equivalent DS1 CMs against the CM Commitment Level, and the Monthly Average Count of Equivalent DS1 CTs against the CT Commitment Level to determine if the NDP Customer (a) has met its applicable Commitment Level(s); or (b) has exceeded its applicable Commitment Level(s), as each is described in (B) following; and
- (3) If the NDP Customer has not met its CT Commitment Level and/or CM Commitment Level, as applicable, then calculate the Shortfall Penalty that is due in accordance with Section 22.1.7(C) following. If the NDP Customer has exceeded its CT Commitment Level or CM Commitment Level, as applicable, then calculate any adjustment to one or both Commitment Level(s) in accordance with Section 22.1.7(B) following; and
- (4) Determine if the Achieved Discount Tier is the same as the Assigned Discount Tier. For an NDP Customer under a Standard Commitment Matrix or Premier Commitment Matrix, if the Assigned Discount Tier is different than the Achieved Discount Tier, then the Telephone Company shall calculate the applicable Discount Tier Adjustment in accordance with Section 22.1.7(D) following. No Discount Tier Adjustment is calculated for an NDP Customer under a Deluxe Commitment Matrix; and

Service availability is limited. See # footnote on Page 22-1.

ACCESS SERVICE

22. Discount Plans (Cont'd)

22.1 National Discount Plan # (Cont'd)

22.1.7 Annual True-Up (Cont'd)

(A) (Cont'd)

- (5) Assuming the NDP Customer is eligible for the Commitment Buy-Up Bonus for either its CT Commitment Level or CM Commitment Level, or both, and the NDP Customer elects to exercise such Commitment Buy-Up Bonus Option, the Telephone Company will calculate the applicable CBB Discount in accordance with Section 22.1.7(E) following. No later than thirty (30) calendar days prior to the Anniversary Date of its NDP, the NDP Customer must notify the Telephone Company in writing of its intent to exercise the Commitment Buy-Up Bonus Option.
- (6) If the NDP Customer added or removed one or more ACNA(s) under Section 22.1.11 or Section 22.1.12 following, respectively, during the Annual True-Up Period, the Telephone Company will adjust the CT Commitment Level and/or CM Commitment Level, as applicable, to reflect Qualifying Services added to or removed from the NDP with such added or removed ACNA(s). No later than thirty (30) calendar days prior to the Anniversary Date of the NDP Customer's NDP, the NDP Customer must notify the Telephone Company in writing of any such changes to its ACNAs.
- (7) Subject to the requirements set forth in Section 22.1.7(F) following, assign the Discount Tiers applicable to the next Plan Year; and
- (8) Assuming the NDP Customer qualifies for a change from the Standard Commitment Matrix to the Deluxe Commitment Matrix or the Premier Commitment Matrix, or for a change from the Deluxe Commitment Matrix to the Premier Commitment Matrix, and the NDP Customer elects to make such change, the Telephone Company will calculate and set the new Commitment Levels associated with the choice of a Deluxe Commitment Matrix or a Premier Commitment Matrix, as applicable and Discount Tiers in accordance with Section 22.1.7(G) following.

Service availability is limited. See # footnote on Page 22-1.

ACCESS SERVICE

22. Discount Plans (Cont'd)

22.1 National Discount Plan # (Cont'd)

22.1.7 Annual True-Up (Cont'd)

(B) Calculation of Monthly Counts and Measuring Monthly Counts Against Commitment Levels

(1) The Telephone Company will calculate the Monthly Average Count of Equivalent DS1 CTs and the Monthly Average Count of Equivalent DS1 CMs for the Qualifying Services purchased under the NDP that were in service for each month of the Annual True-Up Period. The Monthly Average Count of Equivalent DS1 CTs is calculated as follows:

(Step 1) add the actual number of Equivalent DS1 CTs for Qualifying Services purchased under the NDP for each month of the Annual True-Up Period (including any Equivalent DS1 CTs replaced by a Replacing Service using the methodology for a Technology Migration specified in Section 2.10.4 preceding);

(Step 2) add the result from Step 1 preceding to the quantities of Equivalent DS1 CTs determined in (i) and (ii) following:

(i) the Upgrade Adjustment, as calculated in accordance with Section 22.1.7(H) following, for any Qualifying Service(s) that has been Upgraded ; and/or

(ii) the Sale Adjustment, as calculated in accordance with Section 22.1.10 following, for any Qualifying Service(s) which are affected by a Telephone Company Sale;

(Step 3) divide the number derived in Step 2 preceding by 12 months.

A similar calculation is performed by the Telephone Company for calculating the Monthly Average Count of Equivalent DS1 CMs for the Qualifying Services purchased under the NDP by using Equivalent DS1 CMs instead of using Equivalent DS1 CTs.

Service availability is limited. See # footnote on Page 22-1.

ACCESS SERVICE

22. Discount Plans (Cont'd)

22.1 National Discount Plan # (Cont'd)

22.1.7 Annual True-Up (Cont'd)

(B) Calculation of Monthly Counts and Measuring Monthly Counts Against Commitment Levels (Cont'd)

(2) The Telephone Company will compare the Monthly Average Count of Equivalent DS1 CTs against the CT Commitment Level, and the Monthly Average Count of Equivalent DS1 CMs against the CM Commitment Level. If the NDP Customer's Monthly Average Count of Equivalent DS1 CTs is equal to or greater than (subject to certain restrictions as set forth in (a) following) the CT Commitment Level, then the NDP Customer shall be deemed to have met its CT Commitment Level. If the NDP Customer's Monthly Average Count of Equivalent DS1 CMs is equal to or greater than (subject to certain restrictions as set forth in (a) following) the CM Commitment Level, then the NDP Customer shall be deemed to have met its CM Commitment Level.

(a) Where the NDP Customer has met its CT Commitment Level and/or CM Commitment Level, as applicable, but has not exceeded such Commitment Level by more than sixty percent (i.e., the NDP Customer's Monthly Average Count of Equivalent DS1 CTs and/or Monthly Average Count of Equivalent DS1 CMs, as applicable, is less than 160% of the applicable Commitment Level), no action is required. An NDP Customer who elected the Premier Commitment Matrix may be eligible to voluntarily increase (buy up) its CT Commitment Level and/or its CM Commitment Level as specified in Section 22.1.7(E) following.

(b) Where the NDP Customer has exceeded its CT Commitment Level and/or its CM Commitment Level, as applicable, by more than sixty percent (i.e., the NDP Customer's Monthly Average Count of Equivalent DS1 CTs and/or Monthly Average Count of Equivalent DS1 CMs, as applicable, is more than 160% of its applicable Commitment Level), the exceeded Commitment Level(s) will be adjusted as follows:

Service availability is limited. See # footnote on Page 22-1.

ACCESS SERVICE

22. Discount Plans (Cont'd)

22.1 National Discount Plan # (Cont'd)

22.1.7 Annual True-Up (Cont'd)

(B) Calculation of Monthly Counts and Measuring Monthly Counts Against Commitment Levels (Cont'd)

(2) (Cont'd)

(b) (Cont'd)

- (1) Where the NDP Customer elected the Standard Commitment Matrix, and exceeded its CT Commitment Level and/or exceeded its CM Commitment Level by more than 60%, the exceeded Commitment Level(s) will be adjusted to eighty-five percent (85%) of the Monthly Average Count of Equivalent DS1 CTs or Monthly Average Count of Equivalent DS1 CMs, as applicable, for the Annual True-Up Period. Any adjustments to the CT Commitment Level, as described in this Section (B)(2)(b)(1), is made independent of any adjustment to the CM Commitment Level.
- (2) Where the NDP Customer elected the Premier Commitment Matrix and exceeded its CT Commitment Level and/or exceeded its CM Commitment Level by more than 60%, the exceeded Commitment Level(s) will be adjusted to ninety percent (90%) of the Monthly Average Count of Equivalent DS1 CTs or Monthly Average Count of Equivalent DS1 CMs, as applicable, for the Annual True-Up Period. An adjustment to the CT Commitment Level, as described in this Section (B)(2)(b)(2), is made independent of an adjustment to the CM Commitment Level.
- (3) Where the NDP Customer elected the Deluxe Commitment Matrix and exceeded its CT Commitment Level and/or exceeded its CM Commitment Level by more than 60%, the exceeded Commitment Level(s) will be adjusted to ninety-two percent (92%) of the Monthly Average Count of Equivalent DS1 CTs or Monthly Average Count of Equivalent DS1 CMs, as applicable, for the Annual True-Up Period. An adjustment to the CT Commitment Level, as described in this Section (B)(2)(b)(3), is made independent of an adjustment to the CM Commitment Level.

Service availability is limited. See # footnote on Page 22-1.

ACCESS SERVICE

22. Discount Plans (Cont'd)

22.1 National Discount Plan # (Cont'd)

22.1.7 Annual True-Up (Cont'd)

(B) Calculation of Monthly Counts and Measuring Monthly Counts Against Commitment Levels (Cont'd)

(3) Where the NDP Customer has not met its CT Commitment Level and/or has not met its CM Commitment Level, as applicable, a Shortfall Penalty as set forth in Section 22.1.7(C) following applies to each missed Commitment Level.

(C) Shortfall Penalty

A Shortfall Penalty is assessed against (i) the CT Commitment Level when the NDP Customer's Monthly Average Count of Equivalent DS1 CTs is less than the CT Commitment Level; or (ii) the CM Commitment Level is less than the NDP Customer's Monthly Average Count of Equivalent DS1 CMs.

(1) The Shortfall Penalty is calculated as follows:

(Step 1) Calculate the Monthly Average Count of Equivalent DS1 CTs and the Monthly Average Count of Equivalent DS1 CMs during the Annual True-Up Period as set forth in Section 22.1.7(B)(1) preceding.

(Step 2) Determine the Monthly Shortage of Equivalent DS1 CTs and/or the Monthly Shortage of Equivalent DS1 CMs, as applicable.

(a) The NDP Customer's Monthly Shortage of Equivalent DS1 CTs will be determined by subtracting (i) the Monthly Average Count of Equivalent DS1 CTs determined in Step 1; from (ii) the CT Commitment Level.

(b) The NDP Customer's Monthly Shortage of Equivalent DS1 CMs will be determined by subtracting (i) the Monthly Average Count of Equivalent DS1 CMs determined in Step 1; from (ii) the CM Commitment Level.

Service availability is limited. See # footnote on Page 22-1.

ACCESS SERVICE

22. Discount Plans (Cont'd)

22.1 National Discount Plan # (Cont'd)

22.1.7 Annual True-Up (Cont'd)

(C) Shortfall Penalty (Cont'd)

(1) (Cont'd)

(Step 3) Calculate the Lowest Monthly Rate per Equivalent DS1 CT and/or the Lowest Monthly Rate per Equivalent DS1 CM, as applicable.

- (a) The Lowest Monthly Rate per Equivalent DS1 CT is calculated by (i) finding the lowest DS1 CT rate for a Discounted Rate Element; and (ii) finding the lowest average DS3 CT rate for a Discounted Rate Element, where the average DS3 CT rate for a 3 Capacity System is the sum of the rate for the First System plus twice the rate for an additional system, divided by 3; and (iii) dividing the result in (ii) preceding by 28; and (iv) using the lower rate produced by (i) or (iii); and (v) applying the appropriate discount percentage.
- (b) The Lowest Monthly Rate per Equivalent DS1 CM is calculated by (i) finding the lowest DS1 rate per mile for a Discounted Rate element, and (ii) finding the lowest average DS3 CM rate for a Discounted Rate Element, where the average rate for banded mileage is the rate divided by the midpoint of the band or by the lowest distance of a band with no upper limit; and (iii) dividing the result in (ii) preceding by 28; and (iv) using the lower rate produced by (i) or (iii); and (v) applying the appropriate discount percentage.

Service availability is limited. See # footnote on Page 22-1.

Material previously appearing on this page now appears on Page 22-45.1

ACCESS SERVICE

22. Discount Plans (Cont'd)

22.1 National Discount Plan # (Cont'd)

22.1.7 Annual True-Up (Cont'd)

(C) Shortfall Penalty (Cont'd)

(1) (Cont'd)

(Step 4) Calculate the Shortfall Penalty for the CT Commitment Level and/or the CM Commitment Level, as applicable.

- (a) The Telephone Company will calculate the Shortfall Penalty for the CT Commitment Level by multiplying (i) the Monthly Shortage determined in Step 2; by (ii) the Lowest Monthly Rate per Equivalent DS1 CT calculated in Step 3; and by (iii) twelve (12) months.
- (b) The Telephone Company will calculate the Shortfall Penalty for the CM Commitment Level by multiplying (i) the Monthly Shortage determined in Step 2; by (ii) the Lowest Monthly Rate per Equivalent DS1 CM calculated in Step 3; and by (iii) twelve (12) months.

Service availability is limited. See # footnote on Page 22-1.

(M) Material on this page previously appeared on Page 22-45.

ACCESS SERVICE

22. Discount Plans (Cont'd)

22.1 National Discount Plan # (Cont'd)

22.1.7 Annual True-Up (Cont'd)

(C) Shortfall Penalty (Cont'd)

(2) As an illustrative example of the Shortfall Penalty calculation for the CT Commitment Level, assume that at the first Annual True-Up, an NDP Customer who selected the Premier Commitment Matrix had the following results: (i) the NDP Customer has met but has not exceeded by more than 60% its CM Commitment Level of 75,000 Equivalent DS1 CMs; (ii) the NDP Customer has not met its CT Commitment Level of 120,000 Equivalent DS1 CTs; and (iii) the Monthly Average Count of Equivalent DS1 CTs is 118,000. No Shortfall Penalty is applicable to NDP Customer's CM Commitment Level since NDP Customer has met its CM Commitment Level. Shortfall Penalty is due on the CT Commitment Level and is calculated as follows (using Steps 1-4 above):

(Step 1) Calculate the Monthly Average Count of Equivalent DS1 CTs. In this example, this number is 118,000 Equivalent DS1 CTs.

(Step 2) Calculate the Monthly Shortage of Equivalent DS1 CTs. [120,000 Commitment Level – 118,000 Monthly Average Count of Equivalent DS1 CTs = 2,000 Equivalent DS1 CTs]

(Step 3) Calculate the Lowest Monthly Rate per Equivalent DS1 CT. It is found that the lowest DS1 CT rate is \$201.13 in Florida, and the lowest average DS3 CT rate is \$847.35 for a protected individual DS3 without Telephone Company Electronics in California Zone 1, 2, or 3. The lowest DS3 rate divided by 28 is \$30.2625. Applying the Premier Commitment Tier C discount rate of 49.5% yields a Lowest Monthly Rate per Equivalent DS1 CT of \$15.283825.

(Step 4) Calculate the Shortfall Penalty. The Shortfall Penalty is \$366,811.80 (the Monthly Shortage of 2,000 Equivalent DS1 CTs x \$15.283825 Lowest Monthly Rate per Equivalent DS1 CT x 12 months).

Service availability is limited. See # footnote on Page 22-1.

ACCESS SERVICE

22. Discount Plans (Cont'd)

22.1 National Discount Plan # (Cont'd)

22.1.7 Annual True-Up (Cont'd)

(C) Shortfall Penalty (Cont'd)

- (3) The Telephone Company will apply the Shortfall Penalty calculated in (C)(1) preceding to the BANs designated by the NDP Customer under Section 22.1.2(C)(5) preceding. The Shortfall Penalty is not subject to late payment penalty under Section 2.4.1 preceding, except when the bill containing such Shortfall Penalty is not paid by the payment date.

(D) Discount Tier Adjustment

- (1) At each Annual True-Up, the Telephone Company will automatically adjust the Discount Tier(s) if the Achieved Discount Tier is a higher or a lower Discount Tier than the Assigned Discount Tier that was in effect during the Annual True-Up Period. Such action shall be referred to as the Discount Tier Adjustment. The Achieved Discount Tier and the Assigned Discount Tier are independently determined for Channel Terminations and Channel Mileage. For NDP Customers who elected either the Standard Commitment Matrix or the Premier Commitment Matrix, the Discount Tier Adjustment is set forth in Step 1 through Step 6 of (D)(2) following, the result of which may be an increase or decrease in the discount percentage that was applied during the Annual True-Up Period, and shall be reflected as a credit or debit on the NDP Customer's bill.

- (2) A Discount Tier Adjustment is calculated as follows:

- (Step 1) Calculate the Monthly Average Count of Equivalent DS1 CTs and the Monthly Average Count of Equivalent DS1 CMs during the Annual True-Up Period as set forth in Section 22.1.7(B)(1) preceding.

Service availability is limited. See # footnote on Page 22-1.

ACCESS SERVICE

22. Discount Plans (Cont'd)

22.1 National Discount Plan # (Cont'd)

22.1.7 Annual True-Up (Cont'd)

(D) Discount Tier Adjustment (Cont'd)

(2) (Cont'd)

(Step 2) Determine the Achieved Discount Tiers for the Monthly Average Count of Equivalent DS1 CTs and Monthly Average Count of Equivalent DS1 CMs, respectively.

(a) Using the Equivalent DS1 CT table set forth in Section 22.1.4(B)(1) preceding, (a) find the Achieved Discount Tier for the Monthly Average Count of Equivalent DS1 CTs determined in Step 1 above; and

(b) Using the Equivalent DS1 CM table set forth in Section 22.1.4(B)(2)(B) preceding, find the Achieved Discount Tier for the Monthly Average Count of Equivalent DS1 CMs determined in Step 1 above.

If an Achieved Discount Tier for Channel Terminations or Channel Mileage, as applicable, is the same Discount Tier as the Assigned Discount Tier for Channel Terminations or Channel Mileage, as applicable, no Discount Tier Adjustment will be made. In this case, Step 3 through Step 6 following do not apply.

For NDP Customers who elected the Standard Commitment Matrix or the Premier Commitment Matrix, if an Achieved Discount Tier for Channel Terminations or Channel Mileage, as applicable, is a higher or lower Discount Tier than the Assigned Discount Tier for Channel Terminations or Channel Mileage, as applicable, a Discount Tier Adjustment (as calculated in Steps 3 through Step 6) following applies.

Service availability is limited. See # footnote on Page 22-1.

ACCESS SERVICE

22. Discount Plans (Cont'd)

22.1 National Discount Plan # (Cont'd)

22.1.7 Annual True-Up (Cont'd)

(D) Discount Tier Adjustment (Cont'd)

(2) (Cont'd)

(Step 3) Calculate the Non-Discounted Billed Amounts.

The Non-Discounted Billed Amount(s) are (a) the total Monthly Charges for the Channel Termination and multiplexer Discounted Rate Elements that the NDP Customer would have paid during the Annual True-Up Period if the discount percentages as set forth in Section 22.1.5(B) preceding were not applied; and (b) the total Monthly Charges for the Channel Mileage Discounted Rate Elements that the NDP Customer would have paid during the Annual True-Up Period, if the discount percentages as set forth in Section 22.1.5(B) preceding were not applied. Discounted Rate Elements are specified in Section 22.1.5(A) preceding. The Non-Discounted Billed Amount(s) are calculated as follows.

(1)

(2)

(3)

(4)

(5) Calculate the Non-Discounted Billed Amount for Special Access DS1 Service SAL Discounted Rate Elements under FCC 14 and Special Access DS1 Service Circuit Termination Discounted Rate Elements under this Guide by (i) adding the billed Monthly Charges for all such SALs and Circuit Terminations in each month of the Annual True-Up Period; and (ii) then dividing the number derived in (i) preceding by one (1) minus the discount percentage associated with the Assigned Discount Tier for such Discounted Rate Element.

Service availability is limited. See # footnote on Page 22-1.

ACCESS SERVICE

22. Discount Plans (Cont'd)

22.1 National Discount Plan # (Cont'd)

22.1.7 Annual True-Up (Cont'd)

(D) Discount Tier Adjustment (Cont'd)

(2) (Cont'd)

(Step 3) (Cont'd)

(6) Calculate the Non-Discounted Billed Amount for Special Access DS3 SAL Discounted Rate Elements under FCC14 and Special Access DS3 Service Circuit Termination Discounted Rate Elements under this Guide by (i) adding the billed Monthly Charges for all such SALs and Circuit Terminations in each month of the Annual True-Up Period; and (ii) then dividing the number derived in (i) preceding by one (1) minus the discount percentage associated with the Assigned Discount Tier for such Discounted Rate Element.

(7)

(8)

(9) Calculate the Non-Discounted Billed Amount for Special Access DS1 Service Special Transport Discounted Rate Elements under FCC14 and Special Access DS1 Service Circuit Mileage under this Guide by (i) adding the billed Monthly Charges for all such Special Transport and Circuit Mileage in each month of the Annual True-Up Period; and (ii) then dividing the number derived in (i) preceding by one (1) minus the discount percentage associated with the Assigned Discount Tier for such Discounted Rate Element.

Service availability is limited. See # footnote on Page 22-1.

ACCESS SERVICE

22. Discount Plans (Cont'd)

22.1 National Discount Plan # (Cont'd)

22.1.7 Annual True-Up (Cont'd)

(D) Discount Tier Adjustment (Cont'd)

(2) (Cont'd)

(Step 3) (Cont'd)

(10) Calculate the Non-Discounted Billed Amount for Special Access DS3 Service Special Transport (including Banded Special Transport and Special Transport) Discounted Rate Elements under FCC14 and Special Access DS3 Service Circuit Mileage (including Banded Circuit Mileage and Circuit Mileage) under this Guide by (i) adding the billed Monthly Charges for all such Special Transport and Circuit Mileage in each month of the Annual True-Up Period; and (ii) then dividing the number derived in (i) preceding by one (1) minus the discount percentage associated with the Assigned Discount Tier for such Discounted Rate Element.

(Step 4) Calculate the difference in the discount percentages.

For each of the Discounted Rate Element categories specified in (1) through (10) of Step 3 above, using the discount percentages set forth in 22.1.5(B) preceding, individually calculate the difference between (i) the discount percentage of the Achieved Discount Tier; and (ii) the discount percentage of the Assigned Discount Tier.

For example, if the Assigned Discount Tier for SALs and circuit terminations under category (5) of Step 3 preceding has a discount percentage of 36% and the Achieved Discount Tier for category (5) of Step 3 preceding has a discount percentage of 35%, then the difference in the discount percentages is 1%.

Service availability is limited. See # footnote on Page 22-1.

ACCESS SERVICE

22. Discount Plans (Cont'd)

22.1 National Discount Plan # (Cont'd)

22.1.7 Annual True-Up (Cont'd)

(D) Discount Tier Adjustment (Cont'd)

(2) (Cont'd)

(Step 5) Individually calculate the dollar amount of the Discount Tier Adjustments.

For each Discounted Rate Element category specified in (1) through (10) of Step 3 above, individually calculate the dollar amount of the Discount Tier Adjustment by multiplying (i) the Non-discounted Billed Amount calculated for each Discounted Rate Element category in Step 3 above; by (ii) the difference in the discount percentage determined in Step 4 above for such Discounted Rate Element category.

(Step 6) Calculate the total Discount Tier Adjustment for the NDP.

(1) Add the total of the Discount Tier Adjustments for the Channel Termination and multiplexer rate elements as calculated in Step 5. The resulting total is the Discount Tier Adjustment for Channel Terminations and multiplexers.

(2) Add the total of the Discount Tier Adjustments for the Channel Mileage rate elements as calculated in Step 5. The resulting total is the Discount Tier Adjustment for Channel Mileage.

(3) For NDP Customers who elected the Standard Commitment Matrix or the Premier Commitment Matrix, Discount Tier Adjustments may result in a debit adjustment or credit adjustment to the NDP Customer's bill. The Telephone Company will apply the Discount Tier Adjustment calculated in (D)(2)(a) preceding to the BAN(s) designated by the NDP Customer under Section 22.1.2(C)(5) preceding. The Discount Tier Adjustment is not subject to late payment penalty under Section 2.4.1 preceding, except when the bill containing a debit Discount Tier Adjustment is not paid by the payment date.

Service availability is limited. See # footnote on Page 22-1.

ACCESS SERVICE

22. Discount Plans (Cont'd)

22.1 National Discount Plan # (Cont'd)

22.1.7 Annual True-Up (Cont'd)

(D) Discount Tier Adjustment (Cont'd)

(4) As an illustrative example of an adjustment to a higher Discount Tier for Channel Terminations, assume that (i) the NDP Customer is under the Premier Commitment Matrix; and (ii) the Assigned Discount Tier for Channel Terminations is Discount Tier D (120,001 to 195,000 Equivalent DS1 CTs) which provides a 36% discount for DS1 Channel Terminations; and (iii) no Discount Tier Adjustment is required for Channel Mileage because the NDP Customer's Achieved Discount Tier is the same as the Assigned Discount Tier for the Annual True-Up Period (i.e., the Telephone Company will disregard categories (7) through (10) of Step 3 in Section 22.1.7(D)(3) preceding).

(Step 1) Calculate the Monthly Average Count of Equivalent DS1 CTs in accordance with Section 22.1.7(B)(1) preceding. In this example, assume that this number is calculated as 201,000 Equivalent DS1 CTs.

(Step 2) Determine the Achieved Discount Tier in accordance with category (5) of Step 3 in Section 22.1.7(D)(2)(a) preceding. For purposes of this example, assume that Achieved Discount Tier for DS1 SALs and circuit terminations is Tier E (195,001 to 275,000 which has a 37% discount). Since the Monthly Average Count of Equivalent DS1 CTs is 201,000 Equivalent DSI CTs, the corresponding Achieved Discount Tier for Channel Terminations is Tier E (195,001 to 275,000 which has a corresponding discount percentage of 37% discount).

Since the Achieved Discount Tier (Tier E) is a higher Discount Tier than the Assigned Discount Tier (Tier D), proceed with Steps 3 through 6 of Section 22.1.7(D)(2)(a) preceding.

Service availability is limited. See # footnote on Page 22-1.

ACCESS SERVICE

22. Discount Plans (Cont'd)

22.1 National Discount Plan # (Cont'd)

22.1.7 Annual True-Up (Cont'd)

(D) Discount Tier Adjustment (Cont'd)

(4) (Cont'd)

(Step 3) Calculate the Non-Discounted Billed Amounts for each Channel Termination and multiplexer Discounted Rate Element category specified in Step 3 of Section 22.1.7(D)(2)(a) preceding.

The Non-Discounted Billed Amount for DS1 SALs and circuit terminations (i.e., category (5) of Step 3 in Section 22.1.7(D)(2)(a) preceding), is calculated as follows:

- (i) For this example, assume the total billed Monthly Charges for SALs and circuit terminations is \$12,000,000.
- (ii) Remove the discount associated with the Assigned Discount Tier [$\$12,000,000 / (1 - 0.36) = \$18,750,000$].

The monthly Non-Discounted Billed Amount for SALs and circuit terminations (i.e., category (5) of Step 3 in Section 22.1.7(D)(2)(a) preceding) is \$18,750,000.

In accordance with Step 3 of Section 22.1.7(D)(2)(a) preceding, calculate the monthly Non-Discounted Billed Amount for each of the remaining Channel Termination and multiplexer Discounted Rate Elements (categories (2) through (6) of Step 3 in Section 22.1.7(D)(2)(a) preceding).

Service availability is limited. See # footnote on Page 22-1.

ACCESS SERVICE

22. Discount Plans (Cont'd)

22.1 National Discount Plan # (Cont'd)

22.1.7 Annual True-Up (Cont'd)

(D) Discount Tier Adjustment (Cont'd)

(4) (Cont'd)

(Step 4) Calculate the difference in the discount percentage between the Assigned Discount Tier and the Achieved Discount Tier for the DS1 SALs and circuit terminations (i.e., category (5) of Step 3 in Section 22.1.7(D)(2)(a) preceding). For this Discounted Rate Element category, the difference is calculated as follows: [37% Achieved Discount Tier - 36% Assigned Discount Tier = 1% difference]

In accordance with Step 4 of Section 22.1.7(D)(2)(a) preceding, calculate the difference in the discount percentage between the Assigned Discount Tier and the Achieved Discount Tier for each of the remaining Channel Termination and multiplexer Discounted Rate Elements (i.e., categories (2) through (6) of Step 3 in Section 22.1.7(D)(2)(a) preceding).

(Step 5) Calculate the dollar amount of the Discount Tier Adjustments for the DS1 SALs and circuit terminations (i.e., category (5) of Step 3 in Section 22.1.7(D)(2)(a) preceding). For this Discounted Rate Element category, the dollar amount is calculated as follows [18,750,000 Non-Discounted Billed Amount from Step 3 x 1% difference in discount percentage from Step 4 = \$187,500].

In accordance with Step 5 of Section 22.1.7(D)(2)(a) preceding, calculate the dollar amount for each of the remaining Channel Termination and multiplexer Discounted Rate Elements (i.e., categories (2) through (6) of Step 3 in Section 22.1.7(D)(2)(a) preceding).

Service availability is limited. See # footnote on Page 22-1.

ACCESS SERVICE

22. Discount Plans (Cont'd)

22.1 National Discount Plan # (Cont'd)

22.1.7 Annual True-Up (Cont'd)

(D) Discount Tier Adjustment (Cont'd)

(4) (Cont'd)

(Step 5) (Cont'd)

Assume the calculations in Steps 3 through 5 preceding are done for each of the remaining Channel Termination and multiplexer Discounted Rate Elements (i.e., categories (2) through (6) of Step 3 in Section 22.1.7(D)(2)(a) preceding). Further assume the calculations yield the following Discount Tier Adjustments:

DS1 CT this Guide & FCC16	\$100,000
DS3 CT this Guide & FCC16	\$200,000

(Step 6) Calculate the Total Discount Tier Adjustment in accordance with Step 6 of Section 22.1.7(D)(2)(a) preceding. The total Discount Tier Adjustment for Channel Termination and multiplexer Discounted Rate Elements is equal to \$300,000 [\$100,000 + \$200,000]. The NDP Customer would receive a credit of \$300,000 on its BANs for this Discount Tier Adjustment.

(5) No change will be made to the NDP Customer's Commitment Levels, regardless of whether or not the Discount Tier was adjusted upward or downward. An NDP Customer subscribed to the Premier Commitment Matrix may qualify for the Commitment Buy-Up Bonus Option and receive a CBB Discount under Section 22.1.7(E) following.

Service availability is limited. See # footnote on Page 22-1.

ACCESS SERVICE

22. Discount Plans (Cont'd)

22.1 National Discount Plan # (Cont'd)

22.1.7 Annual True-Up (Cont'd)

(E) Commitment Buy-Up Bonus

During an Annual True-Up, an NDP Customer that meets the following criteria may choose to exercise the Commitment Buy-Up Bonus option. The CBB Discount is provided in connection with the Annual True-Up Period, and is in addition to any other discounts provided under NDP.

- (1) If the NDP Customer meets all of the requirements of (a) through (c) following, the NDP Customer is eligible to exercise the Commitment Buy-Up Bonus Option with respect to either or both Commitment Levels:
 - (a) the NDP Customer subscribes to the Premier Commitment Matrix during the Annual True-Up Period; and
 - (b) the NDP Customer has met both its CT Commitment Level and its CM Commitment Level (assuming it established both such Commitment Levels) under Section 22.1.7(B) preceding; and
 - (c) the actual quantity of Equivalent DS1 CTs or Equivalent DS1 CMs, as applicable, in month twelve (12) of the Annual True-Up Period is five percent (5%) or more greater than the actual quantity of Equivalent DS1 CTs or CMs, as applicable, in month one (1) of the Annual True-Up Period.
- (2) If the NDP Customer elects to increase its CT Commitment Level and/or CM Commitment Level, the new Commitment Level(s) for the NDP will be set at ninety (90%) of the month 12 count of Equivalent DS1 CTs; or at ninety (90%) of the month 12 count of Equivalent DS1 CMs, as applicable. In determining the month 12 counts, the Telephone Company will include any Upgrade Adjustment or Sale Adjustment as set forth in Sections 22.1.7(H) and 22.1.10 following, respectively.

Service availability is limited. See # footnote on Page 22-1.

ACCESS SERVICE

22. Discount Plans (Cont'd)

22.1 National Discount Plan # (Cont'd)

22.1.7 Annual True-Up (Cont'd)

(E) Commitment Buy-Up Bonus (Cont'd)

(3) Where an increase in (E)(2) above occurs, the CBB Discount shall be calculated in accordance with (E)(4) following, and such calculation shall use the Percent Increase and corresponding CBB Discount Percentage achieved by the NDP Customer in accordance with the table below:

Percent Increase	CBB Discount Percentage
Less than 5%	No Discount
5% - 9.99%	1%
10% - 14.99%	2%
15% - 19.99%	3%
20% - 24.99%	4%
25% or more	5%

(4) The CBB Discount is calculated as follows.

(Step 1) Calculate the Percent Increase and Corresponding CBB Discount Percentage

A Percent Increase will be calculated for the Equivalent DS1 CTs and a separate Percent Increase will be calculated for the Equivalent DS1 CMs.

(a) The Percent Increase for the Equivalent DS1 CTs is calculated as follows:

(1) subtract (i) the actual count of Equivalent DS1 CTs in month one (1) of the Annual True-Up Period; from (ii) the actual count of Equivalent DS1 CTs in month twelve (12) of the Annual True-Up Period; and

(2) divide the result from (a)(1) preceding by the actual count of Equivalent DS1 CTs in month one (1) of the Annual True-Up Period.

Service availability is limited. See # footnote on Page 22-1.

ACCESS SERVICE

22. Discount Plans (Cont'd)

22.1 National Discount Plan # (Cont'd)

22.1.7 Annual True-Up (Cont'd)

(E) Commitment Buy-Up Bonus (Cont'd)

(4) (Cont'd)

(Step 1) Calculate the Percent Increase and Corresponding CBB Discount Percentage (Cont'd)

(b) The Percent Increase for the Equivalent DS1 CM is calculated as follows:

- (1) subtract (i) the actual count of Equivalent DS1 CMs in month one (1) of the Annual True-Up Period; from (ii) the actual count of Equivalent DS1 CMs in month twelve (12) of the Annual True-Up Period; and
- (2) divide the result from (b)(1) preceding by the actual count of Equivalent DS1 CMs in month one (1) of the Annual True-Up Period.

The applicable CBB Discount Percentage is derived from the table in Section 22.1.7(E)(3) preceding by using the Percent Increase as calculated in this Step 1. The CBB Discount Percentage is separately derived for Channel Terminations and Channel Mileage from the table in Section 22.1.7(E)(3) preceding.

For example, if the Percent Increase (as calculated in Step 1) for Equivalent DS1 CTs is 11%, and the Percent Increase for Equivalent DS1 CMs is 23%, then the corresponding CBB Discount Percentage from the table in (E)(3) preceding is 2% for Equivalent DS1 CTs and 4% for Equivalent DS1 CMs.

(Step 2) Calculate the Monthly Average Count of Equivalent DS1 CTs or Monthly Average Count of Equivalent DS1 CMs

Calculate the Monthly Average Count of Equivalent DS1 CTs in accordance with Step 1 of Section 22.1.7(B)(1) preceding and/or the Monthly Average Count of Equivalent DS1 CMs in accordance with Step 1 of Section 22.1.7(B)(1) preceding, as applicable.

Service availability is limited. See # footnote on Page 22-1.

ACCESS SERVICE

22. Discount Plans (Cont'd)

22.1 National Discount Plan # (Cont'd)

22.1.7 Annual True-Up (Cont'd)

(E) Commitment Buy-Up Bonus (Cont'd)

(4) (Cont'd)

- (Step 3) Calculate the Average Monthly Rate per Equivalent DS1 CTs or Equivalent DS1 CMs

The Average Monthly Rate per Equivalent DS1 CT is calculated in accordance with Step 3 of Section 22.1.7(C)(1) preceding.

The Average Monthly Rate per Equivalent DS1 CM is calculated in accordance with Step 3 of Section 22.1.7(C)(2) preceding.

- (Step 4) Calculate the Actual Increase in Equivalent DS1 CTs and Equivalent DS1 CMs

The Actual Increase in the count of Equivalent DS1 CTs or Equivalent DS1 CMs, as applicable, is calculated by subtracting (i) the number of Equivalent DS1 CTs or Equivalent DS1 CMs (as applicable) in month one (1) of the Annual True-Up Period; from (ii) the number of Equivalent DS1 CTs or Equivalent DS1 CMs (as applicable) in month twelve (12) of the Annual True-Up Period.

- (Step 5) Calculate the CBB Discount

The CBB Discount is equal to the product of the following:

- (a) the Average Monthly Rate per Equivalent DS1 CT or Equivalent DS1 CM, as applicable, as determined in Step 3 preceding; multiplied by
- (b) the Actual Increase determined in Step 4 preceding; multiplied by
- (c) the applicable CBB Discount Percentage determined in Step 1; multiplied by
- (d) 12 months.

Service availability is limited. See # footnote on Page 22-1.

ACCESS SERVICE

22. Discount Plans (Cont'd)

22.1 National Discount Plan # (Cont'd)

22.1.7 Annual True-Up (Cont'd)

(E) Commitment Buy-Up Bonus (Cont'd)

(5) As an illustrative example of the Commitment Buy-Up Bonus and the calculation of the CBB Discount for the CT Commitment Level, assume that the actual number of Equivalent DS1 CTs in month one (1) of the Annual True-Up Period was 6,046 Equivalent DS1 CTs and the actual number of Equivalent DS1 CTs in month twelve (12) of the Annual True-Up Period was 7,001.

(Step 1) Calculate the Percent Increase and corresponding CBB Discount Percentage in accordance with Step 1 of Section 22.1.7(E)(4) preceding.
In this example, the Percent Increase for Equivalent DS1 CTs is 16% $[(7,001 - 6,046)/6,046]$. The corresponding CBB Discount Percentage per the table in Section 22.1.7(E)(3) preceding is 3%.

(Step 2) Calculate the Monthly Average Count of Equivalent DS1 CTs in accordance with Step 2 of Section 22.1.7(E)(4) preceding. For this example, assume that the Monthly Average Count of Equivalent DS1 CTs is 6,350 Equivalent DS1 CTs.

(Step 3) Calculate the Average Monthly Rate per Equivalent DS1 CT in accordance with Step 3 of Section 22.1.7(E)(4) preceding. For this example, assume that the total charges over the Annual True-Up Period were \$9,475,000 which results in an average of \$124.34 per Equivalent DS1 CT. $[(9,475,000 \text{ divided by } 12 \text{ months}) = \$789,583]$ $[\$789,583 \text{ divided by } 6,350 = \text{an Average Monthly Rate of Equivalent DS1 CTs is } \$124.34 \text{ per Equivalent DS1 CT}]$

(Step 4) Determine the Actual Increase in Equivalent DS1 CTs in accordance with Step 4 of Section 22.1.7(E)(4) preceding. In this example, the Actual Increase for Equivalent DS1 CTs is 955 Equivalent DS1 CTs $(7,001 - 6046)$.

(Step 5) Determine the CBB Discount for the CT Commitment Level in accordance with Step 5 of Section 22.1.7(E)(4) preceding. In this example, the CBB Discount is \$42,748 $[955 \text{ Actual Increase} \times \$124.34 \text{ Average Rate per Equivalent DS1 CT} \times 3\% \text{ Percent Increase} \times 12 \text{ months} = \$42,748 \text{ CBB Discount}]$.

Service availability is limited. See # footnote on Page 22-1.

ACCESS SERVICE

22. Discount Plans (Cont'd)

22.1 National Discount Plan # (Cont'd)

22.1.7 Annual True-Up (Cont'd)

(F) Assign the Discount Tier(s) for the Next Plan Year

The Telephone Company will assign the Discount Tier(s) applicable to the next Plan Year (i.e., from the most recent Anniversary Date to the next successive Anniversary Date) if the Achieved Discount Tier in month twelve (12) of the Annual True-Up Period (taking into account any (i) Upgrade Adjustment, as calculated in accordance with Section 22.1.7(H) following, for any Qualifying Service(s) that has been Upgraded; and (ii) any Sale Adjustment, as calculated in accordance with Section 22.1.10 following, for any Qualifying Service(s) which are affected by a Telephone Company Sale) is a higher or lower Discount Tier than the Assigned Discount Tier for the Annual True-Up Period. With respect to either Channel Terminations or Channel Mileage, the new Discount Tier for the next Plan Year (i.e., the new Assigned Discount Tier) shall result in an increased or decreased discount percentage pursuant to Section 22.1.5(B) preceding. If the Achieved Discount Tier (as determined in accordance with Section 22.1.7(D) preceding) is the same as the Assigned Discount Tier for the Annual True-Up, no action will be taken.

For example, assume that the NDP Customer's Assigned Discount Tier in Plan Year 2 for Channel Mileage Discounted Rate Elements was Discount Tier B. Further assume that the NDP Customer's Achieved Discount Tier for such Channel Mileage Discounted Rate Elements in month 12 of the Annual True-Up Period was Discount Tier C. In this case, the Telephone Company will assign Discount Tier C as the Discount Tier for the next Plan Year.

Service availability is limited. See # footnote on Page 22-1.

ACCESS SERVICE

22. Discount Plans (Cont'd)

22.1 National Discount Plan # (Cont'd)

22.1.7 Annual True-Up (Cont'd)

(G) Changes to Commitment Matrix During an Annual-True-Up

(1) Permitted Changes:

If the NDP Customer has selected the Standard Commitment Matrix at the beginning of the Initial Term or the Renewal Term, as applicable, the NDP Customer may, at its option, change its Commitment Matrix selection to either the Deluxe Commitment Matrix or the Premier Commitment Matrix at an Annual True-Up. If the NDP Customer has selected the Deluxe Commitment Matrix at the beginning of the Initial Term or the Renewal Term, as applicable, the NDP Customer may, at its option, change its Commitment Matrix selection to the Premier Commitment Matrix at an Annual True-Up. Such request must be in writing and made no later than thirty (30) calendar days prior to the Anniversary Date of the NDP Customer's NDP. The Telephone Company will set the new Commitment Levels based on the Commitment Matrix selected in accordance with Section 22.1.4(C) preceding. Such new Commitment Levels shall apply on a going forward basis for the balance of the Initial Term or Renewal Term, as applicable.

(2) Prohibited Changes

If the NDP Customer has selected the Premier Commitment Matrix at the beginning of the Initial Term or the Renewal Term, as applicable, the NDP Customer may not change such Commitment Matrix during the Initial Term, or during a Renewal Term, as applicable, including during an Annual True-Up. If the NDP Customer has selected the Deluxe Commitment Matrix at the beginning of the Initial Term or the Renewal Term, as applicable, the NDP Customer may not change such Commitment Matrix to the Standard Commitment Matrix during the Initial Term, or during a Renewal Term, as applicable, including during an Annual True-Up.

(3) Certain Other Changes to the Commitment Matrix

As described further in Section 22.1.14 following, at the end of the Initial Term or any Renewal Term, as applicable, an NDP Customer that renews its NDP is permitted to pick a different Commitment Matrix for the Renewal Term, so long as the NDP Customer does not also concurrently select the Renewal Benefit Option.

Service availability is limited. See # footnote on Page 22-1.

ACCESS SERVICE

22. Discount Plans (Cont'd)

22.1 National Discount Plan # (Cont'd)

22.1.7 Annual True-Up (Cont'd)

(H) Upgrades

- (1) For customers who subscribe to NDP on or after December 2, 2010, or renew an expiring NDP on or after December 2, 2010, the NDP customer may disconnect a Qualifying Service in order to replace such Qualifying Service with a Replacing Service pursuant to Section 2.10 preceding.

For customers who subscribed to an NDP prior to December 2, 2010, this Section 22.1.7(H) includes replacements of Qualifying Services with Telephone Company provided Ethernet private line service or a Telephone Company provided switched Ethernet service. However, the customer may, at its option, replace a Qualifying Service with a Replacing Service pursuant to Section 2.10 preceding in lieu of this Section 22.1.7(H).

- (2) During the Term of the NDP, an NDP Customer may Upgrade a Qualifying Service to a service that is (a) a Qualifying Service of a higher capacity/bandwidth (e.g., an Upgrade of a Special Access DS3 Service to a DSEF Service); or (b) a non-Qualifying Service of a higher bandwidth/capacity (e.g., an Upgrade of a Special Access DS3 Service to a Telephone Company provided optical service of a greater bandwidth). An Upgrade under (a) above shall result in no change to the NDP Customer's NDP.

Service availability is limited. See # footnote on Page 22-1.

ACCESS SERVICE

22. Discount Plans (Cont'd)

22.1 National Discount Plan # (Cont'd)

22.1.7 Annual True-Up (Cont'd)

(H) Upgrades (Cont'd)

- (3) Except as otherwise specified in Sections 2.10.4 and 2.10.5 preceding for a Technology Migration, an Upgrade must meet all of the following conditions:
- (a) Both the Qualifying Service being Upgraded (the existing service) and the replacing Qualifying Service or non-Qualifying Service, as applicable, (the new service), must be provided solely by the Telephone Company;
 - (b) at least one of the terminating locations of the new service must be the same location as one of the terminating locations of the existing service; and
 - (c) the total bandwidth or capacity of the new service must be equal to or greater than the total bandwidth or capacity of the existing service; and
 - (d) the NDP Customer must submit order(s) for the disconnect of the existing service and the installation of the new service, such that the installation date of the new service is within ninety (90) days of the disconnection of the existing service. The orders must be related by related purchase order number (RPON); and
 - (e) The commitment period for the new service must be at least five (5) years, except where a commitment period of at five (5) years or longer is not available, in which case the longest available commitment period must be selected; and
 - (f) At each next Annual True-Up following the Upgrade, the new service must be installed and still in-service to be eligible for an Upgrade Adjustment as set forth in (H)(3) following.
 - (g) No later than thirty (30) days prior to the Anniversary Date of the NDP, the NDP Customer must provide the Telephone Company with a list of the existing services (as defined in (H)(2)(a) above) that were Upgraded to non-Qualifying Services (as defined in (H)(2)(a) above) during the Annual True-Up Period. The list must be in writing and must contain the following information:
 - (i) the circuit identification number for each existing service; and
 - (ii) the circuit identification number for each new service; and
 - (iii) the RPONs associated with the Upgrades.

Service availability is limited. See # footnote on Page 22-1.

ACCESS SERVICE

22. Discount Plans (Cont'd)

22.1 National Discount Plan # (Cont'd)

22.1.7 Annual True-Up (Cont'd)

(H) Upgrades (Cont'd)

(4) With the exception of an Upgrade involving a Technology Migration pursuant to Section 2.9 preceding, when a Qualifying Service is Upgraded to a non-Qualifying Service, the Telephone Company will calculate the Upgrade Adjustment (i.e., an adjusted number of Equivalent DS1 CTs for the Qualifying Services that were Upgraded (in accordance with (a) following), and an adjusted number of Equivalent DS1 CMs for the Qualifying Services that were Upgraded (in accordance with (b) following). The Telephone Company shall use such Upgrade Adjustments in (i) the calculation of Step 2 of the Monthly Average Count of Equivalent DS1 CTs and the Monthly Average Count of Equivalent DS1 CMs, respectively, as set forth in Section 22.1.7(B)(1) preceding; (ii) Section 22.1.7(F) for assigning Discount Tiers for the next Plan Year; and (iii) Section 22.1.7(E) to set the new Commitment Level(s) when the NDP Customer elects the Commitment Buy-Up Option.

(a) The Upgrade Adjustment of Equivalent DS1 CTs is calculated as follows.

- (1) Using the table in Section 22.1.4(A)(1) preceding, determine the number of Equivalent DS1 CTs associated with the Qualifying Service(s) that were Upgraded to a non-Qualifying Service as calculated in accordance with Section 22.1.4(A).
- (2) Determine the number of whole calendar months remaining in the Annual True-Up Period following the month in which the Upgrade occurred through the end of the Annual True-Up Period. For example, if the Upgrade occurred in June, and the Annual True-Up Period ended in November, then the number of whole months remaining in the Annual True-Up Period was five (5) months; and
- (3) Determine the Upgrade Adjustment of Equivalent DS1 CTs by multiplying (a) the result of (1) above; by (b) the result of (2) above. The Telephone Company shall use such Upgrade Adjustments in the calculation of Step 2 of the Monthly Average Count of Equivalent DS1 CTs, as set forth in Section 22.1.7(B)(1) preceding.

Service availability is limited. See # footnote on Page 22-1.

ACCESS SERVICE

22. Discount Plans (Cont'd)

22.1 National Discount Plan # (Cont'd)

22.1.7 Annual True-Up (Cont'd)

(H) Upgrades (Cont'd)

(4) (Cont'd)

(a) (cont'd)

As an example, assume the NDP Customer Upgraded two (2) Special Access DS3 Services to a Telephone Company provided optical Service in the seventh (7th) month of the Annual True-Up Period. The Upgrade Adjustment of Equivalent DS1 CTs is calculated as follows:

- (1) multiply the number of DS3 level Qualifying Services that were Upgraded by the corresponding DS1 CT Multiplier. [2 Special Access DS3 Services x 28 =56 Equivalent DS1 CTs]
 - (2) five (5) months remain in the Annual True-Up Period. [the Upgrade occurred in the 7th month of the Annual True-Up Period which is period of twelve(12) months]
 - (3) the Upgrade Adjustment used in the calculation set forth in Step 2(i) of Section 22.1.7(B)(1) preceding would be 280 Equivalent DS1s. [56 Equivalent DS1 CTs upgraded in (i) above multiplied by 5 months as determined in (2) above]. This number shall be used in Step 2(i) of the calculation of Monthly Average DS1 CTs as set forth in Section 22.1.7(B)(1) preceding.
- (b) The Upgrade Adjustment of Equivalent DS1 CMs is calculated in the same manner as the Upgrade Adjustment of Equivalent DS1 CT specified in (H)(3)(a) preceding is calculated, except that such calculations shall use Equivalent DS1 CMs and DS1 CM multipliers. This number shall be used in Step 2(i) of the calculation of Monthly Average DS1 CMs as set forth in Section 22.1.7(B)(1) preceding.

Service availability is limited. See # footnote on Page 22-1.

ACCESS SERVICE

22. Discount Plans (Cont'd)

22.1 National Discount Plan # (Cont'd)

22.1.8 Minimum Period

The minimum period, as set forth in Section 7.2.2 preceding, for any service associated with a Discounted Rate Element provided under the NDP is one year from the date that such service is installed. Minimum period charges, as calculated in Section 5.3.3 preceding, will be assessed if the NDP Customer does not maintain the service with Discounted Rate Elements under Section 22.1.5 preceding for at least the one year minimum period.

As an illustrative example, assume that the NDP Customer establishes a Special Access DS1 Service under a TPP on January 1, 2001. On June 1, 2007, the NDP Customer establishes the NDP. On November 1, 2007, the NDP Customer disconnects that Special Access DS1 Service that was originally installed on January 1, 2001. Since the service was installed on January 1, 2001, and the disconnection date was November 1, 2007, the minimum period under the NDP of one year has been met. Therefore, the NDP Customer is not required to pay any minimum period charges.

22.1.9 Changes to Basic Service and/or Base Rates

The Basic Service or Base Rates to which the discount percentages are applied under the NDP are subject to change. An increase in the Basic Service rate (used with Special Access DS1 Service only) or Base Rate (used with Special Access DS3 Service only) will result in an increase to the rates under the NDP for the applicable Special Access DS1 Service and Special Access DS3 Services. A decrease in the Basic Service rate or Base Rate will result in a decrease to the rates under the NDP for the applicable Qualifying Service.

Service availability is limited. See # footnote on Page 22-1.

ACCESS SERVICE

22. Discount Plans (Cont'd)

22.1 National Discount Plan # (Cont'd)

22.1.10 Sale of a Telephone Company Operating Territory

(A) In the event of a Telephone Company Sale during a Plan Year, the following applies:

- (1) The Telephone Company will determine and record the actual number of Equivalent DS1 CTs and the actual number of Equivalent DS1 CMs affected by the Telephone Company Sale; and
- (2) If a Telephone Company Sale occurs during the Initial Term, or a Renewal Term, the Telephone Company will calculate the Sale Adjustment (i.e., an adjusted amount of Equivalent DS1 CTs which are no longer provided to the NDP Customer as a result of the Telephone Company Sale, and/or an adjusted amount of Equivalent DS1 CMs which are no longer provided to the NDP Customer as a result of the Telephone Company Sale, as applicable). The Telephone Company shall use both of such Sale Adjustments in the Annual True-Up for the balance of the Initial Term or the Renewal Term, as applicable. Specifically, during the Annual True-Up, the Telephone Company shall use both of such Sale Adjustments in (i) the calculation of Step 2(ii) of the Monthly Average Count of Equivalent DS1 CTs and the Monthly Average Count of Equivalent DS1 CMs, respectively, as set forth in Section 22.1.7(B)(1) preceding, either during the Initial Term or the Renewal Term; (ii) Section 22.1.7(F) preceding for assigning Discount Tiers for the next Plan Year; and (iii) Section 22.1.7(E) preceding to set the new Commitment Level(s) when the NDP Customer elects the Commitment Buy-Up Option.

Service availability is limited. See # footnote on Page 22-1.

ACCESS SERVICE

22. Discount Plans (Cont'd)

22.1 National Discount Plan # (Cont'd)

22.1.10 Sale of a Telephone Company Operating Territory (Cont'd)

(A) (Cont'd)

(2) (Cont'd)

- (a) When calculating the Monthly Average Count of Equivalent DS1 CTs under Section 22.1.7(B)(1) preceding, the Telephone Company will calculate the Sale Adjustment of Equivalent DS1 CTs (as used in Step 2(ii) of Section 22.1.7(B)(1) preceding) for each Qualifying Service included in the Telephone Company Sale.

The Sale Adjustment of Equivalent DS1 CTs is calculated as follows:

- (i) Using the table in Section 22.1.4(A)(1) preceding, determine the number of Equivalent DS1 CTs associated with the Qualifying Service(s) that were sold as calculated in accordance with Section 22.1.4(A)(1) preceding.
- (ii) Determine the number of whole calendar months remaining in the Annual True-Up Period following the month in which the Telephone Company Sale occurred through the end of the Annual True-Up Period. For example, if the Telephone Company Sale occurred in April, and the Annual True-Up Period ended in August, then the number of whole months remaining in the Annual True-Up Period was four (4) months; and
- (iii) Determine the Sale Adjustment of Equivalent DS1 CTs by multiplying (a) the result of (i) above; by (b) the result of (ii) above. The Telephone Company shall use such Sale Adjustment(s) in the calculation of Step 2(ii) of the Monthly Average Count of Equivalent DS1 CTs as set forth in Section 22.1.7(B)(1) preceding.
- (b) The Sale Adjustment of Equivalent DS1 CMs is calculated in the same manner as the Sale Adjustment of Equivalent DS1 CTs is calculated in (a) above, except that such calculations shall use Equivalent DS1 CMs and DS1 CM Multipliers instead of Equivalent DS1 CTs and DS1 CT Multipliers.

Service availability is limited. See # footnote on Page 22-1.

ACCESS SERVICE

22. Discount Plans (Cont'd)

22.1 National Discount Plan # (Cont'd)

22.1.11 Addition of an ACNA(s) to an Existing NDP

(A) One of the following two (2) options must be chosen by the NDP Customer when adding one or more ACNA(s) to its NDP:

- (1) If an NDP Customer adds one or more ACNA(s) to its NDP (as permitted under Section 22.1.1(C) preceding), and such ACNA(s) is/are not already included in a different NDP, then the NDP Customer must include such ACNA(s) in its NDP in accordance with the terms of Section 22.1.11(B)(1) following; or
- (2) If an NDP Customer adds one or more ACNA(s) to its NDP (as permitted under Section 22.1.1(C) preceding), and such ACNA(s) is/are already included in another NDP, then the NDP Customer must include such ACNA(s) in its NDP in accordance with the terms of Section 22.1.11(B)(2) following.

The terms of Section 22.1.1(C) preceding apply in addition to any requirements set forth herein.

(B) No later than thirty (30) calendar days prior to each Anniversary Date of the NDP, the NDP Customer must provide the Telephone Company with a list of the any ACNAs that the NDP Customer acquired (as defined in (A) above) during the Annual True-Up Period. Whether the acquired ACNA(s) is/are already included in an NDP shall determine whether (i) the NDP Customer's NDP is augmented to include such acquired ACNA(s); (ii) the NDP Customer's NDP is combined with the NDP associated with the acquired ACNA(s); or (iii) a new NDP is established that includes the NDP Customer existing ACNA(s) and the acquired ACNAs.

Service availability is limited. See # footnote on Page 22-1.

ACCESS SERVICE

22. Discount Plans (Cont'd)

22.1 National Discount Plan # (Cont'd)

22.1.11 Addition of an ACNA(s) to an Existing NDP (Cont'd)

(B) (Cont'd)

(1) Augment of Existing NDP to Include the Added ACNA(s)

Where an NDP Customer seeks to add one or more ACNA(s) to its NDP in accordance with Section 22.1.11(A)(1) preceding (i.e., such ACNA(s) is/are not already included in another NDP), the NDP Customer's NDP shall be augmented to include the quantities of the Qualifying Services of such added ACNAs.

- (a) At the next Annual True-Up following the effective date of the NDP Customer acquiring the additional ACNA(s), the Telephone Company will complete Steps (A)(1) through (A)(5) of the Annual True-Up as described in Section 22.1.7(A) preceding as if the NDP Customer had not acquired the additional ACNA(s).
- (b) Upon completion of Section 22.1.7(A)(1) through (A)(5) preceding, and in accordance with Section 22.1.1(C) preceding, the acquired ACNA(s) will be added to the NDP and all of the following shall occur:

(1) Adjust Commitment Levels

The Telephone Company will adjust Commitment Levels of the NDP to include the Qualifying Services of the acquired ACNA(s) as follows:

Service availability is limited. See # footnote on Page 22-1.

ACCESS SERVICE

22. Discount Plans (Cont'd)

22.1 National Discount Plan # (Cont'd)

22.1.11 Addition of an ACNA(s) to an Existing NDP (Cont'd)

(B) (Cont'd)

(1) (Cont'd)

(b) (Cont'd)

(1) Adjust Commitment Levels (Cont'd)

(Step 1) Using the table in Section 22.1.4(A)(1) preceding, and the actual quantities of Channel Terminations for the acquired ACNA(s) in month twelve (12) of the Annual True-Up Period (even though such Channel Terminations of the acquired ACNA(s) were not used in the Annual True-Up), determine the number of Equivalent DS1 CTs associated with the Qualifying Service(s) of the acquired ACNA(s) by multiplying (a) the level for the Qualifying Service (e.g., DS3 level); by (b) the DS1 CT multiplier using the table set forth in Section 22.1.4(A)(1) preceding.

The Telephone Company will determine the number of Equivalent DS1 CMs for the acquired ACNA(s) in the same manner as the number of Equivalent DS1 CTs was developed in the preceding paragraph.

(Step 2) The Telephone Company will calculate a CT Commitment Level for the acquired ACNA(s) by multiplying the result in Step 1 above by eighty-five percent (85%) if the NDP Customer has the Standard Commitment Matrix, by ninety percent (90%) if the NDP Customer has the Premier Commitment Matrix, or by ninety-two percent (92%) if the NDP Customer has the Deluxe Commitment Matrix.

The Telephone Company will develop a CM Commitment Level for the acquired ACNA(s) in the same manner as the CT Commitment Level was developed in the preceding paragraph.

Service availability is limited. See # footnote on Page 22-1.

ACCESS SERVICE

22. Discount Plans (Cont'd)

22.1 National Discount Plan # (Cont'd)

22.1.11 Addition of an ACNA(s) to an Existing NDP (Cont'd)

(B) (Cont'd)

(1) (Cont'd)

(b) (Cont'd)

(1) Adjust Commitment Levels (Cont'd)

(Step 3) The Telephone Company will add the CT Commitment Level for the acquired ACNA(s) determined in Step 2 above to the CT Commitment Level for the NDP (which such CT Commitment Level may have already been revised in accordance with Section 22.1.7(B) or Section 22.1.7(E) preceding, of the Annual True-Up), the result of which will be the adjusted CT Commitment Level for the remainder of the Term unless otherwise adjusted in this Section 22.1. Any prior CT Commitment level established under Section 22.1.7(B) or Section 22.1.7(E) preceding is expressly superseded by the CT Commitment Level established under this Step 3.

The Telephone Company will add the CM Commitment Level for the acquired ACNA(s) determined in Step 2 above to the CM Commitment Level for the NDP, the result of which will be the adjusted CM Commitment Level for the remainder of the Term unless otherwise adjusted in this Section 22.1. Any prior CM Commitment level established under Section 22.1.7(B) or Section 22.1.7(E) preceding is expressly superseded by the CM Commitment Level established under this Step 3.

Service availability is limited. See # footnote on Page 22-1.

ACCESS SERVICE

22. Discount Plans (Cont'd)

22.1 National Discount Plan # (Cont'd)

22.1.11 Addition of an ACNA(s) to an Existing NDP (Cont'd)

(B) (Cont'd)

(1) (Cont'd)

(b) (Cont'd)

(1) Adjust Commitment Levels (Cont'd)

As an example, assume the NDP Customer's CT Commitment Level is 10,000 Equivalent DS1 CTs. Further assume that the NDP Customer acquired one ACNA with Qualifying Services in month twelve (12) of the Annual True-Up Period in the following quantities (a) nine (9) Special Access DS3 Services; and (b) two thousand (2000) Special Access DS1 Services. The adjustment to the CT Commitment Level is calculated as:

- (Step 1) determine the quantity of Equivalent DS1 CTs for the acquired ACNA(s) by multiplying
- (i) the number of DS3 level Qualifying Services for the acquired ACNA(s); by
 - (ii) the corresponding DS3 CT Multiplier [9 Special Access DS3 Services x 28 =252 Equivalent DS1 CTs].
 - (iii) Then, multiply the number of DS1 level Qualifying Services for the acquired ACNA(s); by
 - (iv) the corresponding DS1 CT Multiplier [2000 Special Access DS1 Services x 1 = 2000 Equivalent DS1 CTs].
 - (v) add the result of (ii) and (iv) above [252 for DS3 Level + 2000 for DS1 Level = 2252 Equivalent DS1 CTs].

Service availability is limited. See # footnote on Page 22-1.

ACCESS SERVICE

22. Discount Plans (Cont'd)

22.1 National Discount Plan # (Cont'd)

22.1.11 Addition of an ACNA(s) to an Existing NDP (Cont'd)

(B) (Cont'd)

(1) (Cont'd)

(b) (Cont'd)

(1) Adjust Commitment Levels (Cont'd)

Example (Cont'd)

(Step 2) Calculate the increase to the CT Commitment Level by multiplying the result in Step 1 above by eighty-five percent (85%) for the Standard Commitment Matrix, by ninety percent (90%) for the Premier Commitment Matrix, or by ninety-two percent (92%) for the Deluxe Commitment Matrix. In this example, assume the NDP Customer has Premier Commitment Matrix [2252 Equivalent DS1 CTs for the acquired ACNA x 90% Commitment for Premier Commitment Matrix = 2027 Equivalent DS1 CTs (i.e., the Commitment Level for the acquired ACNA)].

(Step 3) Add the CT Commitment Level for the acquired ACNA determined in Step 2 above to the CT Commitment Level for the remaining portion of the NDP (which such CT Commitment Level may have already been revised in accordance with Section 22.1.7(B) and Section 22.1.7(E) preceding, of the Annual True-Up) (assumed to be 10,000 Equivalent DS1 CTs in this example) to determine the revised CT Commitment Level for the remainder of the Term unless otherwise changed in this Section 22.1. [10,000 Equivalent DS1 CTs for the existing CT Commitment Level + 2027 Equivalent DS1 CTs for the CT Commitment Level of the acquired ACNAs = a revised CT Commitment Level for the NDP of 12,027 Equivalent DS1 CTs]. Any prior CT Commitment level established under Section 22.1.7(B) and Section 22.1.7(E) preceding is expressly superseded by the CT Commitment Level established under this Step 3.

Service availability is limited. See # footnote on Page 22-1.

ACCESS SERVICE

22. Discount Plans (Cont'd)

22.1 National Discount Plan # (Cont'd)

22.1.11 Addition of an ACNA(s) to an Existing NDP (Cont'd)

(B) (Cont'd)

(1) (Cont'd)

(b) (Cont'd)

(1) Adjust Commitment Levels (Cont'd)

Example (Cont'd)

(Step 3) (Cont'd)

A revised CM Commitment Level for the NDP would be calculated in the same manner as the revised CT Commitment Level for the NDP was calculated, except that such calculations shall use quantities of Equivalent DS1 CMs and the DS1 CM Multiplier. Any prior CM Commitment level established under Section 22.1.7(B) or Section 22.1.7(E) preceding is expressly superseded by the CM Commitment Level established under this Step 3.

(2) Assign the Discount Tiers for the Next Plan Year

Using the combined quantities for the Qualifying Services of the existing ACNAs and the acquired ACNAs in month twelve (12) of the Annual True-Up Period, the Telephone Company will assign the Discount Tiers applicable to the next Plan Year in accordance with Section 22.1.7(F) preceding.

Service availability is limited. See # footnote on Page 22-1.

ACCESS SERVICE

22. Discount Plans (Cont'd)

22.1 National Discount Plan # (Cont'd)

22.1.11 Addition of an ACNA(s) to an Existing NDP (Cont'd)

(B) (Cont'd)

(2) Combine NDPs

- (a) Where an NDP Customer seeks to add one or more ACNA(s) to its NDP in accordance with Section 22.1.11(A)(2) preceding (i.e., such ACNA(s) is/are already included in another NDP), the NDP Customer who wishes to add the ACNA(s) to its NDP has the following options to combine the NDPs involved:

(1) Surviving NDP Option

Combine the NDP for the existing ACNA(s) with the NDP of the added ACNA(s) into a Surviving NDP as set forth in (B)(2)(b) following; or

(2) New NDP Option

Establish a new NDP that combines the existing ACNA(s) and the acquired ACNA(s) as set forth in (B)(2)(c) following.

(b) Surviving NDP Option

This option combines the NDP of the existing ACNAs (Plan A) with the NDP of the acquired ACNAs (Plan B). The Telephone Company will determine whether Plan A or Plan B has the greatest Monthly Charges in the month before the NDPs are combined, and such NDP will be deemed the Surviving NDP. The Surviving NDP shall be augmented to add the acquired ACNAs to the ACNAs of the Surviving NDP.

Service availability is limited. See # footnote on Page 22-1.

ACCESS SERVICE

22. Discount Plans (Cont'd)

22.1 National Discount Plan # (Cont'd)

22.1.11 Addition of an ACNA(s) to an Existing NDP (Cont'd)

(B) (Cont'd)

(2) Combine NDPs (Cont'd)

(b) Surviving NDP Option (Cont'd)

- (1) At the next scheduled Annual True-Up for the Surviving NDP following the effective date of the NDP Customer acquiring the ACNA(s), the Telephone Company will complete Steps (A)(1) through (A)(5) of the Annual True-Up as described in Section 22.1.7(A) preceding for Plan A and separately complete Steps (A)(1) through (A)(5) of the Annual True-Up as described in Section 22.1.7(A) preceding for Plan B. Each Annual True-Up will be conducted as if the NDPs had not been combined. The Telephone Company will conduct the Final True-Up for the non-Surviving NDP using the number of months available at the time the Final True-Up is conducted. The non-Surviving NDP shall be cancelled upon completion of such Final True-Up. Termination liability under Section 22.1.13 following will not apply to such cancellation.
- (2) Once the Annual True-Ups under (B)(2)(b)(1) preceding are complete, and in accordance with Section 22.1.1(C) preceding, the ACNAs, Qualifying Services and Commitment Levels of the non-Surviving NDP will be added to the ACNAs, Qualifying Services and Commitment Levels of the Surviving NDP as follows:
 - (a) If the Surviving NDP used a Standard Commitment Matrix, the Standard Commitment Matrix will continue to apply to the combined plan. If the Surviving NDP used a Premier Commitment Matrix, the Premier Commitment Matrix will continue to apply to the combined plan. If the Surviving NDP used a Deluxe Commitment Matrix, the Deluxe Commitment Matrix will continue to apply to the combined plan; and

Service availability is limited. See # footnote on Page 22-1.

ACCESS SERVICE

22. Discount Plans (Cont'd)

22.1 National Discount Plan # (Cont'd)

22.1.11 Addition of an ACNA(s) to an Existing NDP (Cont'd)

(B) (Cont'd)

(2) Combine NDPs (Cont'd)

(b) Surviving NDP Option (Cont'd)

(2) (Cont'd)

(b) Commitment Levels and Discount Tiers will be adjusted as follows; and

(i) Adjust Commitment Levels

The Telephone Company will adjust Commitment Levels of the Surviving NDP to include the Qualifying Services of the non-Surviving NDP as follows:

(Step 1) Using the table in Section 22.1.4(A)(1) preceding, and the actual quantities of Channel Terminations for the month prior to conducting the Final True-Up for the non-Surviving NDP, determine the number of Equivalent DS1 CTs associated with the Qualifying Service(s) of the acquired ACNA(s) by multiplying (a) the level for the Qualifying Service (e.g., DS3 level); by (b) the DS1 CT multiplier in accordance with the table in Section 22.1.4(A)(1) preceding.

The Telephone Company will determine the number of Equivalent DS1 CMs for the acquired ACNA(s) in the same manner as the number of Equivalent DS1 CTs was developed in the preceding paragraph in accordance with the table in Section 22.1.4(A)(2) preceding.

Service availability is limited. See # footnote on Page 22-1.

ACCESS SERVICE

22. Discount Plans (Cont'd)

22.1 National Discount Plan # (Cont'd)

22.1.11 Addition of an ACNA(s) to an Existing NDP (Cont'd)

(B) (Cont'd)

(2) Combine NDPs (Cont'd)

(b) Surviving NDP Option (Cont'd)

(2) (Cont'd)

(b) (Cont'd)

(i) Adjust Commitment Levels (Cont'd)

(Step 2) The Telephone Company will develop a CT Commitment Level for the acquired ACNA(s) of the non-Surviving NDP by multiplying the result in Step 1 above by eighty-five percent (85%) if the Surviving NDP uses the Standard Commitment Matrix, by ninety percent (90%) if the Surviving NDP uses the Premier Commitment Matrix or by ninety-two percent (92%) if the Surviving NDP uses the Deluxe Commitment Matrix.

The Telephone Company will develop a CM Commitment Level for the acquired ACNA(s) of the non-Surviving NDP in the same manner as the CT Commitment Level was developed in the preceding paragraph.

Service availability is limited. See # footnote on Page 22-1.

ACCESS SERVICE

22. Discount Plans (Cont'd)

22.1 National Discount Plan # (Cont'd)

22.1.11 Addition of an ACNA(s) to an Existing NDP (Cont'd)

(B) (Cont'd)

(2) Combine NDPs (Cont'd)

(b) Surviving NDP Option (Cont'd)

(2) (Cont'd)

(b) (Cont'd)

(i) Adjust Commitment Levels (Cont'd)

(Step 3) The Telephone Company will add the CT Commitment Level for the acquired ACNA(s) determined in Step 2 above to the CT Commitment Level for the remaining portion of the Surviving NDP, the result of which will be the adjusted CT Commitment Level for the remainder of the Term unless otherwise adjusted in this Section 22.1.

The Telephone Company will add the CM Commitment Level for the acquired ACNA(s) determined in Step 2 above to the CM Commitment Level for the remaining portion of the Surviving NDP, the result of which will be the adjusted CM Commitment Level for the remainder of the Term unless otherwise adjusted in this Section 22.1.

(ii) The Plan Year for the Surviving NDP is the next scheduled Plan Year for that NDP prior to combining plans. For example, if the Surviving NDP was in Plan Year 2 prior to the NDPs being combined, the Surviving NDP will be in Plan Year 3 after the NDPs are combined.

Service availability is limited. See # footnote on Page 22-1.

ACCESS SERVICE

22. Discount Plans (Cont'd)

22.1 National Discount Plan # (Cont'd)

22.1.11 Addition of an ACNA(s) to an Existing NDP (Cont'd)

(B) (Cont'd)

(2) Combine NDPs (Cont'd)

(b) Surviving NDP Option (Cont'd)

(2) (Cont'd)

(c) Assign Discount Tiers for the Next Plan Year

Using the combined quantities for the Qualifying Services of the existing ACNAs and the acquired ACNAs in month twelve (12) of the Annual True-Up Period, the Telephone Company will assign the Discount Tier applicable to the Surviving NDP for the next Plan Year in accordance with Section 22.1.7(F) preceding.

Service availability is limited. See # footnote on Page 22-1.

ACCESS SERVICE

22. Discount Plans (Cont'd)

22.1 National Discount Plan # (Cont'd)

22.1.11 Addition of an ACNA(s) to an Existing NDP (Cont'd)

(B) (Cont'd)

(2) Combine NDPs (Cont'd)

(c) New NDP Option

This option combines the NDP of the existing ACNAs (Plan A) with the NDP of the acquired ACNAs (Plan B) into a new NDP (Plan C) that includes the ACNAs of Plan A and Plan B.

- (1) At the first Annual True-Up for either Plan A or Plan B following the effective date of the NDP Customer acquiring the ACNA(s), the Telephone Company will complete Steps (A)(1) through (A)(5) of the Annual True-Up as described in Section 22.1.7(A) preceding for Plan A and separately complete Steps (A)(1) through (A)(5) of the Annual True-Up as described in Section 22.1.7(A) preceding for Plan B. Each Annual True-Up will be conducted as if the NDPs had not been combined. The Telephone Company will conduct a Final True-Up on Plan A, and a separate Final True-Up on Plan B using the number of months available at the time the Final True-Up is conducted. Upon completion of the Final True-Up for each plan, Plan A and Plan B shall both be cancelled without the application of termination liability under Section 22.1.13 following.
- (2) The new NDP shall be established using the quantities of Qualifying Services for the ACNAs of Plan A and Plan B as determined in the Final True-Up for each plan, and shall be established and maintained in accordance with the requirements of this Section 22.1.

Service availability is limited. See # footnote on Page 22-1.

ACCESS SERVICE

22. Discount Plans (Cont'd)

22.1 National Discount Plan # (Cont'd)

22.1.12 Removal of an ACNA(s) as a Result of a Customer Sale

(A) A Customer Sale is the consummation of a sale, divestiture, spin-off, or other transaction which results in the NDP Customer no longer having any (i.e., 0%) control (including any stock or assets) in a Person that is (at the time of the Customer Sale) included within the NDP Customer's NDP. As used in this definition, the term "control" means the possession, directly or indirectly, of the power to direct or cause the direction of the management and policies of a Person, whether through ownership or voting securities, by contract or otherwise.

(1) When an NDP Customer is subject to a Customer Sale, and seeks to remove one or more ACNA(s) from its NDP, the terms of Section (A)(2) following shall apply, and the Telephone Company shall automatically at the next Annual True-Up modify the existing NDP by removing the affected ACNAs and the Qualifying Services associated with the affected ACNA(s). No later than thirty (30) calendar days prior to the Anniversary Date, the NDP Customer must provide a written notice with supporting documentation that describes the Customer Sale, and the ACNAs impacted by such Customer Sale.

If the NDP Customer sells, divests, spins off, or otherwise reduces its control (including any stock or assets) in a Person that is (at the time of the applicable sale transaction) included within the NDP Customer's NDP, but the NDP Customer still retains some control (i.e., greater than 0%) in the affected Person(s), then all of the ACNA(s) of such Person(s) shall continue to be included in the NDP Customer's NDP, in accordance with the terms of Section 22.1.1(C) preceding. As used in this paragraph, the term "control" means the possession, directly or indirectly, of the power to direct or cause the direction of the management and policies of a Person, whether through ownership or voting securities, by contract or otherwise.

Service availability is limited. See # footnote on Page 22-1.

ACCESS SERVICE

22. Discount Plans (Cont'd)

22.1 National Discount Plan # (Cont'd)

22.1.12 Removal of an ACNA(s) as a Result of a Customer Sale (Cont'd)

(A) (Cont'd)

(2) If the NDP Customer has removed an ACNA(s), the Telephone Company shall take the following actions:

(a) At the next Annual True-Up following the effective date of removal of the ACNA(s), the Telephone Company will complete Steps (A)(1) through (A)(5) of the Annual True-Up as described in Section 22.1.7(A) preceding as if the ACNA(s) has not been removed.

(b) Once the Annual True-Up under (2)(a) preceding is complete, the Telephone Company will modify the NDP as follows:

(i) Reduce Commitment Levels

The CT Commitment Level and CM Commitment Level will be reduced by (i) eighty-five percent (85%) of Equivalent DS1 CTs or Equivalent DS1 CMs, as applicable, in month twelve (12) of the Annual True-Up that were associated with the removed ACNA(s) if the NDP uses Standard Commitment Matrix; or (ii) ninety percent (90%) of Equivalent DS1 CTs or Equivalent DS1 CMs, as applicable, in month twelve (12) of the Annual True-Up that were associated with the removed ACNA(s) if the NDP uses Premier Commitment Matrix; or (iii) ninety-two percent (92%) of Equivalent DS1 CTs or Equivalent DS1 CMs, as applicable, in month twelve (12) of the Annual True-Up that were associated with the removed ACNA(s) if the NDP uses Deluxe Commitment Matrix as follows:

(Step 1) Using the table in Section 22.1.4(A)(1) preceding, determine the number of Equivalent DS1 CTs associated with the Qualifying Service(s) of the Customer Sale as calculated in accordance with Section 22.1.4(A) preceding.

The Telephone Company will determine the number of Equivalent DS1 CMs for the removed ACNA(s) in the same manner as the number of Equivalent DS1 CTs was developed in the preceding paragraph.

Service availability is limited. See # footnote on Page 22-1.

ACCESS SERVICE

22. Discount Plans (Cont'd)

22.1 National Discount Plan # (Cont'd)

22.1.12 Removal of an ACNA(s) as a Result of a Customer Sale (Cont'd)

(A) (Cont'd)

(2) (Cont'd)

(b) (Cont'd)

(i) Reduce Commitment Levels (Cont'd)

(Step 2) The Telephone Company will develop a CT Commitment Level for the removed ACNA(s) by multiplying the result in Step 1 above by eighty-five percent (85%) if the NDP uses the Standard Commitment Matrix, by ninety percent (90%) if the NDP uses the Premier Commitment Matrix, or by ninety-two percent (92%) if the NDP uses the Deluxe Commitment Matrix.

The Telephone Company will develop a CM Commitment Level for the removed ACNA(s) of the NDP in the same manner as the CT Commitment Level was developed in the preceding paragraph.

(Step 3) The Telephone Company will subtract the CT Commitment Level for the removed ACNA(s) determined in Step 2 above from the CT Commitment Level for the remaining portion of the NDP, the result of which will be the adjusted CT Commitment Level for the remainder of the Initial Term or Renewal term, as applicable, unless otherwise adjusted in this Section 22.1.

The Telephone Company will subtract the CM Commitment Level for the removed ACNA(s) determined in Step 2 above from the CM Commitment Level of the Initial Term or Renewal term, as applicable, the result of which will be the adjusted CM Commitment Level for the remainder of the Term unless otherwise adjusted in this Section 22.1.

Service availability is limited. See # footnote on Page 22-1.

ACCESS SERVICE

22. Discount Plans (Cont'd)

22.1 National Discount Plan # (Cont'd)

22.1.12 Removal of an ACNA(s) as a Result of a Customer Sale (Cont'd)

(A) (Cont'd)

(2) (Cont'd)

(c) Assign Discount Tiers for the Next Plan Year

Using the reduced quantities for the Qualifying Services of the remaining ACNAs in month twelve (12) of the Annual True-Up Period, the Telephone Company will assign the Discount Tier applicable to the NDP for the next Plan Year in accordance with Section 22.1.7(F) preceding.

(d) Termination Liability under Section 22.1.13 following will not apply for removal of the Qualifying Services from the NDP that are affected by the removal of an ACNA.

22.1.13 Termination Liability

(A) If the NDP is terminated prior to the end of the Initial Term or during the Renewal Term (subject to certain conditions as described in Section 22.1.14 following), termination liability applies to all Qualifying Services.

(B) The termination liability charge applies in addition to any applicable minimum period charges as set forth in Section 22.1.8 preceding.

Service availability is limited. See # footnote on Page 22-1.

ACCESS SERVICE

22. Discount Plans (Cont'd)

22.1 National Discount Plan # (Cont'd)

22.1.13 Termination Liability (Cont'd)

(C) The applicable termination liability during the Initial Term or Renewal Term, as applicable, as set forth below shall be based on the Plan Year in which the NDP Customer terminates the NDP.

Plan Year	Termination Liability
1	100% of the monthly recurring charges for all Discounted Rate Elements for the remainder of Plan Year 1 and 50% of the monthly charges for the remaining 4 years.
2	50% of the monthly recurring charges for all Discounted Rate Elements for the remainder of Plan Year 2 and 50% of the monthly charges for the remaining 3 years.
3	25% of the monthly recurring charges for all Discounted Rate Elements for the remainder of Plan Year 3 and 25% of the monthly charges for the remaining 2 years.
4	15% of the monthly recurring charges for all Discounted Rate Elements for the remainder of Plan Year 4 and 15% of the monthly charges for the remaining year. If the NDP Customer has selected the Renewal Benefit Option as described in Section 22.1.14(C) following, termination liability during Plan Year 4 does not apply after month 42 of the Renewal Term.
5	10% of the monthly recurring charges for all Discounted Rate Elements for the remainder of Plan Year 5. If the NDP Customer has selected the Renewal Benefit Option as described in Section 22.1.14(C) following, termination liability during Plan Year 5 does not apply during the Renewal Term.

Service availability is limited. See # footnote on Page 22-1.

ACCESS SERVICE

22. Discount Plans (Cont'd)

22.1 National Discount Plan # (Cont'd)

22.1.14 Renewal and Termination of NDP

(A) Description

No later than sixty (60) calendar days prior to expiration of the Initial Term or Renewal Term, as applicable, of the NDP, the NDP Customer must provide the Telephone Company with written notice of its election of one of the following options.

- (1) Renew its NDP for a 5-year Renewal Term as described in this Section 22.1.14 including providing written election of its subscription to the Renewal Benefit Option as set forth in Section 22.1.14(C) following; or
- (2) subscribe the Qualifying Services of the expiring NDP to any then effective discount plan, term plan or Contract Tariff Option for which the NDP Customer is eligible; or
- (3) continue with service on a month-to-month basis without any discount or term plan; or
- (4) discontinue service for all Qualifying Services without the application of termination liability as set forth in Section 22.1.13 preceding.

Service availability is limited. See # footnote on Page 22-1.

ACCESS SERVICE

22. Discount Plans (Cont'd)

22.1 National Discount Plan # (Cont'd)

22.1.14 Renewal and Termination of NDP (Cont'd)

(B) Renewal

The NDP Customer's election to renew its NDP for another Renewal Term under Section 22.1.14(A)(1) preceding must be provided in writing and must be received by the Telephone Company no later than 60 calendar days prior to expiration of the Term. If the NDP Customer does not provide the Telephone Company with written notice (including providing timely notice) of its election under Section 22.1.14(A) preceding, and subject to the following requirements, the expiring NDP shall automatically renew for a 5-year Renewal Term at the end of the Initial Term or Renewal Term, as applicable.

- (1) The Telephone Company will conduct the Annual True-Up for Plan Year 5 in accordance with Section 22.1.7 preceding (Final True-Up), except that such Final True-Up shall not include the following:
 - (a) The Commitment Buy-Up option as set forth in Section 22.1.7(E) preceding; and
 - (b) The Telephone Company will not assign Discount Tiers for the expiring NDP since the NDP has just completed its last Plan Year of the Initial Term or Renewal Term, as applicable; and
 - (c) Subject to Section 22.1.14(C) following, where the NDP Customer provides timely notice of its election under Section 22.1.14(A) preceding, the NDP Customer may change the Commitment Matrix to any available Commitment Matrix option.

Service availability is limited. See # footnote on Page 22-1.

ACCESS SERVICE

22. Discount Plans (Cont'd)

22.1 National Discount Plan # (Cont'd)

22.1.14 Renewal and Termination of NDP (Cont'd)

(B) Renewal (Cont'd)

(2) The Telephone Company shall establish the renewed NDP using the quantities of Qualifying Services for all of the NDP Customer's ACNAs (including any ACNAs associated with any Person(s) that are included in the NDP Customer's NDP, as determined in Section 22.1.1(C) preceding). The renewed NDP shall be established and maintained in accordance with the requirements of this Section 22.1 and shall be subject to the following conditions:

(a) A Renewal Term of five (5) years; and

(b) All Qualifying Services that the NDP Customer subscribed to in month twelve (12) of Plan Year 5 of the expiring Initial Term or a Renewal Term, as applicable, must be included in the Renewed NDP; and

(c) The NDP Customer must specify a Commitment Matrix Option for the Renewal Term from those offered under Section 22.1.4(C) preceding, except where the NDP Customer selects the Renewal Benefit Option under Section 22.1.14(C) following, in which case the NDP Customer must select either the Premier Commitment Matrix or the Deluxe Commitment Matrix; and

Service availability is limited. See # footnote on Page 22-1.

ACCESS SERVICE

22. Discount Plans (Cont'd)

22.1 National Discount Plan # (Cont'd)

22.1.14 Renewal and Termination of NDP (Cont'd)

(B) Renewal (Cont'd)

(2) (Cont'd)

- (d) The Telephone Company will develop the CT Commitment Level for the Renewal Term using the actual number of Equivalent DS1 CTs for Qualifying Services that were subscribed to in month twelve (12) of Plan Year 5 of the expiring Initial Term or the Renewal Term, as applicable. If the Renewal Benefit Option under Section 22.1.14(C) following is selected, the CT Commitment Level of the new NDP must be equal to or greater than the CT Commitment Level for the expiring NDP. The calculation shall be performed in accordance with Section 22.1.4 preceding; and
- (e) The Telephone Company will develop the CM Commitment Level for the Renewal Term using the actual number of Equivalent DS1 CMs for Qualifying Services that were subscribed to in month twelve (12) of Plan Year 5 of the expiring Initial Term or the Renewal Term, as applicable. If the Renewal Benefit Option under Section 22.1.14(C) following is selected, the CM Commitment Level of the new NDP must be equal to or greater than the CM Commitment Level for the expiring NDP. The calculation shall be performed in accordance with Section 22.1.4 preceding; and
- (f) New Discount Tiers will be assigned for the renewed NDP using the actual quantity of Equivalent DS1 CTs or actual quantity of Equivalent DS1 CMs, as applicable, that were subscribed to in month twelve (12) of Plan Year 5 of the expiring Plan; and
- (g) The renewed NDP shall begin in Plan Year 1 but shall continue to receive the discounts associated with Plan Year 5 as set forth in Section 22.1.5(B) preceding.

Service availability is limited. See # footnote on Page 22-1.

ACCESS SERVICE

22. Discount Plans (Cont'd)

22.1 National Discount Plan # (Cont'd)

22.1.14 Renewal and Termination of NDP (Cont'd)

(C) Renewal Benefit Option

- (1) If the NDP Customer elects the Renewal Benefit Option, and makes such election in a timely manner as set forth in Section 22.1.14(A) preceding, the expiring NDP shall be renewed at the end of the expiring Initial Term or Renewal Term, as applicable, in accordance with the requirements of (B)(2) preceding. If the NDP Customer does not provide timely notice of its election to renew under Section 22.1.14 preceding, the NDP Customer is not eligible for the Renewal Benefit Option.
- (2) When the Renewal Benefit Option is selected, termination liability under Section 22.1.13 preceding is only applicable for the first forty-two (42) months of the Renewal Term. Termination Liability is not applicable in month forty-three (43) through month sixty (60) of the Renewal Term (Renewal Benefit Period).

For example, assume the NDP Customer renews its NDP on November 1, 2012. In this case, the Renewal Term begins November 1, 2012 and ends October 31, 2017. If the NDP Customer were to terminate its NDP at any time after May 1, 2016 (i.e., during the Renewal Benefit Period which is after month forty-two (42) of the Renewal Term), termination liability as set forth in Section 22.1.13 preceding is not applicable.

For a second example, assume the NDP Customer renews its NDP on November 1, 2012. In this case, the Renewal Term begins November 1, 2012 and ends October 31, 2017. If the NDP Customer were to cancel its NDP at any time prior to May 1, 2016 (i.e., during the first forty-two (42) months of the Renewal Term), termination liability as set forth in Section 22.1.13 preceding applies.

Service availability is limited. See # footnote on Page 22-1.

ACCESS SERVICE

22. Discount Plans (Cont'd)

22.1 National Discount Plan # (Cont'd)

22.1.14 Renewal and Termination of NDP (Cont'd)

(D) Cancellation or Termination During the Renewal Term

- (1) When the NDP is cancelled or terminated during the Renewal Term, a Final True-Up will be conducted in order to determine any applicable Shortfall Penalty or Discount Tier Adjustments. The Shortfall Penalty and Discount Tier Adjustments will be calculated as specified in Section 22.1.7(C) and (D) preceding, respectively, on a pro-rated basis, for the number of months elapsed since the last Annual True-Up.
- (2) If the NDP is cancelled or terminated during the Renewal Benefit Period as defined in Section 22.1.14(C)(2) preceding (i.e., during the period that begins with month 43 and ends with month 60 of the Renewal Term), the NDP Customer will be treated as if it had completed the full Renewal Term of five (5) years. At the NDP Customer's option, and at any time between month 43 and month 60 of the Renewal Term, the NDP Customer may once again renew its NDP. The NDP Customer may elect the Renewal Benefit Option for any subsequent Renewal Term.
- (3) Except as otherwise specified in this Section 22.1.14, all terms and conditions of the NDP as set forth in this Section 22.1 shall apply.

Service availability is limited. See # footnote on Page 22-1.

ACCESS SERVICE

23. Tariffed Service Components

The Tariffed Service Components offered in this Section 23 are for the exclusive use of customers for connecting to the interstate services provided by the Telephone Company as described in more detail herein.

23.1 Integrated Optical Service Riders

23.1.1 General

- (A) Telephone Company provided integrated optical service, which is provided where technically and operationally feasible as determined by the Telephone Company, provides a customer with a single network platform that is capable of converging SONET, Dense Wave Division Multiplexing, and Ethernet technologies.
- (B) An Integrated Optical Service Rider is a service component provided under tariff that allows a lower level signal to be transported only between two points (nodes) on a Telephone Company provided integrated optical service.
- (C) Integrated Optical Service Riders are provided in the following protocols:
 - (1) DS1 Special Access – for transmission of isochronous serial data at a rate of 1.544 Mbps.
 - (2) DS3 Special Access – for transmission of isochronous serial data at a rate of 44.736 Mbps.
- (D) Integrated Optical Service Riders are only available on a protected basis. A protected rider allows for a single signal from the customer to be duplicated and sent over separate diverse routes (working and protect).

23.1.2 Deployment and Availability

Integrated Optical Service Riders may only be added to an in-service Telephone Company provided integrated optical service. Integrated Optical Service Riders are provided based on negotiated intervals.

ACCESS SERVICE

23. Tariffed Service Components (Cont'd)

23.1 Integrated Optical Service Riders (Cont'd)

23.1.3 Connection to Other Services

- (A) A High Capacity Special Access DS1/DS3 service may be connected to an in-service Telephone Company provided integrated optical service to be originated or terminated to an integrated optical service customer designated premises node via an Integrated Optical Service DS1/DS3 Rider.
- (B) The High Capacity Special Access Service must be ordered with the same length Commitment Period as the Integrated Optical Service Rider.
- (C) For purposes of administering the regulations and rates contained in this Guide, the portion of the High Capacity Special Access Service which is delivered over the Telephone Company provided integrated optical service is considered to be a High Capacity Special Access service, except as follows: Rates and charges for the High Capacity Special Access service are not applicable to the portion of the service which is delivered over the Telephone Company provided integrated optical service. Rates for the Integrated Optical Service Rider are applicable to the portion of the service which is delivered over the Telephone Company provided integrated optical service.

23.1.4 Responsibility of the Customer

All Integrated Optical Service Rider signals generated by CPE and delivered to the Telephone Company for multiplexing on to an integrated optical service must meet industry standards and specifications for the underlying protocol. The customer is responsible to perform any error detection and error correction of the data generated by its equipment. The Telephone Company assumes no responsibility for the quality of the signal generated by the customer or any CPE and will deliver the signal to the receiving location in the same format and condition as generated by the customer.

ACCESS SERVICE

23. Tariffed Service Components (Cont'd)

23.1 Integrated Optical Service Riders (Cont'd)

23.1.5 Conversions

- (A) Customers who wish to convert both points of termination of an existing High Capacity Special Access Service to an Integrated Optical Service Rider may do so without termination liability as long as the capacity of the Integrated Optical Service Rider purchased by the customer is equal to or greater than the capacity of the converted High Capacity Special Access Service.
- (B) Customers who wish to convert one point of termination of an existing High Capacity Special Access Service to an Integrated Optical Service Rider, as specified in Section 23.1.3 preceding, may do so without termination liability.

23.1.6 Application of Rates

- (A) For each Integrated Optical Service Rider, monthly recurring rates apply at the ingress and egress locations (Appearances) on the integrated optical service. Two Appearances (one for ingress and one for egress) apply for an Integrated Optical Service Rider provided in a point-to-point (node-to-node) configuration.
- (B) When a High Capacity Special Access Service is ordered to connect to a Telephone Company provided integrated optical service as specified in Section 23.1.3 preceding, the Integrated Optical Service Rider rates will be billed to the customer of record for the associated High Capacity Special Access service.

23.1.7 Term Plans

Integrated Optical Service Riders are available for term plan lengths of one (1) year, two (2) years, three (3) years, five (5) years, or seven (7) years (Commitment Periods).

ACCESS SERVICE

23. Tariffed Service Components (Cont'd)

23.1 Integrated Optical Service Riders (Cont'd)

23.1.8 Expiration of Commitment Period

Upon expiration of any Commitment Period, the Telephone Company will continue to provide Integrated Optical Service Riders on a month-to-month basis, under the prevailing rates of the current term plan, until the customer cancels service or requests a new term plan.

23.1.9 Termination Liability

(A) Integrated Optical Service Riders are subject to termination liability if service is disconnected prior to the end of the Commitment Period. Termination liability is calculated as follows:

- (1) If the disconnection occurs during the first year of the Commitment Period, the Minimum Period obligation specified in Section 23.1.10 following applies for the unexpired portion of the first year. Termination liability is calculated at one hundred percent (100%) of the monthly recurring rates for the second year and twenty-five percent (25%) of the monthly recurring rates for the 25th month through the remainder of the Commitment Period, as applicable.
- (2) If the disconnection occurs during the second year of the Commitment Period, termination liability is calculated at one hundred percent (100%) of the monthly recurring rates for the unexpired portion of the second year and twenty-five percent (25%) of the monthly recurring rates for the 25th month through the remainder of the Commitment Period, as applicable.
- (3) If the disconnection occurs after the first two (2) years of the Commitment Period, termination liability is calculated at twenty-five (25%) of the monthly recurring rates from the date of disconnection through the remainder of the Commitment Period.

ACCESS SERVICE

23. Tariffed Service Components (Cont'd)

23.1 Integrated Optical Service Riders (Cont'd)

23.1.9 Termination Liability (Cont'd)

(B) Termination liability will not apply in the following situations:

(1) An Integrated Optical Service Rider is upgraded to a higher capacity Integrated Optical Service Rider (i.e., DS1 to DS3), and the following conditions are met:

(a) The new Integrated Optical Service Rider has an equal or longer Commitment Period than the existing Integrated Optical Service Rider; and

(b) All of the locations of the existing Integrated Optical Service Rider and new Integrated Optical Service Rider are the same.

The Customer remains responsible for satisfying any outstanding Minimum Period obligations.

(2) The customer cancels its term plan in order to establish a new term plan with a Commitment Period that is equal to, or longer than, the term plan being cancelled.

23.1.10 Minimum Period

(A) If an Integrated Optical Service Rider is disconnected during the Minimum Period, the customer shall pay to the Telephone Company one hundred percent (100%) of the monthly recurring rates from the date of disconnection through the end of the Minimum Period.

(B) Integrated Optical Service Riders are subject to a one (1) year Minimum Period.

ACCESS SERVICE

23. Tariffed Service Components (Cont'd)

23.1 Integrated Optical Service Riders (Cont'd)

23.1.11 Rates and Charges

Integrated Optical Service Riders

Protected
- Per appearance

	<u>Nonrecurring Charge</u>	<u>Monthly Recurring Rates</u>
DS1		
1-Year Term	\$0.00	\$75.00
2-Year Term	\$0.00	\$75.00
3-Year Term	\$0.00	\$75.00
5-Year Term	\$0.00	\$75.00
7-Year Term	\$0.00	\$75.00
DS3		
1-Year Term	\$0.00	\$150.00
2-Year Term	\$0.00	\$150.00
3-Year Term	\$0.00	\$150.00
5-Year Term	\$0.00	\$150.00
7-Year Term	\$0.00	\$150.00

ACCESS SERVICE

23. Tariffed Service Components (Cont'd)

23.2 Point To Point SONET Service Facilities

23.2.1 General

Telephone Company provided point to point SONET service is provided where technically and operationally feasible as determined by the Telephone Company and provides a customer with SONET based broadband access transport over the Telephone Company's shared SONET network. The customer has the option to order the service with multiplexing capability from which lesser capacity channels can be derived via riders.

(A) DS3 Transmux Facility

The customer has the option to order a DS3 Transmux Facility which performs a DS3 to DS1 conversion. The DS3 Transmux Facility allows a single DS3 Transmux Facility to be associated with up to twenty-eight (28) Special Access DS1 riders.

- (1) The DS3 Transmux Facility aggregates the facilities associated with the DS1 rider circuits as part of a higher level DS3 handoff that is dropped from multiplexed point to point SONET service.
- (2) The DS3 Transmux Facility provides a two-point channelized facility between a customer designated location and the SONET Premises Node at that location.

23.2.2 Deployment and Availability

The point to point SONET service DS3 Transmux Facility is provided with the same service interval applicable to High Capacity Digital DS3 Service.

23.2.3 Connection to Other Services

DS1 riders may be connected to a DS3 Transmux Facility via the multiplexed point to point SONET service facility. The customer must specify the connecting facility assignment (CFA) for both the DS3 Transmux Facility and the multiplexed point to point SONET service facility.

ACCESS SERVICE

23. Tariffed Service Components (Cont'd)

23.2 Point To Point SONET Service Facilities (Cont'd)

23.2.4 Application of Rates and Charges

- (A) DS1 Rider rates and charges apply for each DS1 rider circuit provided over the DS3 Transmux Facility.
- (B) Change From DS3 Transmux Facility to a DS3 Rider or Vice Versa
 - (!) A change from a DS3 Transmux Facility to a DS3 rider will be treated as a discontinuance of the DS3 Transmux Facility and all of its associated riders and installation of a new DS3 rider. All associated nonrecurring charges will apply for the new DS3 rider.
 - (2) A change from a DS3 rider to a DS3 Transmux Facility will be treated as a discontinuance of the DS3 rider and installation of a new DS3 Transmux Facility.

23.2.5 Term Plans

DS1 riders provided over a DS3 Transmux Facility are provided on a month-to-month basis.

23.2.6 Minimum Period

There is no minimum period for point to point SONET service.